

# ALL STAR SERIES 2010

## SUPPLEMENTARY REGULATIONS

### Authority

These meetings will be held under the International Sporting Code of the FIA, the General Karting Regulations of the AKA & any further addendums & bulletins to the regulations.

<b>Name of Event</b>	<b>ALL STAR SERIES ROUND 1</b> <b>13<sup>th</sup> &amp; 14<sup>th</sup> March 2010</b>
<b>Location of Event</b>	Go Kart Club Of Victoria –Port Melbourne Victoria
<b>Promoters</b>	Geelong Kart Racing Club, Go Kart Club of Victoria, Oakleigh Go Kart Racing Club & Eastern Lions Kart Club
<b>Track Direction</b>	<b>Anticlockwise</b>
<b>Permit Number</b>	VKA040310
<b>Stewards</b>	Bob Vagg, Arthur Etherington ,Fran Kelsall, Sylvia Stania
<b>Clerk of Course</b>	Graham Monds, Paul Stania
<b>Race Secretary</b>	Luke Burt
<b>Starter/s</b>	Luke Burt
<b>Lap Scorers</b>	Verlie Bryer Stella Pringle Margaret Uhorn Denise Wall
<b>Judges of Fact</b>	AKA Rule 4.17
<b>AMB LAP SCORING</b>	Doug Wilson
<b>Scrutineers</b>	Gary Haythorpe
<b>Grid Marshall's</b>	Rosemary Grace Anita Lowerson Susan McDougall
<b>Scales Marshall's</b>	Janette Monds
<b>Flag Marshall's</b>	GKCV Members
<b>Engine Measurers</b>	Gary Haythorpe
<b>State Tech Advisor</b>	Harold Arnett
<b>Commentator.</b>	

**Entry Fee** (incl. GST) \$90 per class entry \$80 per 2<sup>nd</sup> Entry

**Entries To** Luke Burt GKCV Race Secretary 7 Chlorinda Rd. Tarneit 3029

### **Mail Entry Only**

AKA Entry Form complete with payment Cheque, Postal Note or EFT only.

**(Sorry No Credit Cards). NO Phone or Fax ENTRIES WILL BE ACCEPTED**

**EFT** Go Kart Club of Victoria Commonwealth Bank BSB 063181 ACC.NO.1012 8937

Reference Driver name & Class

**Entries & Class Close** Wednesday 10<sup>th</sup> March for Class formation and to be included in race program.  
**Entries close 4 pm Friday 12 th March 2010**

**Kart no's** Kart/Racing Number - Drivers are requested to use their allocated class Number as their kart number and to use the same number throughout the All Star Series. In subsequent All Star Series rounds, kart number preference will be given to those drivers having competed at previous All Star Series round(s).

### **Classes**

1. Midgets	2. Rookies	3. Junior Nat.Light	4. Junior Nat.Heavy
5. Junior Clubman	6. Clubman Light	7. Clubman Heavy	8. Clubman 0'40's
9. F100	10. Leopard Light	11. Rotax Light	12. Rotax Heavy
13. Leopard Heavy	14. Junior Max	15. Tag 125 R	

### **MINIMUM OF TEN (10) ENTRANTS TO FACE THE STARTER OR CLASS MAY BE WITHDRAWN**

CLASSES NOT FORMED AT ROUND 1 WILL NOT BE OFFERED AT SUBSEQUENT ROUNDS (at discretion of organizing club)

### **Points System**

401 less 10%

### **POINTS FOR ALL CLASSES & ALL HEATS WILL TALLY FOR SERIES**

**Non finishers awarded points based on position at last lap completed lap,**

**Non Starters will receive zero point.**

**Final Only Counts**

**AMB TRANX 160 transponders will be used throughout the event for all Lap scoring of heats , pre final and final.. Personal transponders may be used. Please include your AMB seven digit number on the AKA scrutineering form and confirm this number at entry confirmation**

**NOTE: Transponders are available for use (until July 2010)**

### **METHOD OF RACING:**

#### **Under Subscribed Classes**

**Heats 1 & 2 – 10 Laps, Pre-final - 14 Laps, Final - 16 Laps.**

Pre-drawn grid for 1<sup>st</sup> Heat. Reverse grid for 2<sup>nd</sup> Heat

Combined points from heats determines grid position of pre final

Finishing order of pre final determines grid position for the final

**Final only counts on the day.**

**Over-subscribed classes:**

**Heats 1 & 2 – 10 Laps, Pre-final - 14 Laps, Final - 16 Laps**

Class will split into two groups of even quantity groups A & B  
Pre-drawn grid for 1<sup>st</sup> Heat. Reverse grid for 2<sup>nd</sup> Heat for the two groups

- a. Heat 1 ( Group A)
- b. Heat 1 ( Group B)
- c. Heat 2 ( Group A)
- d. Heat 2 ( Group B)

Only the **Top thirty six ( 36 )** placed competitors to progress to finals.  
Grid positions for Pre- Final are based on the points gained during the 2 Heats.  
Driver with the highest points to grid 1, next to grid 2 and so on up to track capacity, compete in the Pre Final. Drivers with equal points up to track capacity, grid positions will be determined by highest points finishing position.

Finishing order of pre final determines grid position for the final

**Final only counts on the day.**

**Prizes**

**Trophies** awarded to **1<sup>st</sup>, 2<sup>nd</sup> and 3<sup>rd</sup>** placegetters.

**ALL STAR SERIES Prizes for a Yamaha Engine & Set of Tyres for each class will be a random draw for all drivers ( must complete all four rounds to be eligible to go in to the draw) Each class must have 12 starters at each round. Trophies awarded to 1<sup>st</sup> 2<sup>nd</sup> & 3<sup>rd</sup> placegetters at completion of the series at the VKA Presentation Night 11<sup>th</sup> December 2010 and venue TBA**

**Blue and Red Double Diagonal** flag **will** be used during this meeting.

**Weights/Fuel/Tyres** As per 2010 AKA Manual and Amendments.

**Number of Starters** Maximum number of karts per each event is 36.

**Track Closure/Track will be closed to all entrants for practice from Monday to Thursday inclusive. Gates will be open on Friday for Unofficial Practise & Pit set up.**

**Time Table**

<b>Friday 12<sup>th</sup> March</b>		<b>Saturday 13<sup>th</sup> March</b>		<b>Sunday 14<sup>th</sup> March</b>	
Unofficial Practice	9.00am – 6.00pm	Gates Open	6.30am	Gates Open	6.30am
Entry Confirmation	4.00pm – 6.00pm	Entry Confirmation	7.00am - 8.00am	Carb Practice Session	7.30am
Track/Grid Closed	6.00pm	Carb Practice Session	7.30am	Drivers' Briefing (On Grid)	Follows Practice
Security on site overnight Fri and Sat	6.30pm	Drivers' Briefing (On Grid)	Follows Practice	Racing	Follows driver briefing.
		Racing	Immediately after Drivers briefing	Presentation Follows Racing	

**Scrutineering**

- ▶ Cylinder head and exhaust sealing nuts are required.
- ▶ Correctly fitted Transponder Holder to suit AMB TranX 160 timing system is required – Transponder holders will be available on the day at a cost of \$10 each.

# Fitting instructions for AMB Transponder bracket.

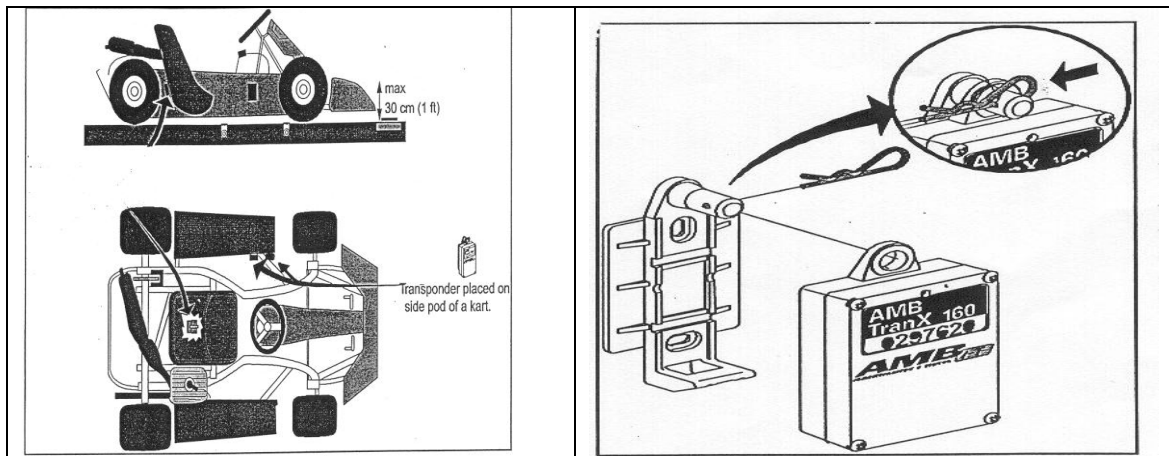

## **Pitting / Passes / Sealing Tags / Security / Canteen**

Pit passes and sealing tags will be issued at Confirmation of Entry.

Pitting from trailers or vehicles will be limited and restricted to designated areas only.

**Security will be provided Friday and Saturday evenings.**

**Canteen will be open** Friday, Saturday & Sunday with breakfast available on Saturday & Sunday.

## **PLEASE NOTE:**

- **Parking of motor vehicles is not permitted in the designated pit area.**
- **Smoking or welding is not allowed in the designated pit area.**
- **Dumping of Fuel is only permitted in drums provided.**
- **Animals are not allowed**
- **No riding of scooters or bikes permitted.**
- **Camping is not permitted.**
- **Hire Marquees are not to be erected without the knowledge & approval of the GKC**
- **It is a condition of entry to display sponsor decals on karts as directed by the promoter.**
- **Lost or damaged transponders will be the responsibility of the driver and / or entrant and will be charged by the Geelong Kart Club for the cost of repair and / or replacement**

***These Supplementary Regulations must be read in conjunction with the 2010 AKA Manual and published Amendments..***

***The promoters reserve the right at their sole discretion to refuse entry, or alter, abandon, combine, postpone or cancel any event as per the 2010 AKA Manual and published Amendments.***

Further information is available from the following Race Secretaries:-

### **Geelong**

Dominic Albanese  
Geelong Kart Club  
P. O Box 950  
Geelong Vic 3220  
03 5255 1603

### **Go Kart Club of Victoria**

Luke Burt  
Go Kart Club of Victoria  
1 Cook Street  
Port Melbourne 3207  
Mob.0411 651 337

### **E.L.KC**

Wayne Cubbin  
Eastern Lions Club  
PO Box 49  
Nagambie Vic. 3608  
ph.03 5794 2285

### **Oakleigh**

Melina Heraud  
Oakleigh Kart Club  
PO Box 215  
Braeside Vic.3195