



2011 KARTING MANUAL



2011 National Competition Rules
AUSTRALIAN KARTING ASSOCIATION INCORPORATED



**49TH AUSTRALIAN
NATIONAL SPRINT KART
CHAMPIONSHIPS
EASTER 2011
PERTH WA**

**Cockburn International Raceway
April 22nd, 23rd & 24th**



FOR MORE INFORMATION, CONTACT US AT ONE OF THESE KART CLUBS OR VISIT OUR WEBSITE:
EMAIL: admin@ingolokartclub.com.au OR VISIT: www.ingolokartclub.com.au

Proudly supported by The Australian Karting Association in cooperation with the New South Wales Kart Club & the Australian Karting Association WA.



AUSTRALIAN KARTING ASSOCIATION INCORPORATED

MANUAL

44th Edition

Previous editions have been published annually since 1966.

This Manual is published with the authority of the National Karting Council, the executive body of the AUSTRALIAN KARTING ASSOCIATION INC.

All red writing indicates either a new rule or one that has been amended from the previous edition of the AKA Manual.
Any reference to gender that may appear in this manual should be referred to as he/she or his/her.

CONTENTS

| | |
|---|--|
| Life Members..... | |
| Past National Executive Members..... | |
| AKA Executive | |
| AKA National Coordinators and Officials | |
| NKC State Delegates | |
| AKA State Secretaries | |
| AKA State Presidents | |
| AKA Judicial Contacts..... | |
| National Committees | |
| National Championship Results -2010 | |

RULES OF THE AKA

Administrative Procedures

Definitions

| | |
|------------|--|
| Chapter 1. | General Standing Regulations..... |
| 2. | Fees..... |
| 3. | Insurance..... |
| 4. | Officials and Duties |
| 5. | General Offences..... |
| 6. | Penalties |
| 7. | Complaints |
| 8. | Appeals |
| 9. | Tribunal Procedure |
| 10. | Australian Motor Sport Appeal Court..... |

SPRINT RACING REGULATIONS

| | |
|-------------|--|
| Chapter 11. | Standard Supplementary Regulations Format..... |
| 12. | Scrutineering and Technical Inspection..... |
| 13. | Competition Driver Licences |
| 14. | Protective Clothing..... |
| 15. | Flag Signals |
| 16. | National Competition Rules..... |
| 17. | Circuit Safety Regulations..... |
| 18. | Event Race Formats..... |
| 19. | Closed State Titles / Australian Master Games..... |
| 20. | National Events..... |

HOMOLOGATION OF ENGINES AND AFTERMARKET PARTS

| | |
|-------------|---|
| Chapter 21. | AKA Equipment Registration & Homologation Procedures..... |
| 22. | Fuel/Fuel Testing |
| 23. | Tyres..... |
| 24. | Noise Control..... |
| 25. | Australian Kart Formula..... |
| 26. | Generic Compliance Checks |

AKA CLASSES

| | |
|-------------|---------------|
| Chapter 27. | Midgets |
| 28. | Rookies..... |

| | |
|-----|-----------------------------------|
| 29. | Junior Nationals |
| 30. | Junior Clubman |
| 31. | Formula Junior Max |
| 32. | Junior Performance |
| 33. | Senior National |
| 34. | Clubman 100cc |
| 35. | Yamaha 100 Tag |
| 36. | Sportsman Class |
| 37. | Restricted 125 |
| 38. | Formula Rotax 125 |
| 39. | Parilla Leopard |
| 40. | Tag 125 |
| 41. | Formula 100 |
| 42. | Open Performance |
| 43. | Australia Based CIK Classes |
| 44. | Speedway |
| 45. | Dirt Track |
| 46. | Endurance Karting |
| 47. | Vintage Karting |

DRIVERS INDEX

| |
|--------------------------------|
| AKA 2011 Events Calendar |
|--------------------------------|

AUSTRALIAN KARTING ASSOCIATION INC

LIFE MEMBERS

| NAME | APPOINTED | STATE |
|-------------------|------------|-------------------|
| • Mr J Duckworth | 27.07.1968 | VICTORIA |
| Mr J Harrison | 08.08.1970 | NEW SOUTH WALES |
| Dr R Phillips | 13.08.1972 | VICTORIA |
| Mr A Gore | 31.08.1974 | VICTORIA |
| • Mrs J Hodgetts | 31.08.1974 | SOUTH AUSTRALIA |
| Mr L Power | 31.07.1976 | WESTERN AUSTRALIA |
| Mr N Osborn | 07.08.1977 | QUEENSLAND |
| • Mr N Hunter | 09.08.1980 | VICTORIA |
| • Mr D Liddle | 08.08.1982 | SOUTH AUSTRALIA |
| • Mr F Swann | 06.08.1983 | WESTERN AUSTRALIA |
| Mr P Ward | 03.08.1984 | VICTORIA |
| Mr G Jacobs | 02.08.1986 | TASMANIA |
| Mr K Mitchell | 02.08.1987 | NEW SOUTH WALES |
| Mr W MacGregor | 04.08.1991 | SOUTH AUSTRALIA |
| Mr D Singline | 06.08.1993 | TASMANIA |
| Mr R Edyvean | 07.09.2000 | QUEENSLAND |
| Mr B Campbell | 07.09.2000 | TASMANIA |
| • Mr K Jenner | 07.09.2002 | SOUTH AUSTRALIA |
| Mr Harold Arnett | 27.08.2004 | VICTORIA |
| Mr David Clarke | 27.08.2004 | WESTERN AUSTRALIA |
| Mr Craig Denton | 27.08.2004 | SOUTH AUSTRALIA |
| Mr Gary Light | 29.10.2005 | WESTERN AUSTRALIA |
| • Mr Brian Farley | 26.08.2006 | NEW SOUTH WALES |
| Mr Alf Capri | 26.08.2007 | QUEENSLAND |
| Mrs Maureen Capri | 26.08.2007 | QUEENSLAND |
| Mrs Pam Arnett | 22.08.2008 | VICTORIA |
| Mr Max Laybutt | 21.08.2010 | NEW SOUTH WALES |
| • passed away | | |

THE AUSTRALIAN KARTING ASSOCIATION INC

PAST NATIONAL EXECUTIVE MEMBERS

CHAIRMAN

| | | |
|--------------|---------------------|-----------------|
| G. Carlsen | 17.08.63 - 28.10.63 | New South Wales |
| D. Ingersole | 28.10.63 - 29.03.64 | Victoria |
| • J. Self | 29.03.64 - 31.10.64 | South Australia |
| G. Carlsen | 31.10.64 - 10.07.65 | New South Wales |

CHIEF EXECUTIVE OFFICER

| | | |
|--------------|---------------------|-----------------|
| R. Edyvean | 19.05.97 - 31.12.00 | Queensland |
| Colin Wilson | 01.01.01 - 06.02.03 | New South Wales |

NATIONAL PRESIDENTS

| | | |
|---------------|---------------------|-------------------|
| D. Ingersole | 19.07.65 - 26.08.67 | Victoria |
| I. Cowin | 26.08.67 - 27.07.68 | Victoria |
| J. Harrison | 27.07.68 - 08.08.70 | New South Wales |
| • L. Atherton | 12.08.72 | Queensland |
| L. Power | 20.09.73 - 08.08.80 | Western Australia |
| N. Osborn | 08.08.80 - 08.08.82 | Queensland |
| G. Jacobs | 08.08.82 - 01.08.86 | Tasmania |
| P. Ward | 01.08.86 - 07.08.96 | Victoria |
| R. Edyvean | 07.08.96 - 17.05.97 | Queensland |
| • K. Jenner | 07.08.97 - 18.11.02 | South Australia |
| D. Wells | 21.02.03 - 29.10.05 | Tasmania |
| R. Erdmann | 29.10.05 - 21.08.09 | New South Wales |
| T. Crane | 21.08.09 - 20.08.10 | Victoria |
| S. Whiting | 20.08.10 - | New South Wales |

NATIONAL VICE PRESIDENTS

| | | |
|---------------|-------------|-------------------|
| I. Cowin | 1966 - 1967 | Victoria |
| H. Rhodes | 1967 - 1968 | Victoria |
| R. Phillips | 1968 - 1970 | Victoria |
| J. Hooker | 1970 - 1971 | Western Australia |
| • L. Atherton | 1971 - 1972 | Queensland |
| L. Power | 1972 - 1973 | Western Australia |

| | | | |
|---|-------------|-------------|-----------------|
| | M. Paton | 1974 - 1976 | New South Wales |
| • | N. Hunter | 1976 - 1980 | Victoria |
| | P. Ward | 1980 - 1986 | Victoria |
| | D. Singline | 1986 - 1993 | Tasmania |
| | R Edyvean | 1993 - 1996 | Queensland |
| | B. Campbell | 1996 - 2000 | Tasmania |
| | R van Doorn | 2001 - 2002 | Queensland |
| | D. Wells | 2002 - 2003 | Tasmania |
| | A. Adams | 2003 - 2004 | Queensland |
| • | B. Farley | 2004 - 2005 | New South Wales |
| | I. Mooney | 2005 - 2007 | South Australia |
| | S. Whiting | 2007 - 2010 | New South Wales |
| | D. Murray | 2010 - | Victoria |

NATIONAL SECRETARIES

| | | | |
|---|-------------|---------------------|-------------------|
| | G. Carlsen | 17.08.63 - 10.07.65 | New South Wales |
| | J. de Laroy | 10.07.65 - 26.08.67 | Victoria |
| | N. Osborn | 26.08.67 - 27.07.68 | Queensland |
| • | J. Hodgetts | 27.07.68 - 01.08.86 | South Australia |
| | K. Staples | 01.08.86 - 14.02.96 | Western Australia |
| | D. Clarke | 14.02.96 - 29.08.03 | Western Australia |
| | P. Arnett | 29.08.03 - | Victoria |

NATIONAL TREASURERS

| | | | |
|---|--------------|---------------------|-------------------|
| • | J. Duckworth | 29.03.64 - 27.07.68 | Victoria |
| | A. Gore | 27.07.68 - 02.08.85 | Victoria |
| • | F. Swann | 02.08.85 - 05.08.89 | Western Australia |
| | M. Harper | 05.08.89 - 01.08.91 | Queensland |
| | I. Gibb | 01.08.91 - 07.08.97 | Western Australia |
| | H. Johnston | 07.08.97 - 05.09.01 | New South Wales |
| | S. Glanville | 02.09.01 - 01.03.02 | New South Wales |
| | M. Sullivan | 20.06.02 - 06.02.03 | Tasmania |
| | A. Barclay | 29.08.03 - 30.04.04 | Victoria |
| | M. Laybutt | 27.9.04 - | New South Wales |

• Denotes Deceased

AUSTRALIAN KARTING ASSOCIATION INC

EXECUTIVE 2011

All contact details for executive to:

Australian Karting Association Inc. - National Office
PO Box 4222, Penrith Westfields PENRITH NSW 2751
Suite 2/483 High Street, Penrith NSW 2750
Phone: (02) 4721 1300
Fax: (02) 4721 1522
Email: admin@austkarting.com.au
Website: www.karting.net.au

General karting enquiries phone:

1300 30 KART (1300 305 278) - for connection to your relevant State



NATIONAL PRESIDENT

Mr Simon Whiting



NATIONAL VICE PRESIDENT

Mr David Murray



NATIONAL SECRETARY

Mrs Pam Arnett



NATIONAL TREASURER

Mr Max Laybutt

AUSTRALIAN KARTING ASSOCIATION INC

NATIONAL CO-ORDINATORS & OFFICERS - 2011



NATIONAL EVENTS COORDINATOR

Mrs Pam Arnett
C/- Maiden Gully Post Office
Maiden Gully VIC 3551
Tel: (03) 5449 6362
Mobile: 0409 334 175

Email: vka@bigpond.net.au



NATIONAL TECHNICAL COORDINATOR

Mr Les Allen
PO Box 4222, Penrith
Westfields
Penrith NSW 2751
2nd Floor, 483 High Street
Penrith NSW 2750
Mobile: 0458 617 532

Email: techcoord@austkarting.com.au



NATIONAL OFFICIALS COORDINATOR

Mr Brian Sparrow
7 Maxwell Street
Mount Gambier SA 5290
Tel: (08) 8725 7591

Email: bgakspar@bigpond.net.au



NATIONAL TRACK SAFETY COORDINATOR

Mr Mick Stott
21 Tingara Ave,
Evanston Park SA 5116
Tel/Fax: (08) 8522 4677

Email: stottm@bigpond.com

AUSTRALIAN KARTING ASSOCIATION INC

STATE DELEGATES TO THE NATIONAL KARTING COUNCIL - 2011



NEW SOUTH WALES

Mr Peter O'Neill
PO Box 495
St Marys NSW 1790
Tel: (02) 9623 4351
Fax: (02) 9623 4376

Email: administration@akansw.asn.au



VICTORIA

Mr Trevor Crane
C/- Maiden Gully Post Office
Maiden Gully VIC 3551
Mobile : 03 54825708

Email: vka@bigpond.net.au



QUEENSLAND

Mr Gavin Dicinoski
8 Jasmine Avenue
Gympie QLD 4570
Tel: (07) 49793379
Mobile: 0427 070 400

Email: akaqld@gmail.com.au



WESTERN AUSTRALIA

Mr Gary Light
C/- AKAWA State Office
Tel: (08) 9409 4441
Fax: (08) 9409 4441
Mobile 0419 914 069

Email: president@kartingwa.com.au



NORTHERN TERRITORY

Mr John Gatt
PO Box 40524
Casuarina NT 0811
Alawa N.T. 0810
Mobile: 0417 831 102

Email: akant@internode.on.net



TASMANIA

Mr Steph Peters
PO Box 174 Somerset
Tasmania 7322
Tel: (03) 6435 0266
Fax: (03) 6435 0299
Mobile: 0418 130 691

Email: steph@internode.on.net



SOUTH AUSTRALIA

Mr Craig Denton
C/- 216 Lady Gowrie Drive,
Largs Bay SA 5016
Mobile: 0419 718 672

Email: takasa@bigpond.com

AUSTRALIAN KARTING ASSOCIATION INC

STATE SECRETARIES / ADMINISTRATORS - 2011



NEW SOUTH WALES

Mrs Karen Newton
PO Box 495
St. Marys NSW 1790
Tel: (02) 9623 4351
Fax: (02) 9623 4376
www.akansw.com.au

Email: administration@akansw.asn.au



VICTORIA

Mrs Pam Arnett,
C/- Maiden Gully Post Office
Maiden Gully VIC 3551
Tel: (03) 9362 1144 or
(03) 5449 6362
Fax: (03) 5449 6442
Mobile: 0409 334 175
www.vka.asn.au

Email: vka@bigpond.net.au



QUEENSLAND

Ms Swaeha Ali
P.O.Box 4473
South Mackay QLD 4740
Mobile: 0409 945928
Fax: (07) 49512468
www.akaqld.asn.au

Email: akasec@akaqld.asn.au



WESTERN AUSTRALIA

Mrs Michelle Lino
421 Turner Way
Karratha WA 6714
Tel: (08) 9185 6466
Fax: (08) 9185 6477
Mobile: 0418 921 200

Email: secretary@kartingwa.com.au



SOUTH AUSTRALIA

Mrs Trisha Bartlett
216 Lady Gowrie Drive
Largs Bay SA 5016
Tel: (08) 8242 3513
Fax: (08) 8242 3513
www.karting.net.au

Email: takasa@bigpond.com



TASMANIA

Mrs Janine Evers
22 Hawthorn Drive
Kingston Tas 7050
Phone: (03) 6229 4892
Fax: (03) 6227 1119
Mobile: 0438 203 056
Web : www.akatas.iinet.net.au

Email: akatas.iinet.net.au



NORTHERN TERRITORY

Jenny Taylor,
PO Box 40524
Casuarina NT 0811
Tel: (AH) (08) 8945 2244,
Fax: (08) 8927 0730
Mobile: 0407 615 666

Email: akant@internode.on.net

NATIONAL OFFICE

PO Box 4222, Penrith Westfields
Penrith NSW 2751
2nd Floor, 483 High Street
Penrith NSW 2750
Tel: (02) 4721 1300
Fax: (02) 4721 1522
www.karting.net.au

Email: admin@austkarting.com.au

AUSTRALIAN KARTING ASSOCIATION INC

STATE PRESIDENTS - 2011

NEW SOUTH WALES

Mr Steven King
C/- PO Box 495, St Marys NSW 1790
Tel: (02) 9623 4351
Fax: (02) 9623 4376

Email: administration@akansw.asn.au

QUEENSLAND

Mr Gavin Dicinoski
C/- PO Box 6182, Fairfield QLD 4103
Tel: (07) 4979 3379
Mobile: 0417 931 892

Email: usathome@bigpond.net.au

SOUTH AUSTRALIA

Mr Ian Williams
C/- 216 Lady Gowrie Drive,
Largs Bay SA 5016 Tel: (08) 8340 9288

Email: takasa@bigpond.com

NORTHERN TERRITORY

Mr Tim Driscoll
C/- PO Box 40524, Casuarina NT 0811
Mobile: 0418 571 277

Email: akant@internode.on.net

VICTORIA

Mr David Murray
C/- Maiden Gully Post Office
Maiden Gully VIC 3551
Tel:(03) 9873 1838 Fax: (03) 9872 5774

Email: vka@bigpond.net.au

WESTERN AUSTRALIA

Mr Gary Light
C/- AKAWA State Office
Tel: (08) 9409 4441 Fax: (08) 9409 4441
Mobile: 0419 914 069

Email: president@kartingwa.com.au

TASMANIA

Mr Steph Peters
PO Box 174, Somerset TAS 7322
Tel: (03) 6435 0266 Fax: (03) 6435 0299
Mobile: 0418 130 691

Email: stephp@internode.on.net

JUDICIAL CONTACTS - 2011

AUSTRALIAN KARTING APPEALS COURT

C/- PO Box 4222,
Penrith Westfields, Penrith NSW 2751
Tel: (02) 4721 1300 Fax: (02) 4721 1522
Email: court@austkarting.com.au

Email: court@austkarting.com.au
admin@austkarting.com.au

AUST MOTOR SPORT APPEAL COURT

C/- PO Box 4222,
Penrith Westfields, Penrith NSW 2751
Tel: (02) 4721 1300 Fax: (02) 4721 1522

NATIONAL TRIBUNE REGISTRAR

Mr Warren Jeffrey
C/- PO Box 4222, Penrith Westfields,
Penrith NSW 2751
Tel: (02) 4721 1300 Fax: (02) 4721 1522

Email: court@austkarting.com.au

STATE TRIBUNE REGISTRARS

Please refer to your State Office

NATIONAL TECHNICAL COMMITTEE - 2011

VICTORIA

Mr Harold Arnett
C/- Maiden Gully Post Office
VIC 3551
Tel: (03) 5449 6207 Fax: (03) 5449 6442
Mobile: 0428 461 012
Email: vka@bigpond.net.au

QUEENSLAND

Mr Terry Sheedy
47 Cortess St
Toowoomba QLD 4350
Tel: 07 4690 2203 (w)
Mobile: 0418 747 215
www.akaqld.asn.au
Email: tsheedy@tmettec.com

WESTERN AUSTRALIA

Mr Ken Seeber
C/- AKAWA State Office
Tel: (08) 9306 1589 Fax: (08) 9306 1655
Mobile: 0438 061 589
Email: ken@strikeproducts.com.au

TASMANIA

Mr Mark Close
50 Forth Road, Turners Beach TAS 7315
Mobile: 0437 668 385
Email: tastech@iprimus.com.au

SOUTH AUSTRALIA

Mr Geoff Hall
C/- 216 Lady Gowrie Drive,
Largs Bay SA 5016
Mobile: 0418 805 100

NORTHERN TERRITORY

TBA
C/- PO Box 40524, Casuarina NT 0811
Email: akant@internode.on.net

NEW SOUTH WALES

TBA
C/- PO Box 495 St. Marys NSW 1790
Tel: (02) 9623 4351 Fax: (02) 9623 4376
Email: administration@akansw.asn.au

OFFICIALS COMMITTEE - 2011

VICTORIA

Mrs Sylvia Stania
C/- Maiden Gully Post Office,
Maiden Gully VIC 3551
Tel: (03) 9366 5483 Mobile: 0418324414
Email: vka@bigpond.net.au

TASMANIA

Mrs Janine Evers
22 Hawthorn Drive Kingston Tas 7050
Phone: (03) 6229 4892 Fax: (03) 6227 1119
Mobile: 0438 203 056
Email: akatas.iinet.net.au

WESTERN AUSTRALIA

Mrs Kim Light
421 Turner Way, Karratha WA 6714
Mobile: 0409 092 401
Email: officialcoord@westnet.com.au

NORTHERN TERRITORY

Mr Brenton Taylor
C/- PO Box 40524,
Casuarina NT 0811
Mobile: 0417 868 977
Email: akant@internode.on.net

SOUTH AUSTRALIA

Mr Rod Clee
C/- 216 Lady Gowrie Drive, Largs Bay SA 5016
Mobile: 0402 851 999
rodney.clee@three.com.au

QUEENSLAND

Mr Malcom Saunders
P.O.Box 4473, South Mackay QLD 4740
Home: (07) 4978 2341
Business: (07) 4971 4009
Mobile: 0429 260 144
www.akaqld.asn.au
Email: saundersfamily11@hotmail.com

NEW SOUTH WALES

Mr Howard Whitehouse
C/- PO Box 495, St Marys NSW 1790
Tel: (02) 9623 4351 Fax: (02) 9623 4376
Email: administration@akansw.asn.au

NATIONAL TRACK SAFETY COMMITTEE - 2011

NATIONAL INSPECTOR

Mr Mick Stott
21 Tingara Road,
Evanston Park SA 5116
Tel/Fax: (08) 8522 4677
stottm@bigpond.com

WESTERN AUSTRALIA

Mr Mike Sully
C/- AKAWA State Office
Tel: (08) 9410 1497 Fax:(08) 9410 2122
Email: mike@kartshop.com.au

SOUTH AUSTRALIA

Mr Graham Jensen
C/- AKA SA 216, Lady Gowrie Drive SA 5016
Mobile: 0408 854 359
Email: akasa@senet.com.au

NEW SOUTH WALES

STATE TRACK INSPECTOR

Mr Tom Nipperess (Sth Zone)
C/- PO Box 495, St. Marys NSW 1790
Tel: (02) 9623 4351 Fax: (02) 9623 4376
Email: administration@akansw.asn.au

Mr Tracy Stewart (Nth Zone)
C/- PO Box 495, St. Marys NSW 1790
Tel: (02) 9623 4351 Fax: (02) 9623 4376

Mr Richard Catford (West. Zone)
C/- PO Box 495, St. Marys NSW 1790
Tel: (02) 9623 4351 Fax: (02) 9623 4376

Mr Jeff Burton (Speedway)
C/- PO Box 495, St. Marys NSW 1790
Tel: (02) 9623 4351 Fax: (02) 9623 4376

VICTORIA

Mr Ross Gathercole
C/- Maiden Gully Post Office
Maiden Gully VIC 3551
Mobile: 0428 293 292
Email: vka@bigpond.net.au

TASMANIA

Mr Steven Sims
Woodchoppers Lane, Sprent . Tas 7315
Tel /Fax: (03) 64 293125 Mobile: 0419547145
Email: kartcentral@bigpond.com

NORTHERN TERRITORY

Mr Tim Driscoll
C/- AKA NT, PO Box 40524 Casuarina NT 0811
Mobile: 0412 419 344
Email: akant@internode.on.net

QUEENSLAND

Mr Alf Capri (Sth Zone)
42 Means St
Fairfield QLD 4103
Tel: (07) 3844 4276
www.akaqld.asn.au
Email: info@alfcapriengines.com.au

Mr Peter Thomas (Nth Zone)
C/- PO Box 6182 Fairfield QLD 4103
Tel/Fax: (07) 4787 3773 (W)
Mobile: 0428 981 787
Email: tcasct@hotmail.com

INTERNATIONAL KARTING COMMITTEE - 2011

CIK DELEGATE

Mr Craig Denton
C/- PO Box 4222, Penrith Plaza,
Penrith NSW 2751
Mobile: 0419 718 672
Email: admin@austkarting.com.au

MEMBER

Mr Kel Tresider
C/- PO Box 4222, Penrith Plaza,
Penrith NSW 2751
Mobile: 0418 597 599
Email: admin@austkarting.com.au

SERIES COORDINATOR

Mr Peter Galvin
C/- PO Box 4222, Penrith Plaza,
Penrith NSW 2751
Tel: (02) 4721 1300 Fax: (02) 4721 1522
Email: admin@austkarting.com.au

MEMBER – TECHNICAL OFFICER

Mr Richard Erdmann
c/- PO Box 4222, Penrith Plaza,
Penrith. NSW 2751
Mobile: 0418 444 068
Email: admin@austkarting.com.au

2010 Australian National Sprint Kart Championships

RESULTS - National Sprint Kart Championships

HELD AT: EASTERN LIONS KART CLUB, SEYMOUR TOOBORAC RD, PUCKAPUNYAL , VICTORIA

DATE: 2/3/4th April 2010

| CLASS | 1ST | STATE | 2ND | STATE | 3RD | STATE |
|------------------------------|-----------------|-------|-----------------|-------|----------------|-------|
| Senior National Heavy | Aaron Johnstone | VIC | Corey Lean | NSW | Matthew Waters | NSW |
| Senior National Light | Dale Beaton | VIC | Aaron Johnstone | VIC | Ryan Reynolds | NSW |
| Clubman Heavy | Shayne Piper | NSW | Zeke Edwards | VIC | Shane Price | VIC |
| Clubman Light | James Sera | VIC | Jordon Ford | VIC | David Sera | VIC |
| Clubman Super Heavy | Josh Brooker | VIC | Ben McKindlay | QLD | Jason Stania | VIC |
| Junior National Light | Joseph Maswon | NSW | Phillip Munnery | VIC | Liam Morey | VIC |
| Junior National Heavy | Jordon Nicolaou | VIC | Mason Thomas | VIC | Macauley Jones | VIC |
| Junior Clubman | Joseph Mawson | NSW | Simon Hodge | SA | Jesse Elliott | WA |
| Leopard Heavy | Lee Mitchener | VIC | Matt Greenbury | QLD | Brendan Nelson | QLD |
| Leopard Light | Dean Foster | VIC | Adam Hughes | VIC | Adam Willison | VIC |

RESULTS - CIK Stars of Karting Series

| CLASS | 1ST | STATE | 2ND | STATE | 3RD | STATE |
|--------------------------|-----------------|-------|----------------|-------|--------------------------|------------|
| Pro Light (KF1) | Cian Fothergill | QLD | Hayden McBride | NSW | Joel Smith & Grant Smith | VIC VIC |
| Pro Gearbox (kZ2) | Matthew Wall | VIC | Kel Treseder | QLD | Troy Woolston | VIC |
| Pro Junior (KF3) | Pierce Lehane | NSW | Brock Plumb | QLD | James Macken | QLD |

RESULTS - Formula 100 Nationals

HELD AT: Geelong Kart Club

DATE: October 23 & 24th 2010

| CLASS | 1ST | STATE | 2ND | STATE | 3RD | STATE |
|--------------------------|--------------|-------|------------------|-------|-----------------|-------|
| Formula 100 Light | Adam Hughes | VIC | Sarron Caddy | VIC | Mark Domaschenz | VIC |
| Formula 100 Heavy | Remo Luciani | VIC | Dominic Albanese | VIC | Matthew Mills | VIC |

RESULTS - Rotax Nationals

HELD AT: Ipswich Kart Club

DATE: September 3/4/5th 2010

| CLASS | 1ST | STATE | 2ND | STATE | 3RD | STATE |
|--------------------|-----------------|-------|---------------|-------|-----------------|-------|
| Rotax Light | David Sera | VIC | Kyle Ensby | QLD | Troy Bretherton | QLD |
| Rotax Heavy | Simon Meyer | NSW | Jason Pringle | VIC | Rick Pringle | VIC |
| Formula JMA | Jonathan Venter | NSW | Hayden Cooper | QLD | Pierce Lehane | NSW |

ADMINISTRATIVE PROCEDURES

A1 Communications must follow the official path:

- a) From club member to club secretary, from Club Secretary official correspondence (letterhead) to State Office to National Office for forwarding to other bodies involved.
- b) Replies are to follow reverse procedures.
- c) Under exceptional circumstances, the National Executive may communicate directly with National Council, National Track Committee, National Technical Committee or the National Officials Committee and vice versa.

Responsibilities of National Officers

A2 National President

The National President will

- a) attend all meetings as requested by the Council;
- b) preside at all meetings of the secretariat, the council and committees;
- c) carry out the directions of the Council;
- d) Oversee all officers of the Secretariat;
- e) Oversee all Legal issues;
- f) Liaise with other motor sport bodies.

A3 National Vice President

The National Vice President will

- a) prepare, in conjunction with the treasurer, a budget for the approval by the Council, and monitor and report on performance against the budget.
- b) prepare tender invitations and administer tenders in conjunction with the Admin Tech Officer;
- c) prepare, in conjunction with specialist committees, policy statements and specific purpose manuals for approval by the Council;
- d) liaise with State karting administrations and develop an effective system of collecting statistical information;

A4 National Treasurer

The National Treasurer will

- a) Attend all meetings as requested by the President;
- c) Preparation of the National budget;
- d) Prepare monthly financial reports for consideration by the Council;
- e) Compilation of license data;
- f) Liaise with the Auditors;
- g) Assist with Insurance Matters

A5 National Secretary

The National Secretary will

- a) Oversee the organisation of national and international events;
- b) Be responsible for the issuing of permits and licences for which the National Office are responsible for;
- c) Assist all other members of the Secretariat.
- d) Liaise with Office staff on day to day issues as required
- e) Oversee collating of agenda's and minutes of meetings

A6 National Technical Coordinator

The National Technical Coordinator will

- a) attend all meetings as required by the Council or President;
- b) coordinate the National technical advisory committee, and act as the means of communication between the committee and the Council;
- c) advise all the State Technical Advisers;
- d) ensure a consistent interpretation of the technical rules in each state;
- e) collect and evaluate interpretations from each State Technical Advisor and circulate
- f) carry out the directions of the Council.

A7 National Events Administrator

The National Events Administrator

- a) Attend all meetings as requested by the President;
- b) In conjunction with the President be responsible for:
 - National Championships
 - Overseeing of CIK
 - Liaison with promoters and Events Officials
 - Venue Evaluation and Selection
- c) Collect and evaluate information relating to National Championships and advise Council;
- d) Where the NKC is required to select the host club for National Championship:
 - report to the NKC on each submission on their suitability, i.e. track, facilities, at the AGM
- e) Establish a database re - entries, consumables and facilities of each National Championship attended so as to:
 - Provide information to the clubs at least 2 years prior to event;
 - Liaise with appointed club officials (max 2) answering enquiries and requirements;
 - Report to the President of any matter of concern regarding progress or scheduling;
- f) Examine Supplementary Regulations; (in conjunction with National Officials Co-coordinator prior to approval);
- g) Attend the National Championships in an advisory capacity from a period 48 hours prior to the first official practice;
- h) Attend all meetings requested by Council or the President; and take directives from Council.

A8 National Medical Officer

The National Medical Officer will

- a) bring to the attention of the Council any matter relating to the health or safety of karters, officials or spectators which he/she believes requires action by the Council;
- b) advise the council on any matter referred to him/her;
- c) liaise with state councils on any medical issues;
- d) establish a national policy on medical issues;
- e) attend meetings at the request of the Council or the President

A9 National Officials Coordinator

The National Officials Coordinator will

- a) attend all meetings as required by the Council or President;
- b) coordinate the National Officials Committee, and act as the means of communication between the Committee and the Council;
- c) advise the State Officials Coordinator;

- d) in conjunction with the State Officials Coordinator, ensure at least one Officials school is conducted in each state each year;
- e) ensure a consistent interpretation of the rules in each state;
- f) collect and evaluate interpretations from each State Official Coordinator and from tribunals and circulate if appropriate;
- g) carry out the directions of the Council.

A10 National Track Safety Coordinator

The National Track Safety Coordinator will

- a) attend all meetings as required by the Council or President;
- b) coordinate the National Track Safety Committee, and act as the means of communication between the committee and the Council;
- c) advise the State Track Safety Inspectors;
- d) inspect, or nominate an interstate track safety inspector to inspect all temporary circuits.
- e) in conjunction with the State Track Safety Officer, ensure at least one track safety school is conducted in each state each year;
- f) ensure a consistent interpretation of track safety rules in each state;
- g) carry out the directions of the Council;
- h) may inspect the tracks at the request of the NKC/ State Karting Councils.

A11 National Publicity Officer

The National Publicity Officer will

- (a) Oversee the development and updating of the AKA Web Site;
- (b) Develop promotional material such as brochures, videos, etc.;
- (c) Coordinate advertising in general media;
- (d) Issue press releases to:
 - i) Karting media re: major policy changes or events of National interest
 - ii) General media re: events of National importance;
- (e) Disseminate promotional ideas to clubs and state bodies.

A12 Delegate to the CIK

The delegate to the CIK will

- (a) Act as AKA representative to meetings of the CIK as and when requested by the NKC/IKC.
- (b) Provide written reports on all such meetings to the NKC and IKC.
- (c) Receive and distribute all correspondence relating to CIK issues.
- (d) Monitor International issues and provide timely notification of relevant issues.

A13 National Prosecutor

The appointment of the National Prosecutor shall be made by the NKC at the Annual General meeting of the AKA and such appointment shall be for a period of 12 months.

The principal role of the National Prosecutor is to act on the instructions of the AKA Secretariat and appear on its behalf in the AKAC and when required in the AMSAC as their advocate.

Refer to policy document AKAPD04 available from the National Office or at www.karting.net.au

A13.1 National Tribunal Registrar

The appointment of the National Tribunal Registrar shall be made by the NKC at the Annual General meeting of the AKA and such appointment shall be for a period of 12 months. The principal role of the National Tribunal registrar (NTR) is to ensure that the Australian appeals court (AKAC) functions in an efficient and proper manner and that the rules of the AKAC are complied with.

The officer of the National tribunal registrar (NTR) is an administrative position not a judicial position.

Refer to policy document AKAPD05 available from the National Office or at www.karting.net.au

A14 National Technical Committee

A14.1 Members

The members of the Committee are:

- a) a delegate appointed by each state karting council (as voting members); and
- b) the National Technical Coordinator as convener.

A14.2 Duties

The duties of the Committee are:

- (i) to advise the Council, the State Karting Associations, clubs and competitors on matters relating to kart specifications;
- (ii) to consider proposals for changes to the technical regulations, and make recommendations to the annual conference;
- (iii) to consider other matters referred to it by the Council, and make recommendations to it.

A15 National Track Safety Committee

A15.1 Members

The members of the Committee are:

- a) a delegate appointed by each state karting council (as voting members); and
- b) the National Track Safety Officer as convener.

A15.2 Duties

The duties of the Committee are:

- (i) to advise the Council, the State Karting Associations, clubs and competitors on matters relating to track safety and the safety of competitors, pitcrew, officials and spectators;
- (ii) to approve new tracks and/or major alterations to existing tracks;
- (iii) to promulgate guidelines on track layout and on any issue of safety which it believes requires attention.

A16 National Officials Committee

A16.1 Members

The members of the Committee are:

- a) a delegate appointed by each state karting council (as voting members); and
- b) the National Officials Coordinator as convener.

A16.2 Duties

The duties of the Committee are:

- (i) to formulate standards for stewards and a system of grading;
- (ii) to recommend changes to the regulations relating to the control of race meetings and the disciplinary system;
- (iii) to consider matters referred to it by the Council, and make recommendations to it.

A17 International Karting Committee (IKC)

A17.1 Members

The members of the Committee will be:

- a) CIK delegate, Coordinator CIK Championships, CIK Technical Officer plus two additional members. In addition, any other members as the Committee may request and as approved by the NKC.
- b) The CIK Delegate, Coordinator CIK Championships, CIK Tech Officer and two committee members will be called for in accordance with R10A (a) (i) and will be appointed by the NKC at the AGM.
- c) The Chairman is appointed by the IKC from the Committee Members.
- d) The tenure of the committee will be from the completion of the current years CIK series to the completion of the following years CIK series.
- e) The NKC has the power to fill any casual vacancies between AGM's from recommendation from the IKC.

A17.2 Duties

The duties of the Committee are:

- (i) to monitor technical and sporting regulations governing the organisation and promotion of CIK sprintkart classes;
- (ii) to make recommendations to the NKC in relation to matters pertaining to CIK sprintkart class competition conducted in Australia and Internationally;
- (iii) to monitor the promotion and organization of the CIK/FIA Oceania Championships and the Australian Championships for CIK classes;
- (iv) to recommend to the NKC the allocation and organization of the CIK/FIA Oceania Championships and the Australia Championships for CIK classes;
- (v) to maintain the point score of the Australian Championships for CIK classes;
- (vi) to recommend to the NKC the allocation of Australian Sports Commission funds specifically granted for funding international sprintkarting;
- (vii) to recommend to the NKC the delegate and co-delegate to the CIK.

A18 Duties of State Karting Councils

The duties of State Karting Councils may include:

- (i) collecting and remitting relevant fees, levies and other monies to the AKA;
- (ii) issuing and recording licences and permits;
- (iii) collating statistics and forwarding them to the AKA;
- (iv) keeping records of tribunal decisions and ensuring that the penalties and warnings are endorsed on licences;
- (v) drafting state calendars;
- (vi) determining conditions for state karting championships and series;
- (vii) arbitrating intrastate disputes not otherwise provided for in the national competition rules;
- (viii) to ensure recommendations of national officers and committees, are acted upon.

A19 References to National Secretary

Except in the registered rules, a reference in this manual to the National Secretary is to be taken as a reference to the Chief Executive Officer.

A20 References to Chief Executive Officer

Except in registered rules, a reference in this manual to the Chief Executive Officer is to be taken as a reference to AKA Secretariat during periods when the Chief Executive Officer position is vacant.

DEFINITIONS

Definitions: (Of Bodies)

AKA Australian Karting Association (Inc) The Association of affiliated state karting associations in Australia.

AMSAC Australian Motor Sport Appeal Court The final appeal tribunal.

ASN or "Recognised Automobile Club"

A national governing body of automobile competitions, recognised as such by the FIA. The Regulations made by such a body for the control of competitions shall be referred to as the National Competition Rules of the Country.

CIK The International Karting Commission being appointed by the FIA to deal with competition matters.

Club A body organised to promote and foster the sport of Karting.

Code International Sporting Code.

FIA The International Federation of "Recognised Automobile Clubs."

NKC National Karting Council of Australia. The Executive Committee of the AKA.

National Technical Advisory Committee

The Committee responsible to the NKC on technical matters related to Kart and Engine specifications.

National Track Safety Committee

The Committee responsible to the NKC on matters of track design and safety.
(SKC State Karting Council.

Definitions: (General)

Addendum (to Supplementary Regulations)

A form listing further information which was not available when the Supplementary Regulations were written and to be read in conjunction with the Supplementary Regulations. These too must be approved by the **AKA/SKC** prior to distribution and cannot alter the previously issued regulations except for reasons of force majeure or safety. If there is less than 7 days before a race meeting, this may be issued in the form of a Bulletin at the race meeting, signed by the Stewards and all drivers notified.

Advocate

Somebody who pleads the cause of another before a hearing, tribunal or court.

Australian Kart Formula

The specifications for karts under the heading set out in these regulations.

Baulk Line

The baulk line is the limit to which the kart may be pushed.

Bulletin

These cannot change the previously issued regulations except for reasons of force majeure or safety. They must be posted on the notice board and all drivers advised of the posting.

Carburettor Jet

A device that regulates the volume of fuel that passes beyond that point.

Chassis

Consists of the frame and components except the tyres and engine.

Class

A classification of Karts as determined by the NKC from time to time.

Compete

A competitor is deemed to have competed in a section of an event if they have exited the out grid under direction from the grid marshal and proceeded past the baulk line under their own motive power, for a competition.

Competition

Any race, test, time trial, speed event or combination of the aforesaid in which a Kart may participate and which has a competitive nature or is given a competitive nature by the publication of results. Competitions may be International, National or State. State Competitions may moreover be either OPEN or CLOSED. An OPEN Competition is one in which the entry is permitted of any person holding a Sprint Kart Licence as hereinafter described. CLOSED Competitions are those which are confined to the members of the Club, Clubs or State organising the competition.

Competitor

A person who is the holder of a current AKA licence and whose entry is accepted for any competition whatsoever. The term "Competitor" shall imply "Entrant" and vice versa. (Refer rule 13.01.)

Control Line

A control line is a line by reference to which a kart is timed or its performance in a competition is determined.

Course

The route to be followed by karts in a competition.

Cylinder Volume

The volume swept in cylinder or cylinders by the upward or downward movement of the piston or pistons in such cylinder or cylinders. Cylinder volume shall be expressed in cubic centimetres. For all calculations relating to the cylinder volume of engines the symbol [!] will be regarded as 3.1416.

Data Logger

Any device that can store information to be retrieved at the end of a session.

Did Not Start (DNS)

A competitor is deemed to be a DNS if they have not satisfied the definition of "compete", above.

Did Not Finish (DNF)

A competitor is deemed to be a DNF if they have not completed the required number of laps in heats, pre final or final, or greeted by the chequered flag to signify the completion of that section of the event, unless competitor was shown the blue and red double diagonal flag, Refer to rule 15:13.

Driver

Any person nominated as the driver of a kart in any competition whatsoever.

Entrant

A person who is the holder of a current AKA licence and whose entry is accepted for any competition whatsoever. The term "Entrant" shall imply "Competitor" and vice versa. (Refer Rule 13.01.)

Event

All competitions for one class at the one meeting except as allowed for in rule 16.06(d).

Exclusion

To expel from a place or position previously occupied. For the purposes of lap scoring / recording, when a competitor is excluded from a section of an event, an event or a meeting, their relevant placing / points entitlement will be assumed by the relevant succeeding competitor with all subsequent placings / points adjusted accordingly.

Field

Consists of class/es on the track at that time.

Finishing Line

A finishing line is the last control line on a course

Frame

Welded main tube structure and applicable rails in the manufacturer's specifications and regulations.

Handicap

The method laid down in the Supplementary Regulations of a competition for the purposes of equalising the chances of the competitors.

Heat

One of a series of races in which the combined results of the heats shall determine the leader at that point.

Kart

An automobile complying with the specific requirements of these regulations.

Licences

The licence card of registration issued by the SKC to a qualified person wishing to compete in Kart competitions, known as a Sprint Kart Licence. The certificate of registration of a track suitable for Kart competitions, known as a Kart Track Licence. No competition shall be permitted on any track in respect of which such licence has not been issued by the SKC.

Licence Number

The number of a Sprint Kart Licence. Such number shall be preceded by a letter indicating the State of issue.

Licence Register

The list maintained by the AKA of persons to whom a Sprint Kart Licence has been issued. The register must show the relevant licence numbers.

Maximum/Minimum

References of Maximum or Minimum mean the absolute dimension for that item.

Meeting

An assembly of competitors and officials which include one or more competitions other than one individual attempt at a record.

National Speed Event

Shall be either "Public" or "Private", as defined hereunder. Public events are those events in respect of which the public is, or has been beforehand, invited to attend, by means of advertisements or publicity of any kind, or using any medium. Private events are, on the other hand, those in respect of which no prior publicity of any kind shall have

been published to the general public. It shall not be necessary for the purpose of this rule for a specific and general invitation to attend to have been published. Any announcement of intention to hold such a meeting, made to the public at large, other than the Australian Kart Calendar or in official State Calendars published by the AKA, shall be deemed to constitute such a meeting as "Public" defined above.

OEM

Original Equipment Manufacture - Item must be the same as samples held in the AKA National Office and must conform to the specifications in the current AKA Manual.

Organising Committee

A committee of at least three persons approved by the AKA and authorised by the promoters to organise a meeting on their behalf. When an organising committee is appointed to act on behalf of the promoters, such organising committee shall take the place of such promoters for the purpose of the rules, except that the promoters shall be responsible for the acts and omissions of such organising committee as if such acts and omissions were their own.

Organising Permit

A documentary authority to organise and hold a competition granted solely by the AKA.

Programme

A document prepared by the promoters or organising committee of a race meeting for the purpose of informing the participants and spectators about such a meeting.

Promoters

Any person or body (other than an organising committee) proposing to hold, holding or organising a meeting.

Prosecutor

A person who institutes or conducts an official prosecution.

Race

A competition between karts running simultaneously on the same course, and in which finishing order or time is the determining factor.

Race Track Area

Inside main safety fence.

Record

The best result obtained under the prescribed conditions.

Secretariat

The Secretariat of the AKA, as set out in the Rules of the AKA.

Speed Event

Any event of more than 200 metres in a forward direction marked and which is determined by outright speed alone. The term "Speed Event" shall include races, attempts at a record, hill climbs and speed acceleration tests by whatever name.

Sprint Race

A race on a circuit not exceeding 1.7 kilometres per lap in size.

Stock

Stock standard, no modifications. Must be same as the samples held in the AKA National Office and must conform to the specifications in the current AKA Manual.

Supplementary Regulations

Regulations supplementary to these rules, drawn up by a promoter or promoters or organising committee of a competition or competitions and approved by the **AKA/SKC**, with the object of laying down details of such competition. Such regulations shall not be contrary to the Supplementary Regulations as laid down in the manual for State and National Championships nor to the Australian Kart Formulae which may not be altered, added to or amended, by way of Supplementary Regulations.

Telemetry Aids

Any device that relays information from the kart to another party whilst the vehicle is in motion.

The Start

The start is the moment when the order to start racing is given to a competitor or competitors.

Track

A permanent course (being an agreed track defined by a single line, curbs and ripple-strips at each side of the course) or a temporary course (being an agreed track defined by temporary markings, barriers, or as defined by the organisers) used for competitions, including record attempts.

Tribunal Registrar

The person designated by the AKA in each State to arrange Tribunals as per rule 4.25(b).

Tyres

An approved new or used tyre is one of the same type.

Wet Weather Tyre

Tyre specifically manufactured for wet weather use.

The Start

The start is the moment when the order to start racing is given to a competitor or competitors.

Track

A permanent course (being an agreed track defined by a single line, curbs and ripple-strips at each side of the course) or a temporary course (being an agreed track defined by temporary markings, barriers, or as defined by the organisers) used for competitions, including record attempts.

Tribunal Registrar

The person designated by the AKA in each State to arrange Tribunals as per rule 4.25(b).

Tyres

An approved new or used tyre is one of the same type.

Wet Weather Tyre

Tyre specifically manufactured for wet weather use.

CHAPTER 1

GENERAL STANDING REGULATIONS

Preamble:

These are the General Standing Regulations of the Australian Karting Association Inc (AKA). The object of these regulations is to ensure that the conduct and promotion of the sport of karting in Australia is carried on in a manner which enhances and secures the safety of spectators, officials and competitors, and which encourages the sport to be competitive and fair for all who take part.

1.01 Authority:

The National Karting Council (NKC) of the Australian Karting Association Inc. (AKA), has drawn up these regulations for the control of the sport of karting under its authority in Australia. Karting will be organised in Australia by the AKA as the delegated body or, by other promoters approved by the NKC.

1.02 Application:

These regulations shall govern all practice and competitions in which karts as hereinafter defined shall take part.

1.03 Spirit and Intent:

The AKA makes no pretence of having designed a fool-proof set of rules and regulations. Nevertheless, under the Constitution of the AKA, these rules and regulations will be periodically reviewed towards safer and fairer competition for all.

1.04 Entrants, drivers and participants in general are required to be fully conversant with these regulations and supplementary rules or instructions governing any event and are (by reason of their entry therein) definitely bound by such regulations, supplementary rules or instructions.

1.05 By the mere fact of entering an AKA event, every participant agrees to abide by these regulations and the Supplementary Regulations, Addendums and Bulletins pertaining to that event and recognise as the only authority the officials of that event, and above these, the Competition Committee of the AKA.

Officials of any race meeting shall have (and exercise) their powers during the entirety of the race meeting.

All AKA licence holders, whether competing or not, are bound by the Association's rules at all times when attending AKA sanctioned events.

Drivers will at all times be responsible for the conduct of their crews, and any offence committed by a crew member will be chargeable directly to the competitor. A driver's parent / guardian in the pit / paddock area will be automatically classed as a pit crew member.

1.06 Acquaintance With and Submission to Rules:

Every person, body or group of persons organising a competition or taking part therein, or applying for an organising permit, or applying for a licence from the NKC, or entering for a competition, or accepting any official position in the AKA, or to any judicial tribunal set up under these rules, or applying for affiliation or association with the AKA will be deemed to have and recognise that they have:

(a) Made themselves acquainted with these Rules, and

(b) Submitted themselves without reserve to the consequences resulting from these Rules and any

subsequent alteration thereof, and

(c) Renounced, under pain of disqualification the right to have recourse, without the written consent of the NKC or Tribunal not provided for in these Rules.

1.07 Organising Permit; Necessary Permission and Approval.

No competition shall be held under these rules unless the AKA or the SKC has signified its approval by granting an Organising Permit, with or without a Permit Fee, or the competition is of a kind in respect of which the AKA or SKC may attach conditions to the granting of a Permit or decline to grant or may withdraw a Permit without stating a reason.

Every application for an AKA Race Permit shall be made electronically via the AKA Race Management System, complete with attached supplementary regulations. It must be lodged with the Secretary of a SKC at least one month before the proposed meeting.

1.08 Announcement of Jurisdiction:

Race meetings will be held under the **General Standing Regulations** and **National Competition Rules** of the AKA. All supplementary regulations and programmes for all Kart competitions shall bear conspicuously the announcement: -"Held under the International Sporting Code of the FIA, and the **General Standing Regulations** and **National Competition Rules** of the AKA".

1.09 Format and Results:

Supplementary Regulations for all meetings shall specify the format and schedule of racing and the method of determination of results.

1.10 Track Licence:

A Track Licence is issued annually by the S.K.C. after approval has been granted by the State Track Inspector. A Track Licence is a permit that allows the circuit to be used by AKA Licenced drivers for practice and /or approved competitions. A current Track Licence empowers the relevant S.K.C. / Club Executive or Licenced AKA Officials to enforce these rules and regulations at all times whenever the circuit is used for practice and / or approved competition.

Clubs that do not have a track licence but hire their circuits may apply to their relevant S.K.C. for a practice permit as and when required.

1.11 Insurance:

Organisers, officials, drivers, pit crews and voluntary workers are covered by the AKA's **Personal Accident Insurance Policy** and shall comply without exception with such requirements regarding insurance as may be decided by the NKC from time to time, (Refer to Chapter 3 for details and limitations).

1.12 Fees:

The scale of fees payable shall be such as are determined from time to time as detailed in Chapter 2. -Fees.

1.13 Duration of a race meeting

A race meeting commences at the commencement of the first date specified on the Organising Permit and ceases at the expiration of the final date specified on the Organising Permit. During this entire period, the appointed officials of the race meeting shall have (and exercise) their powers.

1.14 Entries

Entry to all race meetings must be by use of the plastic AKA license swipe card in conjunction with the CM;S for identification and confirmation of entry.

1.15 Acceptance of Entry:

The Organisers reserve the right to reject any entry without giving any reason whatsoever or to attach conditions to acceptance of an entry. These conditions must not be contrary to AKA regulations. The AKA or the SKC may direct the Organisers to accept an entry.

1.16 Identifying Marks (Scrutineering):

Each kart shall have affixed to it a correct scrutineering sticker or identifying mark supplied for that meeting. This signifies that the driver has confirmed their entry for the meeting and completed a Scrutineering Form relevant to the entry. The Grid Marshal / Scrutineers shall not allow any kart that does not display a correct scrutineering sticker or identifying mark to practice, time trial, qualify or race. Failure to comply will result in the driver being excluded from the Meeting. Refer to rule 12.01(a).

1.17 Kart Formulae:

All karts **must** comply with the Australian Kart Formula **and relevant class regulations at all times during all practice and competitions.**

1.18 Weights:

Class weights are as raced at the time of weight measuring as per rule 25.19 and are detailed in the relevant class chapters of this manual.

1.19 Running in an engine:

When a competitor is running in an engine(s) during practice they must display a diagonal RED cross **over their race number** on the rear number plate. This cross must **go from corner to corner of the number plate** and be clearly visible.

1.20 Re-Scrutineering:

Karts damaged during practice or racing due to an accident are required to be returned to the scrutineering bay for examination by scrutineers. They will not be released to entrants other than upon the direction of the Chief Scrutineer.

1.21 Post Event Scrutineering:

Motors and karts may be measured for conformity to the Rules prior to the provisional placings being announced. Motors to be removed from the kart, if required by the Technical Inspector and be presented immediately upon conclusion of the event in a tidy and clean condition. Responsibility of removing and reassembling motors is that of the competitor concerned. Provisional placed drivers not intending to compete in final heat of Class must present motors and kart to appropriate Official immediately on their retirement from Class. The driver or his/her representative may elect to be present at time of Technical Inspection.

1.22 Withdrawal from an event:

Should a competitor decide NOT to compete in a section of an event for which they have entered, it is a requirement that they immediately notify the Grid Marshal, whose responsibility it shall be to notify the other relevant officials.

1.23 Advertising:

Advertising is allowed on karts or driver's overalls or helmets, subject to the following conditions:

- (a) No advertising to be closer than 50mm from the number background.
- (b) No numerals are allowed. AKA Promotional material exempt.
- (c) No advertisements in bad taste will be permitted.

The Stewards shall have the sole responsibility for the definition of bad taste.

Apart from the above requirements the style, size, number, location and subject matter of advertising on karts shall be free.

The Clerk of the Course and the Stewards can direct that a sign be removed or covered if they consider it contravenes any of the above regulations. Their decision shall not be subject to appeal in respect of that Meeting.

1.24 UNAUTHORISED Competitions:

AKA licence holders participating in events not authorised by the AKA will forfeit all entitlements contained within their AKA Licence during or arising from that event.

1.25 Alteration to Competition:

Unless otherwise stated in the approved supplementary regulations of a meeting, the Organisers reserve the right at their sole discretion to abandon, postpone, cancel or alter the race distance of any event(s).

1. Cancellation (the proposed meeting or competition never taking place) In the case of the cancellation of a race meeting or a competition forming part of a meeting entry fees shall be returned.
2. Postponement (the meeting or competition cannot begin or be completed on the proposed date). In the case of a postponement for more than 24 hours, entry fees shall be returned on a written request (e.g. email / fax) by the entrant within 14 days from the postponement. If this has not been received, the entrant will be re-entered into the re-scheduled event. AKA / SKC / Promoting Club and Stewards of the Meeting have the authority to order postponement and they may only do so for reasons of "safety" or "force majeure" as per Rule 4.09(k).
Supplementary Regulations for race meetings postponed for more than 14 days can be altered and re-issued to allow for changes of officials, entries and timetables.
3. Abandonment (is the act of giving up before completion of the meeting or a competition forming part of a meeting, and, if possible, results are declared) Only the Stewards of the Meeting have the authority to order abandonment and they may only do so for reasons of "safety" or "force majeure" as per Rule 4.09 (k). Where no result can be declared or abandonment is for more than 50% of the scheduled competitions, then the entry fees shall be returned.
4. Alteration of Race Distance
For all events except State and National Championship events, the Stewards and Clerk of Course, in conjunction with the Promoting Club, may alter (increase or reduce) the original specified race distance. Drivers must be notified and a Bulletin issued.

"force majeure" means "circumstances over which the organisers have no control and which involve the impossibility of the completion of the contest."

1.26 Distribution of Prizes:

- (a) The distribution of prizes must not commence until one hour after the completion of events in that Class.
- (b) A prize must not be distributed if the decision on a Complaint might affect it, until the Complaint is dealt with and;
 - (i) any appeal is finalised or
 - (ii) the time for appeal has expired without any notice of appeal having been lodged.
- (c) Any list of results and prizes published prior to the expiration of time for the lodgement of complaint, or affected by an uncompleted Complaint or Appeal must be stated to be provisional.

1.27 Local Club Events:

"LOCAL CLUB EVENTS" may be run in accordance with local conditions and entries, but must comply with the relevant Australian Kart Formula. These events do not apply to a State Championship or State Closed Titles. All aspects of this specifically created class must be listed on the supplementary regulations and approved by the State Karting Council on an event-by-event basis.

1.28 Fuel Sample:

Fuel samples may be taken as required, by methods as per Chapter 22.

1.29 Change of Chassis:

Replacement of chassis shall be permitted, if after inspection by Stewards and/or Scrutineers it is determined that the damage to the original frame is beyond repair in the time available, prior to next heat, time trial, etc. The replacement chassis must be scrutineered for compliance with kart specifications and regulations.

1.30 Change of Motors:

1. The maximum number of engines permitted for use on a kart at a meeting is as per chart, unless stipulated otherwise in supplementary regulations. Championships events must be as per chart.

| Class | Maximum Number of Engines | Number of identification Seals/Tags |
|---|---------------------------|-------------------------------------|
| Formula 100 | 3 | 3 |
| Twin or 2 x 100cc engines | 4 | 6 |
| All other classes | 2 | 2 |
| CIK – refer chapter 43 OR Event Supplementary Regs | 3 | 3 |

2. Either the engine make, model and number OR numbered seal/tag is required on the scrutineering report as a means of identification for final Technical Inspection and for spot

checking during competition.

3. If engine identification tags/seals have not been issued and recorded at scrutineering then the replacement motor, which is required for use, must be presented to the Scrutineer for recording of appropriate identification.
4. Components/accessories may be also marked or sealed and number recorded to provide a means of identification for final engine inspection and for spot checking during competition.
5. If a motor, component or accessory that has been marked, sealed or recorded in anyway, is required to be replaced, then it must first be presented to the Scrutineer for technical inspection, except when the replacement motor has been sealed/tagged and recorded on the scrutineering report form.
6. Seals may only be removed by the Scrutineer.
7. All motors that have been scrutineered for competition OR sealed must be presented for final Technical Inspection on completion of competition.
8. At National Bitumen Championships an engine cannot be used by more than one competitor or in more than one class.
9. All motors must be fitted with solid sealing nuts appropriate for the respective type of engine unless specifically noted in the class regulations. A maximum of one nut must be used per stud. A sealing nut is an extended head, cylinder or exhaust nut that has a minimum 3 mm hole through one end that will allow the fitting of an engine seal/tag. The nut must not be able to turn or be removed once fitted with a seal.
 1. Engines with integral cylinder and head studs:
The two (2) sealing nuts must be adjacent and the 3mm holes must be above the head fins NOT to have a through hole.
 2. Engines with head studs independent of cylinder studs:
The two (2) sealing nuts must have the 3mm holes above the cylinder fins and be adjacent. One internal hex cylindrical cylinder nut (cylinder to crankcase) to be fitted on the drive side, NOT to have a through hole (for ease of checking).
 3. Water Cooled Engines:
Two (2) head studs to be replaced by sealing nuts with the exception of Rotax Max and JMax
10. Standard Method of Issue of Engine Seals/Tags.
 - a) All engines must have provision for sealing in accordance with rule **1.30.9**
 - b) AKA bar coded engine seals and chassis tags to be supplied, fitted and recorded by officials of the meeting prior to commencement of competition.
 - c) It is the competitors responsibility to check their engine seals and chassis tags for loss or damage prior to leaving the in grid / scales area after each event.
 - d) Competitor shall be deemed not to have fulfilled their duty to manage their seals / tags should there be a loss or damage to after leaving the in-grid / scales area after each event, or failure to produce the correct seals / tags when requested.
 - e) **Tails on plastic seals to be left at full length**

1.31 Bar Codes:

Competitors must ensure that their engine and chassis tag barcodes are legible at all times. Any damaged or unreadable barcodes must be reported to the scrutineers prior to leaving the in-grid / impound area.

1.32 Change of Tyres:

1. The first set of tyres must be marked and or recorded prior to commencement or completion of the first section of the event.
Additional tyre to be marked and or recorded as required, subject to Scrutineers' decision.
Additional tyres must be marked and recorded by Scrutineers before use. It is the competitor's responsibility to ensure his/her tyres are marked.
2. At any race meeting, a competitor is permitted to use one set of prescribed dry tyres AND only one set of prescribed wet weather tyres in any class, including all practice / carby sessions after the commencement of competition for their event.
For practice / carby sessions prior to commencement of competition for their event, competitors are permitted to use any wet or dry tyres prescribed for their class.
3. Competitors must use the prescribed dry weather tyres, unless the track conditions are declared wet by the Clerk of the Course and Chief Steward of the race meeting. Only then may competitors choose to use either the prescribed dry tyres or prescribed wet weather tyres. Clerk of the Course and Chief Steward may also declare the track dry if and when weather conditions change.
Track conditions will be declared wet from when it appears that rain is imminent. A complaint/ appeal cannot be lodged against this action.
 - (a) Kart set up restrictions apply, refer side pod rule R25.02(vii) and diagram refer E-E.
 - (b) The mixing of dry and wet weather tyres on a kart during competition is not permitted. (with the exception of speedway karting)
4. One (1) damaged or worn out tyre (front or rear) of both the prescribed dry and wet weather tyres per event may be replaced with the consent of the scrutineer, who will impound the replaced tyre.
5. Damaged or worn out tyres (by way of force majeure) must be reported to and be inspected by the Chief Scrutineer prior to the kart leaving the grid/impound area. Replacement(s) will be at the competitors cost. Drivers receiving a replacement(s) will be required to start at the rear of the grid in their next competition, the only exceptions to this is a tyre with a manufacturing defect (as approved by the tyre representative and/or the Chief Scrutineer) and/or the competitor electing to use an approved used tyre.
6. For National and State Championships and all major events where tyre pooling is in force, drivers receiving a replacement(s) will be required to start at the rear of the grid in their next competition. The only exception to this is a tyre with a manufacturing defect (as approved by the tyre representative and/or the Chief Scrutineer).

1.33 Consumption of Alcohol/Drugs:

1. Consumption of alcoholic beverages in the paddock, Parc Ferme or any other portion of the competition venue under the control of the officials is expressly forbidden until all practice or competition activity is concluded for each day.

2. Any driver or crew member who is considered to have consumed any alcoholic beverage on the day of the event or practice shall not be permitted to participate.
3. Other than with the specific permission of a doctor, in writing and available for scrutiny, the use or consumption by any driver or crew member of any medication, or item, known or expected to have a stimulant, depressant, sedative or tranquillising effect is prohibited for a period of 24 hours prior to the commencement of any competition.
4. A driver, Pit crew or official who, in the opinion of the Stewards, is affected by alcohol, medication, drugs or any other cause shall be excluded from the meeting. The minimum penalty for unauthorised use of medication or other item is exclusion from the competition.
5. An appeal against this decision does not suspend the penalty of exclusion.

1.34 Alcohol and Drug Testing:

The AKA has adopted the Australian Sports Commissions policy on Drugs in Sport, which is in accordance with the FIA regulations. The IOC list of substances applies. Alcohol and marijuana are also prohibited. Refer www.karting.net.au

As a condition of entry a driver may be tested at any time for the consumption of alcohol or illegal substances.

The AKA recommends that Breathalyser Units be digital and self-calibrating.

Breathalyser Testing Procedure and Timetable:

Testing as per instructions with the Breathalyser Unit.

If positive (excess of 0.02 mg/100ml) then

- (a) record the reading and time of test
- (b) chaperone the person until a further test can be taken twenty (20) minutes after the first test
- (c) record the second result and time of test If both tests are positive (in excess of 0.02 mg/100ml) then proceed with a complaint.

CHAPTER 2

FEES

The fees payable to the AKA shall be as follows or as may be announced by the NKC from time to time.

(All fees are inclusive of 10% GST where applicable)

| | | |
|------|---|--|
| 2.01 | National Sprint (Bitumen) Championship Permit: (ii) 2011 – WA (iii) 2012 – NT | \$4400.00 plus \$65.00 per entrant \$4400.00 plus \$65.00 per entrant |
| 2.02 | National Dirt Championship Permit 2011 | \$300.00 per event |
| 2.03 | Australian Championship for CIK Classes Permit | \$1500.00 per event |
| 2.04 | State Sprint (Bitumen) Championship Permit: 2011 | \$500.00 plus \$10.00 per entry |
| 2.05 | State Dirt Championship Permit: 2011 | \$150.00 |
| 2.06 | 2011 Standalone National Championship | \$1100.00 |
| 2.07 | Temporary Circuit Permit | \$550.00 |
| 2.08 | Track Development – National all Events | \$2.00 per entry (no gst) |

LICENCES

| | | |
|------|--|-------------|
| 2.09 | AKA Licence (inc Insurance Component) | refer State |
| 2.10 | International Sprintkart Licence (inc Insurance) | \$150.00 |
| 2.11 | International Sprintkart Licence Upgrade | \$75.00 |
| 2.12 | New Licence (New Driver Levy) | \$20.00 |
| 2.13 | Trans Tasman Visa / International Visa | \$45.00 |

JUDICIARY

| | | |
|------|---|---|
| 2.14 | Complaints: From any Competition | \$55.00 |
| 2.15 | General Appeal | \$550.00 |
| 2.16 | Appeals: To AKAC (Aust Karting Appeals Court) | \$1100.00 for an appeal in writing \$2200.00 for an appeal in person |
| 2.17 | Appeals to AMSAC | \$6,600.00 |

EQUIPMENT

Fees applicable for Homologation/Registration and 3 year reviews of all registered equipment are available from the National Office Administration or refer to Chapter 21.



KART OWNERS

Why not talk to us about a **brand new insurance policy** designed especially for AKA licence holders & competitors. *Winning Solution for Karting Enthusiasts*

Broadest cover for your custom-made trailer, kart & spares.

Some highlights are: -

- * Accidental Damage.
- * Transit Risks
- * Static Risks
- * Comprehensive cover on the Trailer
- * Package Includes Trailer Liability

KART SHOP OWNERS

We will provide specialist advice and insurance covers for:

- * Contents, Stock of karts & parts.
- * Public & Products liability.
- * Burglary
- * Consequential Loss

WE ARE THE SOLUTION!

CALL US NOW FOR A QUOTATION.

TRANS-WEST INSURANCE BROKERS PTY LTD

79 BATHURST ST LIVERPOOL

PHONE: 02 9601 7166 FAX: 02 9821 2010

E-MAIL: mail@transwest.com.au

AFS Licence No: 230126

ABN: 90 001 996 489

APPOINTED INSURANCE BROKERS TO THE AKA

CHAPTER 3

INSURANCES

IMPORTANT NOTE

The information in this Chapter is a summary of the policies maintained by the AKA. Reference should be made to the policy documents for specific details of coverage, terms and conditions. The terms and conditions of the policies will prevail.

PUBLIC and PRODUCTS LIABILITY (Indemnity: 50 Million)

PROFESSIONAL LIABILITY (Indemnity: 1 Million any one period of insurance)

3.01 Premium: The premium for this Policy is paid by the AKA.

3.02 The Policy covers (as Insureds):

- the AKA and all affiliated and associated clubs, including their
- officials, officers, committees, volunteers, employees
- licence holders / members, competitors
- race track owners, land owners and lessees of property

against claims made by third parties for negligence arising out of the stated business activities of the Insured.

3.03 The Policy insures the above against claims which they are legally liable to pay arising out of:

- personal injury
- property damage
- damage to property in the physical or legal control of the insured – Limit \$25,000.
- advertising liability (as defined in the policy).

3.04 The Policy covers:

- motor sport activities permitted by the AKA
- the sale, supply, handling or distribution of goods, products and merchandise by the AKA
- committee and club meetings, social gatherings, fund raising activities, working bees, etc. officially organised by an AKA club, and within the definition of activities described under the policy.

3.05 The Policy Deductible:

- Public/Products Liability – \$15,000 for any one claim
- Professional Liability – \$15,000 for any one claim.

3.06 What to do if you become aware of an injury or damage likely to give rise to a claim under the policy.

Notify your State Secretary as soon as possible and complete an SLE Motor Sport Case Report Form to be sent to Trans-West Insurance Brokers.

- Give full details of the circumstances.
- Do not admit responsibility for any injury/damage.
- Provide the names and address of witnesses.
- Make or obtain a sketch plan wherever possible.

ASSOCIATION LIABILITY (Indemnity: 5 Million)

3.07 Premium: The premium for this Policy is paid by the AKA.

3.08 The Policy covers:

- the AKA, State bodies & affiliated clubs
- their officers, executives, directors, secretaries, employees (incl. paid or unpaid volunteers)

3.09 The Policy Deductible:

- \$1,000 (Professional Indemnity, Office Bearers and Association Reimbursement sections only)

3.10 What to do if you become aware of an injury or damage likely to give rise to a claim under the policy. Notify your State Secretary as soon as possible and ask for Trans-West Insurance Brokers to be advised.

- Give full details of the circumstances
- Do not admit responsibility for any incident or potential claim
- Provide the names and address of witnesses

PERSONAL ACCIDENT INSURANCE (Compulsory)

3.11 Premium: The premium for this Policy is paid by the AKA.

3.12 The Policy applies to:

AKA Officials, drivers, pit crews and voluntary workers (subject to age limitations).

3.13 What are they covered against?

Bodily injury resulting from an accident. (As per policy terms and conditions)

3.14 When are they covered?

Bodily injury which occurs whilst they are engaged in the following activities:

- (i) engaging in official kart club activities including championship titles, club or State representative titles/activities;
- (ii) engaging in official organised training or practice for activities as described in (i) above;
- (iii) travelling directly between the activities in (i) or (ii) above, and their residence or place of employment or the premises of the Insured;
- (iv) engaging in administrative or organised social activities of the AKA.
- (v) staying away from their home district during a tour for the purpose of participating in such activities;

3.15 When must the claim be made?

Claims must reach our insurers in Sydney within twenty-one (21) days of the injury.

3.16 How do you get a claim form?

Claim forms are available from your State Secretary.

3.17 What information must be provided?

- 1 The form must be fully completed.
- 2 You must provide evidence that you are employed and your income.
- 3 If self-employed, provide a statutory declaration from your accountant proving your income.
- 4 The doctor's certificate should show the anticipated time off work, if any.

3.18 Outline of Benefits

Injury Causing:

- (a) Accidental Death
- (b) Loss of Limb(s) Eyes
- (c) Permanent Paraplegia and Quadriplegia
- (d) Temporary Total Disablement
- (e) Temporary Partial Disablement

Income Earning Drivers, Pit Crews (aged 16 or over):

Benefits:

- (a) Up to a maximum of \$75,000
- (b) Up to a maximum of \$75,000
- (c) Up to a maximum of \$75,000
- (d) 85% of weekly income or \$500 whichever is the lesser but not less than \$100 per week.
(Payable up to 104 weeks, but excluding the first fourteen (14) days).
- (e) 40% of weekly income or \$200 whichever is the lesser but not less than \$40 per week.
(Payable up to 104 weeks, but excluding the first fourteen (14) days).

Non-Income Earning Drivers, Pit Crews (aged 16 or over):

Benefits:

- (a) Up to a maximum of \$75,000
- (b) Up to a maximum of \$75,000
- (c) Up to a maximum of \$75,000
- (d) \$200 per week with respects to 'Domestic Home Help' (Limit fifty two (52) weeks)
- (e) \$80 per week with respects to 'Domestic Home Help' (Limit fifty two (52) weeks)

NOTE:

Drivers, Pit Crews aged over 70 years who require cover must be referred to Trans-West Insurance Brokers Pty Ltd for insurer approval.

The Capital Benefit (a), (b), (c) above is reduced to \$10,000.

Drivers, Pit Crews aged 7 to 16 Years:

Injury Causing:

- (a) Accidental Death
- (b) Loss of Limb(s) Eyes
- (c) Permanent Paraplegia and Quadriplegia

Benefits:

- (a) Up to a maximum of \$10,000
- (b) Up to a maximum of \$75,000
- (c) Up to a maximum of \$75,000

Officials, Pit Crews & Volunteers (aged 16 or over):

Benefits:

As per the Earning Income Drivers/Non-Income Earning Drivers, Pit Crews (aged 16 or over):
However, the Excess / Deferral Period is Nil.

- 3.19 Non Medicare Medical Expenses:**
Up to 85% of eligible expenses, after reimbursement from a recognised private health fund, to a maximum of \$5,000. Excess of \$100 applies if the claimant is not in a Private Health Fund.
- 3.20 Ambulance Costs:**
Up to \$5,000 any one insured person.
- 3.21 Confinement to Bed (Non-Income Earners):**
Up to \$200 per week for up to fifty-two (52) weeks.
- 3.22 Rehabilitation Costs (Home and vehicle modification costs):**
Up to \$5,000 for any one insured person.
- 3.23 Funeral Benefits:**
Up to \$3,000 any one insured person.
- 3.24 Student Home Tutorial Costs: (Full Time Students not more than 20 Years of age)**
Up to \$200 per week for fifty two (52) weeks maximum.
- 3.25 Qualified First Aid:**
Qualified first aid personnel must be in attendance at all official AKA race meetings.
- 3.26 Ambulance Attendance at Race Meetings:**
The Insurer and the AKA recommend that an ambulance is in attendance at all official AKA race meetings. (ie. St. John Ambulance or equivalent, according to local law.)
- 3.27 Civil Ambulance Membership:**
The Insurer and the AKA recommend that all karters should have civil ambulance membership.

**At Trans-West we understand the need for
Personal/Professional Protection**

With our dedicated teams for:

BUSINESS INSURANCE

(Designed to fit your needs)

EMPLOYERS

(Workers Compensation • keeping costs under control)

PROFESSIONAL INDEMNITY

(Finding the right cover and cost combination)

BUILDERS

(Home Warranty and Construction Insurance issues)

LANDLORDS INSURANCE

(Taking the worry out of your investment properties)

We are the best people to protect your assets and investments

TRANS-WEST INSURANCE BROKERS PTY LTD

79 BATHURST ST LIVERPOOL
PHONE: 02 9601 7166 FAX: 02 9821 2010
E-MAIL: mail@transwest.com.au
AFS Licence No: 230126
ABN: 90 001 996 489

INSURANCE BROKERS AND RISK MANAGERS



CHAPTER 4

OFFICIALS AND DUTIES

General Duties of Officials

It will be the general duty of all officials, irrespective of the duties assigned to them and whether appointed by the AKA, the SKC or the promoters of any meeting, to act honestly and in good faith and in accordance with these regulations and rules and the general interests of the sport of Karting.

In particular an AKA Official will be bound by the provision of chapter five insofar as that chapter may relate to offences that may be capable of being committed by an official.

No AKA Official is to make any comment to or on any form of electronic media or otherwise, pertaining to any issue arising from a race meeting.

4.01 List of Officials:

- (a) The staff of officials whose duty it shall be to direct and control competitions may include: -
- The Stewards of the Meeting
 - The Chief Observer
 - The Clerk of Course (or Director) and Assistants
 - The Race Prosecutor
 - The **Race / Competition** Secretary of the Meeting
 - The **Chief Timing Officer**
 - The Chief Scrutineer and Scrutineers
 - The Technical Inspectors
 - The Fuel Tester
 - The Tyre Tester
 - The Scale Marshals
 - The Flag Marshals
 - The Pit Marshals
 - The Starter
 - The Grid Marshals
 - The Observers
 - The Lap Scorers
 - The Noise Control Marshal
 - Officials Secretary (Steward's Secretary)
- (b) They shall be termed "officials" and must be a minimum 18 years of age. All Officials, except for Stewards and Technical Inspectors, may have assistants to whom any of their duties may be delegated.
- (c) **All States shall be responsible to conduct training schools for Clerk of Course / Steward's and Scrutineers / Technical Inspectors. All AKA Licenced Officials must satisfactorily complete an Officials Training School annually, either "on line" or in person, in order to retain their AKA Official's accreditation. Officials residing close to State borders may attend a training school in either state.**
- (d) **All State Karting Councils must appoint a State Officials Coordinator. State Officials Coordinators can officiate as a Clerk of Course / Steward in their own State.**
- (e) State Karting Councils, at their discretion, may nominate additional official positions e.g. announcer, race controller and / or Clerk of the Course Prosecutor to any race meetings. These positions must be included in the approved supplementary regulations for the race meeting.

4.02 Right of Supervision:

- (a) In addition to the Officials above, the AKA may confer on persons specially qualified, the right to observe any person or body of people promoting or organising or taking part in the promotion or organisation of any competition within the territory of the AKA or any person acting as an official, competitor or driver, or any holder of a licence issued by the AKA in any competition held in any country whatsoever under the Code.
- (b) Whether so named in the relevant documents or not, the members, for the time being, of the NKC or Executives of State Councils shall, ex officio, be observers at all meetings organised under the Permit of the AKA, and shall, on production of their Badge of Office, be accorded free access to all parts of the course at such meetings, and shall have the power to take decisions and issue instructions, with regard to safety and orderly conduct of the meeting.

4.03 Essential Officials:

- a) At a meeting there shall be at least two licensed Stewards of the Meeting. National Office to supply all grades of Stewards with a current AKA Manual.
- b) Only Stewards may officiate as Stewards at a race meeting except as allowed for in Rule 4.09(m)
- c) Clerk of the Course or Director, and in the case of speed competitions decided wholly or partially by time, one (1) or more timekeepers shall be appointed as essential officials at the meeting.

4.04 Nomination of Officials:

The Stewards of the Meeting and the Clerk of the Course will be nominated by the SKC and be responsible to the AKA.

All Officials, other than the Stewards of the Meeting and Clerk of the Course, shall be appointed by the Promoters and approved by the SKC and the AKA.

At any International Open Meeting held within the territory of the AKA, and at all meetings in which there is any event carrying a national title, the Stewards and Clerk of the Course shall be appointed by the SKC or AKA, and approved by the AKA.

4.05 Plurality of Duties:

At State and National Championships plurality of duties of key officials is not permitted. At club meetings it is strongly recommended plurality of duties is not undertaken by any official. (At no time may a steward perform more than one duty).

4.06 Separation of Duties:

- (a) An Official shall not, at any meeting, perform any duties other than those which are clearly attached to his/her appointment or appointments. He/she shall not be eligible to compete in any competition at a meeting at which he/she is acting as an Official, except as covered in Rule 4.06(c).
- (b) A competitor may be a flag marshal or may assist an official, except the Clerk of the Course or Steward, at a non-championship event provided it is announced at the driver's briefing and the competitor is not responsible for any official documentation, except as covered in Rule 4.06(c).
- (c) At club level race meetings, where there are less than 50 legitimate entries, a competitor may act as any Official except Chief Steward or Clerk of the Course, providing they possess the appropriate accreditation.

4.07 Remuneration of Officials:

All officials at any AKA Permitted race meeting shall act in an honorary capacity. Appointed officials may be reimbursed for their expenses by the organisers/promoters of the meeting. The AKA shall cover travel and accommodation expenses for appointed Interstate Steward/s for National Sprint Championships (bitumen), and travel expenses for appointed Interstate Steward for State Sprint Championships (bitumen). All refreshments, breakfasts and lunches as required at the track are the responsibility of the promoting club. Evening meal expenses are the responsibility of the promoting club with a recommended \$40 limit per night. Other Officials may be remunerated for their services by the organisers of the meeting.

4.08 Appointment of Chief Steward:

- (a) When the NKC has appointed one or more of the Stewards of the Meeting, such Steward, or if more than one have been appointed by the NKC, the Steward appointed from that group shall act as the Chief Steward of the Meeting.
- (b) In the case of equality of votes amongst all of the Stewards of the Meeting, the Chief Steward shall have a casting vote. If the judgement cannot be given immediately after the hearing of the parties, they must be advised of the time and place at which the decision will be given.
- (c) The Stewards/Clerk of Course of the Meeting may use an Officials secretary to complete paperwork at a race meeting.

4.09 Powers of the Stewards of the Meeting:

The Stewards of the Meeting shall have general power and authority to enforce compliance with the Code, these Rules, the Supplementary Regulations, the Programme, and the Instructions to Drivers (if any), and to adjudicate upon any dispute or complaint arising during the meeting subject to the rights of appeal provided by these Rules and in particular shall have power in accordance with these Rules to:

- (a) Keep order in conjunction with such military and police authorities as have undertaken the policing of the meeting and who are especially responsible for public safety.
- (b) Decide what penalty to inflict for a breach of these Rules.
- (c) Modify the Supplementary Regulations in exceptional circumstances.
- (d) Alter the composition of or consolidate heats.
- (e) Authorise a run-off in the case of dead-heats.
- (f) Accept a correction made by a Judge.
- (g) Amend placing's and awards as laid down in Rule 4.17(f) and Rule 6.01.
- (h) Prohibit from competing any driver who, or any kart which they consider to be dangerous, or is reported as such by the Clerk of the Course or a Scrutineer.
- (i) Exclude from one or more competitions or for the duration of the meeting any entrant or driver whom they consider to be or who is reported to them by the Clerk of the Course or Director or Promoters, to be ineligible to take part therein or whom they consider guilty of misbehaviour or unfair practice.
- (j) Exclude from the course and its precincts any competitor or driver who refuses to obey the order of a responsible Official.
- (k) Postpone or alter the conditions of a competition for reasons of safety and "force majeure."
- (l) Modify the position of the starting area or finishing line, or alter the programme at the request of the Clerk of the Course or the Promoters where necessary to ensure reasonable safety for drivers and spectators.

- (m) Appoint a temporary substitute or substitutes to replace any Steward or Stewards not able to perform his/her duties. Such power shall be exercised by the remaining Steward or Stewards and shall be used to ensure that there are always at least TWO Stewards of a Meeting.
- (n) View Cinematographic, photographic or similar apparatus to facilitate the Stewards decision.

4.10 The Stewards of Meeting to Report:

As soon as practicable, but no later than five days after the conclusion of a Meeting, the Stewards of the Meeting shall, with the help of information provided by the Clerk of the Course, or Director, compile, sign and send to the AKA a report giving the results of each competition together with particulars of all complaints lodged, action taken thereon, penalties imposed, together with any recommendation in respect of such cases. The report shall also contain the Stewards' general comments on the organisation of the Meeting and the exercise of their own powers in relation thereto, and any other observations as to the conduct of the Meeting which they consider should be made to the AKA as the authority under whose permit the Meeting was held. There shall be submitted with the report any notices of intention to appeal and appeal fees received in accordance with these Rules.

4.11 Powers of the AKA Following the Stewards' Report:

- (a) If it appears to the AKA from the Stewards' Report or otherwise that a mistake has been made during competition or that the results of a competition have been improperly or incorrectly made out, the AKA shall be entitled to inquire into the matter, and, after giving the interested parties an opportunity to be heard, make such order as it deems proper, even though no complaint or appeal may be outstanding. Provided that no such inquiry shall be ordered after the expiration of 60 days after the publication of the results.
- (b) A copy of the Stewards' Report from all National Championships will be circulated to the States after completion of Hearing of Complaints, Appeals, etc.

4.12 Duties of the Clerk of Course or Director:

All Clerks of Course must attend an Officials Training School once a year.

In the case of a meeting comprising several competitions there may be a different Clerk of Course or Director for each competition. The Clerk of Course is responsible for the general conduct of the meeting in accordance with the Supplementary Regulations, Programme and Organising Permit, and, in particular, he/she shall:

- (a) Ascertain whether all Officials are at their posts, and report the absence of any of them to the Stewards of the Meeting.
- (b) Ensure that all Officials are provided with the information and equipment necessary for carrying out their duties.
- (c) Before each race meeting the drivers of the ambulance and pick-up vehicle/s are to be instructed not to move their vehicles inside the race track area whilst Karts are in motion.
- (d) Control competitors and their karts and prevent any ineligible competitor, driver or kart from taking part.
- (e) Ensure that each kart and (where appropriate) each competitor carries the proper identification marking in accordance with the programme.
- (f) Ensure that the correct driver is in each kart and marshal the kart as necessary.
- (g) Send the karts to the start in their right order and, if necessary, start them.
- (h) Convey to the Stewards of the Meeting any proposal to modify the programme or any report that deals with the misbehaviour of, or breach of rule by, a competitor or driver.

- (i) Receive complaints from competitors or drivers and immediately transmit them to the Stewards of the Meeting. Collect the reports of the Timekeepers, Scrutineers, Assistant Scrutineers and Observers together with such official information as may be necessary for the determination of the results.
- (j) Prepare a written statement of the information necessary to enable the Stewards of the Meeting to complete their report.

4.13 Duties of the Race / Competition Secretary of the Meeting:

The Secretary of the Meeting shall be responsible for the organisation of the meeting as regards all material and notices required in connection therewith. He/she shall satisfy himself that the various officials are acquainted with their duties and are furnished with the necessary equipment and issue armbands or a form of identification designating their status at the meeting. If necessary he/she shall assist the Clerk of the Course or Director in the preparation of the information required for the Stewards' Report. He/she shall send to the AKA and make available via electronic means, within 72 hours of the end of the meeting, a dated list of the provisional results of a State or National Championship.

4.14 Duties of the Chief Timing Officer:

The principal duties of Timekeepers shall be:

- (a) At the commencement of the Meeting to report personally to the Clerk of the Course or Director for instructions.
- (b) To start speed competitions if so instructed by the Clerk of the Course. In the case of a handicap competition, where the handicap is applied at the start, the starter shall be a timekeeper.
- (c) In races and speed events, and such other events as may be required by the AKA, to use only such apparatus for timing attempts at records where it is necessary to take times within one hundredth of a second.
- (d) To register such times as are appropriate, having regard to the conditions of the competition, or are required by the Clerk of the Course or Director.
- (e) To prepare and sign their reports relating to the timing which is their individual responsibility, and to send them, with all necessary supporting documents, in the case of a meeting to the Clerk of the Course or Director and in the case of an attempt at record or test to the AKA.
- (f) To send on request their original time sheets either to the Stewards of the Meeting or to the AKA.
- (g) To communicate any times or results only to the Stewards of the Meeting and the Clerk of the Course or in accordance with their instructions.
- (h) **Chief Timing Officer** shall be Judge of Fact as to confirm and register times as are appropriate.

4.15 Duties of Chief Scrutineer, Scrutineers and Technical Inspector:

The Scrutineers are generally responsible for ensuring compliance with Chapter 12. – Scrutineering and Technical Inspection.

The functions of Chief Scrutineer, Scrutineers, Technical Inspector, Fuel Tester and Tyre Tester may be combined at the discretion of the Chief Scrutineer, who, in particular shall:–

- (a) Make inspections before a meeting at the request of the Promoters,
- (b) At the commencement of a meeting report personally to the Clerk of the Course or Director.
- (c) Make inspections during, or if required, after a meeting.
- (d) Use only such measuring instruments as may be specified or approved by the AKA or as deemed necessary by the Technical Inspector / Scrutineer to determine compliance.

- (e) Communicate official information only to the AKA, the Promoters, the Stewards of the meeting and the Clerk of the Course or Director.
- (f) Prepare and sign the reports of their inspections and forward them to the Stewards of the meeting or the Clerk of Course as may be appropriate.

4.16 Duties of Observers, Flag Marshals and Starters:

- (a) The Observers shall occupy posts along the course assigned to them by the Stewards of the Meeting, the Promoters, or the Clerk of the Course or Director. As soon as the meeting commences each observer is under the orders of the Clerk of the Course, to whom he/she shall immediately report by any means at his/her disposal all incidents and accidents which occur on the section of track for which he/she is responsible.
- (b) At the end of each competition all Observers must give to the Clerk of the Course or Director a written report of all incidents noticed by them.
- (c) During a competition Observers/Announcers may be required to inform a specified official of the order in which competitors pass their post, lap by lap in case of a circuit competition.
- (d) Flag Marshals are marshals appointed to give signals by flags to the competitors in accordance with the signals laid down in these Rules. Only professional or fully experienced persons to officiate at State and National Championships. They may also act as Observers.
- (e) Officials under the age of 18 years are not permitted to act as Flag Marshals at any Race Meeting.

4.17 Duties of Judges:

- (a) The Judges of Fact at each race meeting are the Starter, Chief Lap Scorer, Chief Timing Officer, Weigh in Marshal, GC Analyst, Grid Marshall and Noise Control Marshal and Chief Scrutineer.
- (b) Other Judges of Fact (if any) will be specified in the Supplementary Regulations.
- (c) The duty of a Judge of Fact is to decide when or whether a kart has touched or passed a given line, or upon some other fact of the same type laid down in these regulations or the Supplementary Regulations.
- (d) A complaint may not be made against the decision of a judge, which shall be accepted as final unless corrected as herein after provided. The finding, though final as regards the fact decided, shall not constitute a statement of results because it will not have taken into account the conditions under which the karts have completed the course.
- (e) Cinematographic, photographic or similar apparatus may be used to facilitate a Judge's decision.
- (f) A mistake by a judge may be corrected by him/her with the approval of the Stewards of the meeting.

4.18 Duties of the Starter:

- (a) To signal the start of competition in a manner that is fair for all competitors.
- (b) To signal competitors with flags and boards as required by these Rules.
- (c) To report to the Stewards, and/or Clerk of Course any competitor whose conduct, before the commencement of the race, is not satisfactory. (Refer also Rule 16.09)
- (d) The Starter shall be Judge of Fact and will determine competitors who are in breach of Rule 16.09 (i) (iv) (v) (vi) (vii).

4.19 Duties of the Pit/Paddock Marshals:

The Pit/Paddock Marshal shall be responsible for the general organisation, lay-out and control of the pit/paddock area.

4.20 Duties of the Grid Marshals:

The Grid Marshals shall be responsible for the marshalling of the karts in their correct grid positions, controlling karts until such time as they are placed in the hands of the Starter and at all times to co-operate with the Pit/Paddock Marshal.

4.21 Duties of Scale Marshals:

- (a) The Scale Marshals shall be responsible for weighing karts/drivers in accordance with these regulations
- (b) Competitors must weigh to the scales of the day. It is recommended that the scale marshal has a set of test weights that will enable the accuracy of the scales to be verified during competition.
- (c) Should a competitor fail their first test they may request one (1) additional test.
- (d) The Scale Marshal shall be Judge of Fact as to measure the weight of any kart and driver at the completion of any section of any event.

4.22 Duties of Noise Control Marshal:

- (a) The Noise Control Marshall shall be Judge of Fact as to the noise level recorded by any individual kart.
- (b) The Noise Control Marshall shall be responsible for monitoring and reports on noise levels of all karts in accordance with these regulations.

4.23 Duties of Lapscorer:

- (a) The Chief Lapscorer shall be Judge of Fact as to the number of laps completed and the race order of any section of any event.
- (b) Lapscorers shall record the order that karts cross the line, each lap and shall tally points and record all places in each event.
- (c) The final placing of every kart should then be placed on a master sheet, from which the grid positions for the next heat of that class can be obtained.
- (d) The grid positions should then be posted on the notice board, as soon as possible after each heat, to assist the Pit and Grid Marshals.

4.24 Duties of a Race Prosecutor:

Each State Association may appoint one or more Race Prosecutors. The Race Prosecutor's principal role is to act on the instructions of the Officials at an AKA sanctioned race meeting and appear at a Steward's hearing on behalf of Officials of the meeting, as their advocate. Instructions are to be provided by either the Clerk of the Course, the Race Secretary or the Chief Scrutineer / Technical Inspector.

Refer to policy document AKAPD01, available from the National Office or at www.karting.net.au.

4.25 Other Official Positions:

The preceding rules outline the type and duties of Officials who direct and control competitions at AKA sanctioned race meetings.

The following rules outline the type and duties of Officials who may be required for the AKA's judicial process to function.

- a) **State Prosecutor:** Each State Association may appoint one or more State Prosecutors. The State Prosecutors principal role is to act on the instructions of the State Association and appear on its behalf in Tribunals and Appeal Tribunals, as their advocate. Refer to policy document AKAPD02, available from the National Office or at www.karting.net.au.

- b) **State Tribunal Registrar:** Each State Association may appoint a State Tribunal Registrar. The principal role of a State Tribunal Registrar is to ensure that the State Tribunals function in an efficient and proper manner and that the Tribunal rules are complied with. The Office of State Tribunal Registrar ("STR") is an administrative position, not a judicial position. Refer to policy document AKAPD03, available from the National Office or at www.karting.net.au.

CHAPTER 5

GENERAL OFFENCES

5.01 A person subject to these rules must not:

- (a) Use foul language or threatening language;
- (b) Do any act or speak in an intimidating manner;
- (c) Assault, strike, touch or move or otherwise apply force of any kind to the person of another or attempt to do so, except as the circumstances may justify or excuse such action.
- (d) Speak words or act in a manner which in the opinion of the officials, is likely to bring the Sport into disrepute;
- (e) Do any act which in the opinion of the officials is likely to bring the Sport into disrepute;
- (f) Bribe or attempt to bribe another person or accept a bribe;
- (g) Compete whilst not currently licenced (minimum penalty of three years suspension);
- (h) Conspire to enable an ineligible person to enter a race or compete in a race;
- (i) Act in any way dishonestly;
- (j) Act in any way which is to the prejudice of karting;
- (k) Remove or be in the possession of, without permission, an official notice or list of competitor's times or results;
- (l) Make a false statement to any official or a tribunal member or member of the AMSAC;
- (m) Make a frivolous complaint or appeal;
- (n) Make a complaint or appeal for an improper purpose;
- (o) Use an engine, part or accessory which, in the opinion of the officials, is illegal under these rules or has been illegally modified;
- (p) Take part in a competition in breach of the regulations;
- (q) Use a fuel, lubricant or other substance not permitted by these regulations;
- (r) Fail to comply with the weight specifications set out in these regulations;
- (s) Fail or refuse to present as directed, or prevent;
 - (i) an inspection or test of any part of a kart
 - (ii) an inspection or test of any part of a driver's clothing or equipment
 - (iii) the weighing of a kart, accessory or driver
 - (iv) an inspection or test of any fuel, lubricant or other substance in the possession of the driver or the Parc Ferme crew or under the control of any of them.
- (t) Fail to attend a Tribunal or inquiry when required by the State Tribunal Registrar or the Tribunal;
- (u) Fail to give evidence as a witness before a tribunal or inquiry when called, except to avoid self-incrimination;
- (v) Fail to pay to the AKA or an SKC within one month of its falling due any amount;
- (w) Fail to obey a proper order of an official of a meeting or the SKC or AKA or of a Tribunal or Court;
- (x) Remove a seal or mark without the consent of the official who placed it in position;
- (y) Remove a kart impounded for testing without the express permission of the proper official.

- 5.02 A person found to have committed an offence against Rule 5.01 (o) will be excluded from the section of the event to which the offence relates. This offence will be subject to a stewards hearing and possible further penalty.

- 5.03** 1. A person found to have committed an offence against Rule 5.01(q) shall be automatically excluded from the section of the competition to which the offence relates. (Refer Chapter 22 and Rule 25.18(c).
2. A person found to have committed an offence against Rule 5.01 (r) shall be automatically excluded from the section of the competition to which the offence relates, EXCEPT during timed qualifying sessions when rule 16.05(e) applies.
- 5.04** 1. Any competitor who breaches Rule 16.09 starting of a race may face action taken by the issue of a Penalty Notification Form which will be issued without a Officials Hearing and signed by at least one Steward and one other Steward, Clerk of the Course or Starter. A complaint / appeal cannot be lodged against this action.
2. Any competitor who does not comply with weights Rule 5.01 (r) will have action taken by the issue of a Penalty Notification Form which will be issued without a Officials' Hearing and signed by at least one Steward and one other Officials, Scale Marshal, or Clerk of the Course. A complaint / appeal cannot be lodged against this action.
3. Any competitor who does not comply with Noise Rule 24.2 will have action taken by the issue of a Penalty Notification Form which will be issued without an Official's hearing and signed by at least one (1) Steward and one (1) other official, Noise Control Marshal or Clerk of the Course. A complaint / appeal cannot be lodged against this action.
- 5.05 These regulations apply to anything done or not done:**
- (a) on any land occupied or used by any kart club
 - (b) at any temporary circuit
 - (c) at any meeting of any kart club, karting council, karting tribunal or motor sport appeal court
 - (d) in connection with any karting competition.
- 5.06** In proceedings before a karting tribunal or the AMSAC, any reference in a rule to the opinion of the officials must be taken as a reference to the opinion of that tribunal or the court, as the case may be.

CHAPTER 6

PENALTIES

6.01 Types of Penalties: (during a race meeting)

The Stewards of the meeting may impose a penalty consisting of ONE or More of the following:

1. A fine (up to \$1,000.00)
2. Revise finishing order
3. Revise grid position
4. Time penalty
5. Place Penalty
6. Points Penalty
7. Exclusion from that section of the event
8. Exclusion from the event
9. Exclusion from the meeting
10. Suspension (up to 6 months)

6.02 Explanation of Penalties:

Any penalty imposed on a driver must be noted on the competitors "electronic licence page" of the AKA Licence System.

If any penalty is varied by a Tribunal or Court, the notation on the competitors "electronic licence page" must then be altered by the relevant State Secretary after notification from the Tribunal or the Registrar.

1. A fine (up to \$1,000.00)

Fines are imposed for a breach of rule/s where no other listed penalties are deemed appropriate.

When a fine has been imposed as a result of a Stewards hearing, the competitors licence is automatically suspended until one of the following conditions is met:

- (a) fines of \$250.00 or less must be paid within 1 hour of the Stewards decision.
- (b) for fines greater than \$250.00, a minimum of \$250.00 must be paid within 1 hour of the Stewards decision, with the balance paid within 14 days of the date of the decision. Competitors may continue to compete only after payment of the minimum amount (\$250.00), prior to the balance being paid.

If the licence holder does not comply with the time limits for payment of a fine, the licence is automatically suspended for a period of two days for every day between the date notified as the date by which the fine/fee was due to be paid and the date on which all directions in the notification have been complied with.

2. Revise finishing order.

A revision of the finishing order of a race may be imposed when the Stewards deem a competitor has gained an unfair advantage, or unfairly disadvantaged other competitor/s. Generally used when the finishing order determines a grid position or placing with no points attached (pre-final or final only counts). Succeeding competitors affected by the revised finishing order will receive the entitlements associated with their revised placing. When circumstances permit, revision of the finishing order of a race may also permit the reinstatement of unfairly disadvantaged competitors.

- There are many and varied scenarios, both positive and negative, where this rule can be, or should not be applied.
- It is the duty of all AKA Licenced Officials to only use this rule "when circumstances permit" or during the application of a penalty of revision of the finishing order of a race.

3. Revise grid position.

Generally only imposed for a starting infringement issued prior to the re-start of a race. Imposed by the Stewards / Starter using a penalty notification form.

4. Time penalty.

A time penalty may be imposed in any race where approved timing equipment is used to record timing / lap scoring recording. A time penalty, when added to the competitors total race time, may alter the original placings for that section of the event.

5. Place Penalty

A place penalty revises the finishing order of a race. All competitors affected by the revised placing will receive the relevant placing / points entitlements associated with their revised placing.

6. Points Penalty

A points penalty only changes the points allocated to the penalised competitors finishing position in the race. It does not affect the finishing positions or points allocation of any other competitors in the race.

7. Exclusion from that section of the event.

Excludes the competitor from any entitlements (points / placing) for that race only. Refer to Consequences of Exclusion, below.

Points / placing allocated will be the same as a disqualification (DSQ).

8. Exclusion from the event

Excludes the competitor from any further participation in any section of that event (class), and any entitlements already gained for the relevant class, for the entire race meeting. Refer to Consequences of Exclusion, below.

Competitor may still compete in other events (classes) at that meeting.

9. Exclusion from the meeting

(1) When a licence holder is excluded from a meeting,

(a) the penalty is applied immediately it is imposed and the licence holder cannot take any further part in that meeting.

(b) he competitor loses any points, placings or awards in all sections of events (classes) completed at that meeting before the penalty of exclusion was imposed. Refer to Consequences of Exclusion, below.

(c) the competitor forfeits any fees paid in respect of that meeting.

(2) An automatic exclusion does not prevent the imposition of any additional penalty (after the hearing of a complaint) for the same offence.

(3) A penalty of exclusion may be imposed by stewards who refer a matter to a Disciplinary Tribunal for further penalty. This does not prevent the tribunal from varying or imposing a further penalty.

10. Suspension (up to 6 months)

(1) When a licence holder has their licence suspended;

(a) the sentence of suspension is applied immediately it is imposed, subject to provisions relating to appeals as stated in Rule 8.11.

(b) the competitor loses any points, placings or awards in all sections of events (classes) completed at that meeting before the licence suspension was imposed.

(c) the competitor forfeits any fees paid in respect of that meeting.

(d) the Stewards may refer the matter to a Disciplinary Tribunal for further penalty. This does not prevent the tribunal from varying or imposing a further penalty.

- (2) A licence holder who is suspended cannot Practice, Race or act as an Official at any AKA licensed track during the period of their suspension.

Consequences of Exclusion or Suspension:

For the purposes of lap scoring / recording, when a competitor is excluded from a section of an event, excluded from an event, excluded from a meeting or suspended during a meeting, their relevant placings / points entitlements will be assumed by the relevant succeeding competitors with all subsequent placings / points adjusted accordingly.

6.03 Referral to a Disciplinary Tribunal :

The Stewards of a meeting may refer a matter / competitor to a SKC Disciplinary Tribunal when;

- there is good reason why the matter cannot be dealt with during the course of the race meeting.
- a competitor receives a third written warning (within a twelve month period) on their "electronic licence page" of the AKA Licence System. Refer to rule 6.04(5)
- The Stewards, after conviction, determine that a penalty is warranted which they are not authorised to impose. In that case, the written statement of the Stewards that the charge has been found proved shall be conclusive evidence of that fact. Refer to rule 9.02(a)(iv).
- The Stewards must also advise the competitor/s what penalty, if any, will be recommended to the Tribunal, but advise that the Tribunal may vary the penalty.
- There is no fee for officials of a race meeting who refer a matter to a Disciplinary Tribunal.

NOTE: Matters requiring referral to a Disciplinary Tribunal during the running of a State or National Championship must be referred direct to the AKAC (Australian Karting Appeal Court). except as per rule 7.18(a-f)

6.04 WARNING (NOT A PENALTY)

- Any competitors under the age of 18 years who are called before a Clerk of the Course or Steward for a verbal or written warning must be accompanied by a parent or adult guardian before being addressed by an AKA Official.

2. Verbal warning.

A verbal warning is given for a minor infringement that does not advantage or disadvantage any body, and which is normally caused by inexperience, lack of familiarity or an error of judgement, and is unlikely to be repeated.

A verbal warning cannot be given as a penalty as a result of a stewards hearing.

A verbal warning is not recorded on the competitors "electronic licence page" and does not appear on the Steward's Report for the meeting.

3. Written warning.

A written warning is given for an infringement that has not greatly advantaged or disadvantaged anybody, but is one the offender should have known better, and if a similar offence is repeated, it will result in a complaint.

A written warning cannot be given as a penalty as a result of a steward's hearing.

A written warning is recorded on the competitors "electronic licence page" and does appear on the Steward's report for the meeting.

- A steward may, if no complaint has been made concerning an incident, verbally warn a person subject to these rules, **and** make a notation to that effect on the person's "electronic licence page" of the AKA Licence System. The steward must first advise the person what offence the steward believes the person has committed and must give the person an opportunity to

provide an explanation. If a complaint is subsequently made concerning the incident which resulted in the warning, a hearing must be held. If a stewards' hearing is held, and the complaint proven, the notification of the warning on the person's "electronic licence page" of the AKA Licence System may be cancelled. If the complaint is dismissed the notation on the person's "electronic licence page" of the AKA Licence System must be cancelled.

5. A person who has three or more written warnings recorded on their "electronic licence page" of the AKA Licence System in a 12 month period will be required to show cause to a Disciplinary Tribunal why that person should not be penalised. A Tribunal must deal with the matter as a matter of penalty only, and must accept that the person has committed the offences which were the subject of the warnings.

SUGGESTED PENALTIES FOR NON CONFORMANCE OF AN ENGINE OR PART

| RULE | NON -CONFORMANCE | SUGGESTED PENALTY |
|-------------------|--------------------------------------|---|
| 26.01 | Engine failed CC test | Exclusion from meeting plus 1 month suspension |
| 5.01 (o) | Illegally machined part | Exclusion from meeting plus 3 months suspension |
| 5.01 (o) | Tampering of engine ports | Exclusion from meeting plus 6 months suspension |
| 5.01 (o) | Airbox infringement (tampering) | Exclusion from meeting |
| 5.01 (o) | Exhaust infringement (tampering) | Exclusion from meeting |
| 5.01 (o) | Restrictor plate infringement | Exclusion from meeting |
| 27.02 / 28.02 | Total exhaust length (midget/rookie) | Excluded from section of event |
| 25.24 | Airbox missing | Excluded from section of event |
| 25.09.2 | Exhaust missing | Excluded from section of event |
| 5.01 (r) 25.19 | Weight infringement | Excluded from section of event |
| Chapter 25 | Kart formula infringement | Excluded from section of event |

STEWARDS QUICK REFERENCE GUIDE

| OFFENCE | A.K.A. RULE | SUGG. PENALTY |
|--|-----------------------|----------------------|
| Abuse or intimidation | 5.01(a-e) | #1, #9 or #10 |
| Alcohol/Drugs – consumption | 1.33, 17.16 | #9 |
| Baulk line infringement | 17.04 & 5 | #5 |
| Baulking | 16.27 | #1 – #7 |
| Chequered Flag Infringement | 15.17 | #1 or #7 |
| Contact between karts | 16.23(a) | #1 – #10 |
| Dangerous or over aggressive driving | 16.23(b) | #1 – #10 |
| Driver's briefing – failure to attend | 16.02 | #1 |
| Ducking Head | 16.24 | #1, #2, #5, #6 or #7 |
| Engines – non conforming (as determined by STO, Chief Tech Insp, Chief Scrutineer) | 5.01(o) | #1, or #5 – #10 |
| Fuel infringement | 5.03(1), 5.01(q) | #8 – #10 |
| Instruction – failure to obey | 5.01(w) | #5 to #10 |
| Inspection – failure to present | 5.01(s), 12.02 | Refer to rule 12.02 |
| Kart – obstruction of circuit | 16.16 | #1, #5, #6, #7 |
| Kart Direction | 16.15 | #5 – #9 |
| Noise infringement | 24.2 | Refer to Rule 24.7 |
| Practice – failure to take part | 16.04 | Refer to Rule |
| Rejoining circuit | 16.18 | #2 – #8 |
| Restart during race | 16.10 | #1 or #9 |
| Scrutineering – failure to comply, to comply during the event. | Chapter's 12, 14 & 25 | #1 – #10 |
| Shaking hands whilst driving | 16.25 | #1 |
| Smoking | 17.14 | #1 |
| Speeding/Ingrid | 16.23(b) | #1 – #10 |
| Starts | 16.09 | #3 – #8 |
| Transponder | 16.05(d) | #1 or #7 |
| Tyres – incorrect use | 1.32 | #8 - #10 |
| Tyres – markings and / or recording | 1.32 | #7 |
| Weight infringement | 5.01(r), 5.03.2 | Refer to Rule #7 |
| Yellow flag – passing | 15.04, 15.10 | #2 or #5 – #8 |

6.05 Penalties from a Tribunal or Court:

1. A Tribunal, the AKAC or the AMSAC may impose any penalty except;
 - (a) The maximum fine which can be imposed by a Tribunal for a single offence is Two Thousand Dollars;
 - (b) The maximum fine which can be imposed by the Court for a single offence is Three Thousand Dollars;
 - (c) There is no maximum for other penalties.
2. The time limit for payment of fines / costs from a tribunal or court is 14 days from the date of the decision.
3. Some penalties are by these regulations imposed automatically. For example, suspension for failure to pay a fine/fee.
4. Suggested penalties from a Tribunal or Court.

| SUGGESTED PENALTIES LIST FOR TRIBUNALS | SUSPENSION |
|--|-------------------|
| Abuse / Intimidation of Official | 3 mth – 10 yr |
| Assault of Official | 1 yr – life |
| Assault / Intimidation of Competitor or Pit Crew or any other person | 3 mth – 5 yr |
| Non Conforming Engine | 3 mth – 3 yr |
| Non Conforming Fuel | 3 mth – 5 yr |
| Tyre Treatment | As per rule 23.03 |
| Alcohol / Drug Offences | 1 yr – 5 yr |

6.06 Action if Person Present at Time of Decision:

If the licence holder is present when the penalty is imposed:

- (a) the decision must be recorded on the competitors "electronic licence page".
- (b) If a fine has been imposed, the licence is automatically suspended until the fine has been paid in full.
- (c) Fines must be paid within fourteen (14) days of the date of decision.
- (d) Failure to comply with rule 6.06(c) will result in an automatic licence suspension. The period of automatic suspension is two days for every day between the date notified as the date by which the fine/fee had to be paid (14 days from the day of decision) and the date on which all directions in the notification have been complied with.
- (e) If a suspension has been imposed, the licence holder must be advised that the period of suspension commences immediately, (subject to provisions relating to appeals).

6.07 Address for Notification of Hearings and Penalty:

A notification of a hearing or penalty is effectively given if sent by ordinary mail to the address given on the application for the person's current kart licence, or the most recent subsequent address notified in writing to the Secretary of the State Karting Council.

6.08 If the licence holder is not present, the Tribunal Registrar must notify the licence holder by ordinary mail to the address referred to in the previous rule.

- (a) what penalty has been imposed.
- (b) that the penalty has been recorded on the competitors 'electronic licence page'.
- (c) if a fine has been imposed, then it must be paid within fourteen (14) days of the notification. **otherwise, rule 6.11 will apply.**
- (d) if a suspension has been imposed, that the suspension applies from the date of the imposition of the penalty.
- (e) there is, except in the case of the decision of the AMSAC, a right of appeal under these regulations.

6.09 Manner of Notification:

A licence holder may be notified of a penalty in person or as referred to in Rule 6.07.

6.10 Date of Notification if by Post:

If the licence holder is notified by post, the date of notification is deemed to be the second business day after the day of posting.

6.11 Suspension for Failure to Comply with Time Limits:

If the licence holder does not comply with the time limits for payment of a fine, the licence holder is automatically suspended.

The period of automatic suspension is two days for every day between the date notified as the date by which the fine/fee had to be paid (**14 days from the day of decision**) and the date on which all directions in the notification have been complied with.

6.12 Publication of Penalty:

The AKA shall have the right to publish or cause to be published the orders made by an Appeal Tribunal, including the AKAC, and to publish the names of all the parties to the appeal. Any person or body whose name is published pursuant to this rule shall have no cause of action against the AKA or against any person publishing such order.

For the avoidance of doubt, this rule authorises only the publication of the orders made and the names of the parties and does not authorise, in part or in whole, the publication of the judgment or publication of any transcript relating to the appeal proceeding.

CHAPTER 7

COMPLAINTS

- 7.01** A reference elsewhere in these regulations to a protest must be taken in this Chapter as a reference to a COMPLAINT.
- 7.02** A reference elsewhere in these regulations to a charge or report must be taken in this Chapter as a reference to a COMPLAINT.
- 7.03** A complaint may be made by;
- a) a body.
 - b) an official
 - c) a person directly affected.
- 7.04** A Complaint or appeal may be made about any act or omission, which is believed to be a breach of these regulations except:
- (a) a refusal of entry
 - (b) a decision of a judge or a judge of fact
 - (c) a direction to remove or cover advertising. (refer Rule 1.23)
 - (d) a starter's decision (refer Rule 16.09(vi))
 - (e) accuracy of scales
 - (f) the use of the red flag (refer Rule 16.11)
 - (g) Stewards decision re Chief Scrutineer's report (refer Rule 12.01(d))
 - (h) injured driver clearance (refer rule 16.22)
 - (i) baulk line (refer Rule 17.05)
 - (j) a decision made re Rule 16.05
 - (k) a decision concerning non-conforming tyre or tyres as the result of a test by a PID. Refer to rule 23.03
 - (l) a decision concerning non conforming noise level as a result of a test by a sound level meter. Refer R24.2
 - (m) a decision made regarding rule 23.01
 - (n) a decision from the **Clerk of Course** and Chief Steward pertaining to rule 1.32(a)
 - (o) a decision concerning non conforming fuel as the result of a test by a gas chromatograph. Refer to chapter 22.
- 7.05** A Complaint save a complaint in relation to the actions of an official, if lodged at a meeting must be made in writing to the Clerk of Course or Chief Steward on the correct form if available.
- 7.06** All other Complaints save a complaint in relation to the actions of a Steward, must be made in writing to the Tribunal Registrar.
- 7.07** A complaint in relation to an official must be made in writing to the National Tribunal Registrar. Complaints must relate to assault/intimidation of a competitor or pit crew or any person and not procedural or judgmental errors.
- 7.08** A written report of an official is a Complaint, if it states or implies that a regulation has been broken.
- 7.09** Where practical, a Steward who lays a complaint should not be involved in hearing that complaint, except when called as a witness.
- 7.10** A fee must be paid when a person makes a Complaint.
- 7.11** An official (of the day) does not have to pay a fee when making an official Complaint.

7.13 When the Tribunal Registrar receives a Complaint, a hearing of a Tribunal must be arranged save and except as provided by regulation 7.18. The date for the hearing of a disciplinary tribunal must be notified to all parties concerned within 90 days of receipt by the State Tribunal Registrar of the complaint.

7.14 The time limits for Complaints are as follows:

| NATURE OF COMPLAINT | | LATEST TIME FOR MAKING COMPLAINT |
|---------------------|---|---|
| (i) | Validity of entry, Right to take part | 2 Hours after end of time for scrutineering |
| (ii) | Handicap / Make up of heat Instructions to drivers or race | Half an hour before commencement of relevant heat |
| (iii) | Decision of Scrutineer | Immediately |
| (iv) | Anything happening during a race (ie. Between leaving the grid and returning to pit area) | Half an hour after returning to pit area |
| (v) | Decision of Technical Inspector | Half an hour after notification of decision |
| (vi) | Final results | Half an hour after announcement or display on the official notice board. Where results are notified by post or other means, 72 hours after results are transmitted. |
| (vii) | Any complaint concerning the actions of an official | A maximum of 2 (two) working days (excluding public holidays) after the incident complained of. |
| (viii) | Any other situation | Half an Hour after the alleged situation occurred. |
| (ix) | Complaints laid by Officials of the Meeting shall not be subject to the time limits set out in previous parts of this rule, but must be lodged "where practical" prior to the expiration of the relevant meetings permit. | |

7.15 The Stewards or Tribunal Registrar (whether national or state) may always permit a Complaint to be made out of time for a good reason.

7.16 A Complaint made at a race meeting must be dealt with by the Stewards unless there is a good reason why they cannot do so.

7.17 A Complaint not dealt with by the Stewards must be dealt with by a Disciplinary Tribunal save and except in relation to a complaint against an official which must be dealt with in the manner set forth in regulation 7.18

7.18 (a) A complaint against an official shall be made in writing and signed by the complainant and shall be accompanied by signed statements of witnesses (if any) to the incident complained of.
 (b) The written signed complaint and the signed witness statement or statements shall be forwarded to the National Tribunal Registrar by post within the time limited by regulation 7.14 (vii).
 (c) The National Tribunal Registrar, upon receipt of the material referred to in subparagraphs (a) and (b) hereof shall, in the first instance, in the exercise of his/her absolute discretion, decide if the nature of the complaint, prima facie, indicates that a breach of the regulations or rules

- has been committed by an official or is an issue of sufficient importance, or of sufficient weight or is a matter of public interest or is in the interest of karting generally, in which case, he/she shall refer the said material to a State Disciplinary Tribunal which shall be constituted for the purpose of considering and inquiring into the complaint and, if thought fit, imposing a penalty.
- (d) If the National Tribunal Registrar, in the exercise of his/her discretion, considers that the complaint is trivial or frivolous and vexatious then in that case, the National Tribunal Registrar may reject the complaint.
 - (e) No appeal shall lie against any decision made by the National Tribunal Registrar in exercising his/her discretion in any matter/s referred to in this regulation.
 - (f) The National Tribunal Registrar, if he/she considers that the complaint should be referred to a Disciplinary Tribunal, shall forward the material referred to in subparagraphs (a) and (b) hereof to the State Tribunal Registrar who in the opinion of the National Tribunal Registrar is the most appropriate to consider and determine the matter.

Stewards Hearings:

- 7.19** The procedure for a Stewards' Hearing is set out in this Chapter. The Stewards are not a Tribunal and Chapter 9 does not apply to them. Any necessary interviews by the Stewards of the Meeting must be conducted outside the racetrack area. (Refer to Definitions Chapter)
- 1) Where possible, all stewards hearings are to be recorded for proof of accuracy.
- 7.20** In the rest of this Chapter the person or body making the Complaint is called "the Complainant".
- 7.21** If the Complainant does not know what regulation is relevant, the Stewards must attempt to find the relevant regulation.
- 7.22** The Stewards must, when all parties are present, tell the other parties which regulation is believed to be relevant.
- 7.23** If the Stewards believe that a regulation is relevant which is different from that stated by the Complainant, all parties must be advised.
- 7.24** The Complaint must then be dealt with on that basis. It is the intention of these Rules that a person should not escape responsibility for a breach of these Rules because a Complaint is wrongly framed.
- 7.25** When a Complaint is made, the Stewards must decide which persons may be materially affected by the decision of the Complaint.
- 7.26** Those persons must then be invited to attend when the Complaint is dealt with.
- 7.27** A person need not be invited to attend if the only way in which that person may be affected is by being advanced in position (without being placed).
- 7.28** An invitation to attend the hearing of a Complaint made at a race meeting may be made by announcement on the public address system. However, the Stewards must ensure that a person against who a complaint has been made is aware of the hearing, by personal contact if necessary. Failure by the invitee to attend a hearing does not mean the complaint cannot be dealt with.
- 7.29** Any person under the age of 18 years who attend the hearing of a Complaint as either, the Complainant, the Defendant or a Witness, must be accompanied by a parent or adult guardian before being addressed by an AKA Official.
- 7.30** The young person may consult the adult, but the adult must not speak to the Stewards unless, in the opinion of the Stewards, the young person will suffer serious prejudice unless the adult is permitted to speak.

- 7.31** A person invited to attend the hearing of a Complaint may nominate another person to attend as the representative of that person.
- 7.32** The Stewards may treat the nominee, in the absence from the hearing of the nominator, in all respects as the nominator.
- 7.33** The nominator cannot complain of not being given an opportunity to speak or to exercise any other right, if the nominee is given that right while the nominator is absent from the hearing.
- 7.34** A Complaint made at a race meeting must be dealt with as soon as possible.
- 7.35** At least two Stewards must deal with a Complaint made at a race meeting.
- 7.36** The Complainant must outline the facts on which the Complaint is based and to produce evidence.
- 7.37** The other parties must then be asked what they have to say in support or in reply and to provide any other relevant evidence.
- 7.38** The Stewards must decide whether a regulation has been broken and, if so, who has broken it.
- 7.39** If it is decided that a regulation has been broken by a particular person, that person must be asked whether there is anything that person wishes to say which will be relevant in determining the appropriate penalty.
- 7.40** The Complainant must also be asked the same question.
- 7.41** The Stewards must decide whether the appropriate penalty is within the power of the Stewards as set out in these Regulations.
- 7.42** Types of Penalties: (during a race meeting)
The stewards of the meeting may impose a penalty consisting of ONE or More of the following:
1. A fine (up to \$1,000.00)
 2. Revise finishing order
 3. Revise grid position
 4. Time penalty
 5. Place Penalty
 6. Points Penalty
 7. Exclusion from that section of the event
 8. Exclusion from the event
 9. Exclusion from the meeting
 10. Suspension (up to 6 months)
- 7.43** **Exclusion and referral for penalty. Refer rule 6.03 (c)**
The Stewards must also advise the parties what penalty, if any, will be recommended to the Tribunal, but advise that the Disciplinary Tribunal may vary the penalty.
- 7.44** In all other cases the Stewards must decide what is the appropriate penalty. Any penalty shall be given in writing on the AKA official form.
- 7.45** If the Stewards do not make a decision which is favourable to the Complainant or if the complaint is withdrawn, the fee for the complaint shall normally be forfeited.
- 7.46** Once a decision on a Complaint is made, all parties must be advised of their right of appeal (Refer Rule 8.09 and 8.10) for vital conditions if an Appeal involves engines/fuel/accessory or part).

CHAPTER 8

APPEALS

8.01 There are **six** kinds of appeals:

- (1) an appeal from a decision of the Stewards from a Steward's Hearing conducted as part of any race meeting other than a National Event (State Open Championship, National Championship or CIK event), to an Appeal Tribunal.
- (2) an appeal from a decision of a Disciplinary Tribunal to the Australian Karting Appeal Court (AKAC).
- (3) an appeal from a decision of the Stewards from a Steward's Hearing conducted as part of a National Event (State Open Championship, National Championship or CIK event) to the Australian Karting Appeal Court (AKAC).
- (4) an appeal from a decision of an Appeal Tribunal to the Australian Karting Appeal Court (AKAC).
- (5) an appeal from a decision of the Australian Karting Appeal Court (AKAC) to the Australian Motor Sport Appeal Court (AMSAC). All appeals to the AMSAC are subject to leave being granted by the AMSAC.
- (6) an appeal to the AMSAC on the grounds that a decision of the NKC or the Secretariat was not within the power of that body or was otherwise unconstitutional.

8.02 Eligibility to Appeal:

"A party to proceedings conducted as a Steward's Hearing, a Disciplinary Tribunal or an Appeal Tribunal may appeal the decision of that Steward's Hearing, that Disciplinary Tribunal or that Appeal Tribunal on the grounds of severity of penalty, error of law, error of fact. For the avoidance of doubt, a party is a person or entity who has appeared in **the proceeding as a Defendant, a Complainant, a Prosecutor, or a person or entity otherwise joined in the proceeding or a competitor directly involved in the incident leading to the hearing**"

There can be no appeal against a 'not guilty' verdict from a Stewards Hearing, Disciplinary Tribunal or Appeals Tribunal.

- 8.03** A State Karting Council or the AKA Secretariat or the National Karting Council may appeal to an Appeal Tribunal, the AKAC or the AMSAC if it is satisfied that an appeal should be brought in the best interests of karting. These bodies shall not be subject to the time limits set out in rule 8.04 and shall not be required to pay an appeal fee.

8.04 Procedures, Time Limits and Fees for Lodgement of an Appeal:

- (a) To lodge an appeal against a "Steward's Finding" from a Steward's Hearing conducted as part of any race meeting other than a National Event (State Open Championship, National Championship or CIK event), to an Appeal Tribunal, the Appellant must complete an AKA "Intention to Appeal" form and hand it to a Steward of the meeting, with the appropriate fee of \$550.00, within one (1) hour of the handing down of the Steward's Finding being appealed. The Appellant must then complete an AKA "Notice of Appeal" form, setting out the details of the appeal, and either hand deliver it to the Steward's at the meeting, or post it (by Registered Mail) to the State Tribunal Registrar before 12 midnight on the third (3rd) day after the day of decision.

(b) To lodge an appeal against a “Steward’s Finding” from a Steward’s Hearing conducted as part of a National Event (State Open Championship, National Championship or CIK event), the first avenue of appeal is to the Australian Karting Appeal Court (AKAC). The Appellant must complete an AKA “Intention to Appeal” form and hand it to a Steward of the meeting, with the appropriate fee, (\$1,100.00 for an appeal in writing or \$2,200.00 for an appeal in person), within one (1) hour of the handing down of the Steward’s Finding being appealed. The Appellant must then complete an AKA “Notice of Appeal” form, setting out the details of the appeal, and either hand deliver it to the Steward’s at the meeting, or post it (by Registered Mail) before 12 midnight on the third (3rd) day after the day of decision to the ;

AKA National Tribunal Registrar
P.O. Box 4222, Penrith Westfields
Penrith, N.S.W. 2751
Email: court@austkarting.com.au

(c) To lodge an appeal against a decision from a “Disciplinary Tribunal” or an “Appeal Tribunal” to the Australian Karting Appeal Court (AKAC), the appellant must complete an AKA “Notice of Appeal” form setting out the details of the appeal, and post it (by Registered Mail) to the National Tribunal Registrar before 12 midnight on the seventh (7th) day after the handing down of the decision of the appeal, with the appropriate fee (\$1,100.00 for an appeal in writing or \$2,200.00 for an appeal in person).

(d) To lodge an appeal against a decision from the Australian Karting Appeal Court (AKAC), to the Australian Motor Sport Appeal Court (AMSAC) the appellant must complete an AKA “Notice of Appeal” form setting out the details of the appeal, and post it (by Registered Mail) to the National Tribunal Registrar before 12 midnight on the seventh (7th) day after the handing down of the decision of the appeal, with the appropriate fee (\$6,600.00). All appeals to the AMSAC are subject to leave being granted by the AMSAC.

8.05 “A Tribunal Registrar may only accept an out of time “Intention to Appeal or Notice of Appeal form” from a decision of a steward’s hearing, a decision of an Appeal Tribunal, a decision of a Disciplinary Tribunal or a decision of the AKAC, if the appellant provides in writing a ‘good reason’ why he/she was prevented from delivering the relevant forms within time, providing it is hand delivered or posted by registered mail and received by the appropriate Tribunal Registrar within 72 hours out of time, with the appropriate fee.

“In the above clause, the expression ‘good reason’ refers only to some difficulty in the process of delivery of the forms and the Tribunal Registrar will not take into account any merits of the appellant’s proposed case.”

8.06 Any Appeal out of the time limit specified in rule 8.05 (72 hours) shall not be accepted for lodgement.

8.07 A Notice of Appeal form shall indicate whether the Appeal is an appeal against a conviction, a penalty, or against both and shall fully set out the grounds of appeal.

1) A Tribunal Registrar may only accept an out of time “Intention to Appeal or Notice of Appeal form” from a decision of a steward’s hearing, a decision of an Appeal Tribunal, a decision of a Disciplinary Tribunal or a decision of the AKAC, if the appellant provides in writing a ‘good Reason’ why he/she was prevented from delivering the relevant forms within time, providing it is hand delivered or posted by registered mail and received by the appropriate Tribunal Registrar within 72 hours out of time, with the appropriate fee. “In this clause, the expression ‘good reason’ refers only to some difficulty in the process of delivery and the Tribunal Registrar will not take into account any merits of the appellant’s proposed case.

8.08 The body hearing an appeal has the discretion to permit an appellant to rely on a ground not set out in the Notice of Appeal.

8.09 Appeals concerning and Engine or Part (as per rule 5.01(o))

- (1) If a person appeals against a decision with respect to an offence committed against Rule 5.01 (o), then the engine, the part or the accessory found to breach Rule 5.01(o) shall:
 - (a) be handed to the Clerk of the Course or the Clerk's Deputy; and
 - (b) be sealed for transmission to the Tribunal, the AKAC or the AMSAC; and
 - (c) remain sealed until the engine, the part or the accessory is inspected in the presence of the Appellant or the Appellant's representative and a person or persons approved by the appropriate Tribunal Registrar.
- (2) If the engine, the part or the accessory is:
 - (a) removed from the inspection area at any time by anyone except an Official of the meeting;
 - (b) not personally handed to the Clerk of the Course or the Clerk's Deputy; or
 - (c) altered at any time it is in the inspection area by either the Appellant or a member of the Appellant's crew or by any other person, then the evidence used to found the offence shall be accepted as correct on the hearing of the Appeal.

8.10 Appeals concerning Fuel or a Lubricant (as per rule 5.01(q))

- (1) When a person is found to have used a fuel, lubricant or other substance not permitted by the regulations, and that person then wishes to appeal against the finding, then an appropriate Official must, in the presence of the person intending to appeal, or that person's representative:
 - (a) take a sample or samples of the fuel, lubricant or other substance and place those samples in an airtight container(s);
 - (b) seal the airtight container(s) containing the sample(s) and forward the container(s) to the appropriate Tribunal Registrar or to an address directed by the Registrar.
- (2) If the sample(s) referred to in 8.14(a) is to be further tested, then the seals on the airtight container(s) must be verified as intact by an approved person immediately prior to the commencement of testing of the sample(s).
- (3) An approved person is a person who is a member of, or eligible for membership of the Royal Australian Chemical Institute or a similar body approved by the AKA.
- (4) It is an offence for a person whose fuel, lubricant or other substance is to be tested or for the crew of that person or for any other person:
 - (a) to alter any part of the test material in any way;
 - (b) to remove any part of the material to be tested from the inspection area without the permission of the tester;
 - (c) to remove, alter or damage any sealed sample at any time.
- (5) If a person commits an offence under Regulation 8.10.4, then the evidence of the fuel tester as to the legality of the fuel, lubricant or other substance shall be accepted by the body hearing the Appeal, and no evidence of whatsoever nature shall be accepted by or on behalf of the Appellant concerning the legality of the fuel, lubricant or other substance.

8.11 Exclusion or Suspension:

- (1) When a Notice of Intention to Appeal or Notice of Appeal form is lodged, a penalty of exclusion or suspension shall only take effect prior to the hearing of the Appeal when;
 - (a) the decision cannot be the subject of a complaint and therefore cannot be appealed against, or
 - (b) the decision appealed against was made under Rule 4.09(h), (i) or (j), or
 - (c) the decision appealed against relates to an offence referred to in Rule 12.02 in which case a penalty of exclusion or suspension takes effect immediately.
- (2) When an Appellant is advised in writing that the Appeal will be heard within one month from the date of the decision appealed against, the penalty of exclusion or suspension shall take effect on the later of:
 - (a) the end of the event to which the Appeal relates, or
 - (b) the date on which the Appellant receives written notification of the result of the Appeal.
- (3) Any driver who's appeal against a licence suspension is subsequently dismissed, may have their original licence suspension increased

8.12 Any person participating in any AKA sanctioned competition whilst under Appeal shall not receive any award, trophy or points in the event that gave rise to the Appeal unless the Appeal is successful.

8.13 Rights of Withdrawal of an Appeal:

Appeals may be withdraw at any time prior to either (1) a directions hearing or (2) the hearing of the appeal (which ever occurs first), provided the appellant does not practice, race or act as an Official at any AKA licenced track whilst under appeal, when, all rights to be able to withdraw the appeal will be forfeited.

8.14 Time Limits for Notice of Hearing of an Appeal:

- (a) The appropriate Tribunal Registrar shall ensure that a Notice of Hearing of the Appeal is forwarded to the Appellant and any other parties to the Appeal not later than:
 - (i) 10 days before the date on which the Appeal is to be heard.
 - (ii) 17 days before the date on which the Appeal is to be heard in matters where the Appellant is normally domicile in a State other than the State in which the Appeal is to be heard.
- (b) A Notice of Hearing of Appeal may be delivered personally. A Statutory Declaration is required by the person who delivers the notice. A posted or faxed Notice of Hearing shall be deemed as proof, or a proof of delivery slip for a registered letter.
- (c) The date for hearing of the Appeal shall be notified to all parties concerned within 30 days of receipt by the appropriate Tribunal Registrar of the Notice of the Appeal or within 30 days of any directions hearing whichever is the latter.
- (d) Failure by the appropriate Tribunal Registrar to notify all parties to the Appeal within the required time limit shall result in the Appeal being decided in favour of the Appellant and the appeal fee shall be returned to the Appellant.
- (e) Any date set for hearing of the Appeal shall be within 30 days of the date of receipt by the Appropriate Tribunal Registrar of the Notice of Appeal or within 30 days of the date of any directions hearing, whichever is the later, except that the date of the hearing of the Appeal may be altered by consent of the parties to the Appeal.

8.15 Directions hearings:

If the appropriate Tribunal Registrar forms the view that a matter under Appeal involves complex scientific or technical evidence, then that Registrar may request the Chairperson of the Tribunal to conduct a telephone directions hearing. The Tribunal Chairperson has the power at a directions hearing to direct the parties to exchange technical or scientific information by a date that shall not be less than one week prior to the hearing, and may give directions concerning tests or other matters, including directions for adjournments with a view to simplifying the matters in dispute. Any material that is directed to be provided to any party to an Appeal and is subsequently not provided as so directed shall not be admitted into evidence at the hearing unless all parties to the Appeal agree to its admission.

8.16 If an Appellant wishes to raise legal argument concerning :

- a) the right of the Tribunal, the AKAC or the AMSAC to hear the Appeal or
- (b) the validity of the regulations on which the decision appealed from is based, then a written statement of the legal argument to be raised must be received by the appropriate Tribunal Registrar at least 7 days prior to the date set for the hearing. Failure to comply with this rule will result in such argument being disallowed.

8.17 A body hearing an Appeal may impose or vary any penalty provided such imposition or variation is within the range of penalties it is empowered to impose pursuant to the provisions of this manual.

8.18 A body hearing an Appeal may not order a race to be re-run.

8.19 A body hearing an Appeal may alter any decision made by an Official or Officials or by a State Karting Council.

8.20 A body hearing an Appeal shall not alter a decision of the National Karting Council unless the body decides that the decision:

- (a) was not within the power of the National Karting Council to make, or
- (b) was not permitted by the registered Rules of the AKA ,or
- (c) was not permitted by these regulations.

8.21 An Appeal fee shall be returned to the person appealing if:

- (a) the Appeal is successful, or
- (b) the body hearing the appeal considers that there are exceptional circumstances which warrant the return of the fee.

8.22 "The AKA shall have the right to publish or cause to be published the orders made by an Appeal Tribunal, including the AKAC, and to publish the names of all the parties to the appeal. Any person or body whose name is published pursuant to this rule shall have no cause of action against the AKA or against any person publishing such order. For the avoidance of doubt, this rule authorises only the publication of the orders made and the names of the parties and does not authorise, in part or in whole, the publication of the judgment or publication of any transcript relating to the appeal proceeding."

- 8.23** If an Appeal is on the grounds that the procedure adopted at a Steward's hearing or at a Tribunal was not in accordance with these regulations, then the body hearing the Appeal must determine whether the failure to follow the regulations was so serious that the decision appealed against should not stand. If the body makes a determination that the decision cannot stand, then that body shall re-hear the matter or refer it for re-hearing. Failure to follow procedures will not result in dismissal of a complaint by an appeal body.
- 8.24** If an Appeal Tribunal or the AKAC forms the view that an Official has acted improperly, it may:
- (a) call upon that Official to state, after an adjournment if necessary, why he or she should not be prohibited from acting as an Official for a period of time and
 - (b) after considering all relevant material presented to it, prohibit the Official from acting as an Official or a particular Official for a stated period.
- 8.25** Appeals directed to the AMSAC are subject to the AMSAC's own time limits and rules and not those referred to in regulation 8.14 (a) (c) and (e).

AKA APPEALS COURT

8.26 Preamble

The Australian Karting Appeal Court (AKAC) is karting's own Court of Appeal which shall be chaired by an accredited AKAAP. The aim of AKAC is to provide a Court of Appeal whereby appeals are available by way of right and not by way of leave as is the case with the AMSAC. The intention is to be able to conduct appeal hearings where Appeals involve less expense on the part of all parties and where Appeals can be heard more quickly than through the AMSAC. The right to seek leave to appeal to the AMSAC shall remain. It is the intention of the AKAC to keep its processes as flexible as possible by, amongst other things, encouraging Appeals to be by way of written submissions rather than in person, and by conducting Appeals via telephone hook-up and if feasible via vCOURTideo-link.

8.27 Constitution

- a) The AKAC is a duly constituted body that is independent of the AKA and specifically charged with hearing Appeals arising from decisions of an Appeal Tribunal or a Stewards Hearing from a National Event (State Open Championship, National Championship or CIK Event).
- b) Any body, official or person affected by any decision of an Appeals Tribunal or a Stewards Hearing from a National Event (State Open Championship, National Championship or CIK Event) may appeal to the AKAC.
- c) A State Karting Council or the AKA Secretariat or the National Karting Council (NKC), may appeal to the AKAC if it is satisfied that the Appeal should be brought in the best interests of karting.

8.28 Composition

- a) The AKAC shall comprise three (3) members, at least one of whom shall be an AKAAP
- b) An AKAAP shall chair the court. (Australian Karting Association Appeals Person)
- c) The chairperson shall have the powers to act as the Court Registrar but may appoint an independent person to act as the Court Registrar.

8.29 Time

- a) A Notice of Appeal shall be lodged with the AKAC Registrar at the AKA National Office within 7 days of the handing down of the decision that is being appealed, **unless it is a Notice of Appeal from a Steward's Hearing from a National Event (State Open Championship, National Championship or CIK Event) when rule 8.04(b) will apply in all respects.** Notices of Appeal should preferably be lodged by email addressed to court@austkarting.com.au
- b) The Notice of Appeal shall be in writing and in a form approved by the AKAC and accompanied by the appropriate fee. Where a Notice of Appeal is lodged by email, the Appeal shall be deemed to have been lodged only when the Appeal fee is received by the AKAC Registrar.
- c) The AKAC may allow an Appeal out of time upon application being made to it in writing setting out the reasons for the out of time application, **as per rule 8.05.** Such reasons shall be satisfactory to the AKAC before it shall allow the Appeal. No application shall be accepted by the AKAC when such application is received more than 72 hours out of time. The proposed Notice of Appeal shall be lodged with the application together with a late application fee, which fees are as follows:
 - (i) where the Appeal for which leave is sought is to be by written submissions only, \$100;
 - (ii) where the appeal for which leave is sought is to be in person, \$200;
- d) An Appeal by a State Karting Council or the AKA Secretariat or the National Karting Council (NKC) shall be lodged within **60** days of the handing down of the decision being appealed and rule (c) above shall not apply.

8.30 Fees

- a) The fee for an Appeal to the AKAC is \$2,200 (including GST) where an Appeal in person is required, or
- b) \$1,100 (including GST) where an Appeal is required by way of written submissions only.
- c) A State Karting Council or the AKA Secretariat or the NKC is not required to pay an appeal fee or late fee.

8.31 Notices

- a) A Notice of Appeal must state whether the Appeal is an appeal against a conviction, a penalty, or both and shall fully set out the grounds of Appeal.
- b) The AKAC may allow an Appellant to rely on a ground of Appeal not set out in the Notice of Appeal provided that such ground is not prejudicial to any other party to the Appeal.
- c) The AKAC Registrar shall ensure that a Notice of Hearing of the Appeal is forwarded to the Appellant and any other parties to the Appeal not later than:
 - (iii) 10 days before the date on which the Appeal is to be heard.
 - (iv) 17 days before the date on which the Appeal is to be heard in matters where the Appellant is normally domicile in a State other than the State in which the Appeal is to be heard.
- d) A Notice of Hearing of Appeal may be delivered personally, by post, by email or by facsimile. A Statutory Declaration duly declared by the person who delivered personally, posted, emailed or faxed the Notice shall be deemed as proof of personal delivery, emailing, posting or faxing.
- e) The date for hearing of the Appeal shall be notified to all parties concerned within 30 days of receipt by the appropriate AKAC Registrar of the Notice of the Appeal or within 30 days of any directions hearing, whichever is the latter.

- f) Time frames in this rule 8.31 may be varied by the National Tribunal Registrar or by the AKAC in circumstances where variation is warranted and such variation is convenient to the court.

8.32 Directions

- a) The National Tribunal Registrar or the Chairperson may at any stage prior to the date fixed for the hearing, conduct a directions hearing to ascertain each parties understanding of the issues at large, the parties preparedness for hearing, what material should be exchanged between the parties and otherwise as provided for in rule 8.15.
- b) Subject to this rule 8.32, the National Tribunal Registrar or the Chairperson shall give the parties a timetable for the parties to provide a written outline of the submissions to be made to the AKAC. A copy of such written outline shall be provided to the AKAC and to each party to the Appeal.

8.33 Hearings

- a) Hearings shall preferably take place by telephone conference but otherwise, at a location determined by the AKAC Registrar.
- b) An Appellant's attendance at hearings and associated costs shall be at the Appellant's sole cost.
- c) An appellant may be represented by an advocate but only with leave of the court. Advocates shall not be persons who are legally qualified. An application for leave to be represented by an advocate shall be lodged with the AKAC not less than 14 days prior to the date fixed for hearing. Such application shall be in writing and shall at a minimum state the name of the advocate and the reason that leave is sought to be represented by an advocate.

8.34 Penalties

- a) The AKAC when hearing an Appeal may impose or vary any penalty provided such imposition or variation is within the range of penalties it is empowered to impose pursuant to the Provisions of this manual.

Any driver who's appeal against a licence suspension is subsequently dismissed, may have their original licence suspension increased.

- b) The AKAC may alter any decision made by an official or officials or by a State Karting Council.
- c) AKAC may not alter a decision of the National Karting Council unless it decides that the decision:
- (i) was not within the power of the National Karting Council to make or
 - (ii) was not permitted by the registered Rules of the AKA or
 - (iii) was not permitted by these regulations.
- d) An Appeal fee will only be returned to the Appellant if:
- (i) the Appeal is successful or
 - (ii) The AKAC considers that there are exceptional circumstances, which warrant the return of the fee.
- e) Notwithstanding rule 8.34, an out of time application fee is not refundable in any circumstances.

8.35 "The AKA shall have the right to publish or cause to be published the orders made by the AKAC and to publish the names of all the parties to the appeal. Any person or body whose name is published pursuant to this rule shall have no cause of action against the AKA or against any person publishing such orders.

For the avoidance of doubt, this rule authorises only the publication of the orders made and the names of the parties and does not authorise, in part or in whole, the publication of the judgment or publication of any transcript relating to the appeal proceedings."

8.36 Further Appeal

- a) The Appellant has the right to appeal against the decision of the AKAC to AMSAC. This is subject to AMSAC time limits and rules. As laid down in the 2011 CAMS Manual of Motor Sport. Section 5: Judicial, Appendix G.

9.01 The Machinery of Justice:

In the course of normal competition, whether it be as affecting an organiser, an official or a participant, occasions arise from time to time which require adjudication of disputes, or the just settlement of conflicting interests. Moreover, the discipline necessary in all organised activity, and vital in motor sport are maintained by a system of law which involves the enacting of Rules and Regulations, the appointment of officials to administer them and the provision of machinery to impose penalties for breaches of them.

Provision has been made by the AKA for the discharge of all these functions. In accordance with the Code, general laws applicable in Australia have been enacted and published, and form the Rules embodied in this Manual. Further restrictions, in more particular detail, are published from time to time in Supplementary Regulations and Agenda of individual events.

To police these rules and regulations, the AKA appoints from time to time individual officials such as Stewards and Clerks of the Course and requires organisers to appoint others, such as Scrutineers, Secretaries, Timekeepers and so on each with their duties and responsibilities. The Stewards of the Meeting have by right (and others may have by special delegation) certain powers to impose penalties and it follows that there should exist avenues of appeal which may be followed by any persons penalised by them. Similarly, persons against whom any action has been taken, though not of punitive nature, should have the opportunity to lodge a complaint, except in certain special cases.

Lastly, those who commit offences against the Rules in circumstances unrelated to a meeting, or of a kind which appears to merit penalties beyond the power of Stewards to inflict, are liable to be charged with those offences. In such cases, they are entitled as of right to be confronted by their accusers, to hear the evidence against them, to test that evidence and call their own, and to be assured of impartial justice.

All these requirements and the need to provide avenues of appeal referred to above, have resulted in the authorisation by the AKA, or affiliated State Karting Councils, to appoint what are known as Tribunals.

9.02 The Duality of Tribunals:

Tribunals are of two kinds, viz.

- (a) **DISCIPLINARY TRIBUNALS:** which are essentially minor courts, are set up to try cases brought before them by the AKA, by way of charges against persons or groups subject to AKA Disciplinary Tribunals and have two primary duties:
 - (i) to determine whether or not a charge heard is proved, and
 - (ii) if so, to impose the appropriate penalty.
 - (iii) To these may be added the right to make any recommendation to the AKA, that may seem fitting and relevant.
 - (iv) A Disciplinary Tribunal may also have the responsibility of determining a penalty, if the Stewards after conviction, determine that a penalty is warranted which they are not authorised to impose. In that case, the written statement of the Stewards that the charge has been found proved shall be conclusive evidence of that fact and so much of this chapter as applies to the proving of the case shall not apply to that hearing.

(b) APPELLATE TRIBUNALS:

which are appointed to hear pleas arising from decisions by:

- (i) Officials of a Meeting, or
- (ii) Disciplinary Tribunals. Appellate Tribunals are obliged to confine their decisions to matters actually appealed, though they are free also to make recommendations to the AKA, arising out of their deliberations.

9.03 Stewards Hearing:

Stewards conducting a hearing at a race meeting are not a Tribunal under this Chapter.

9.04 Constitution of Tribunals:

Certain basic qualifications are required of any person acting in a judicial capacity. He/She must not for instance, be involved personally or have any interest in the matter at issue, he/she must have had no connection, other than as a spectator, with any meeting where the matters arose; he/she must have had no prior contact with, or made any decision affecting the matter at issue; he/she must be impartial and must take into account only the evidence brought before him/her and he/she must act only in accordance with the body of law under which he/she is appointed.

In Karting it is not always easy to find such persons. It is not desirable (in general terms) for those who enact laws also to interpret them, and hence the voting national councillors of the NKC are virtually stopped as judicial officials. It is not desirable for administrative officials to act in a judicial capacity, especially in disciplinary tribunals, as frequently they are involved in prosecuting charges and it is undesirable to appoint active organisers and competitors to such positions primarily because of their potential or actual interests in events or persons.

9.05 Conduct of Tribunals:

Location and Arrangement: A suitable room, with adequate space for the tribunals, the parties and witnesses, and preferably in a neutral venue should be selected. The bench should be at one end, flanked at right angles by tables for each party with a chair at least for witnesses in front of the bench. Provisions may be made for the press, if the Tribunal permits press reporting, and arrangements must be made to record the hearing in full, preferably on tape. A party or a witness may, subject to approval of the Tribunal, take part in the proceedings by telephone conference.

1. Procedure at Disciplinary Tribunals:

- (a) The Chairman should announce the opening of the Tribunal, stating its authority, its composition, and the purpose of its sitting. Leave may be granted for advocates to represent the parties, and if so appearances are then taken. Representation by the Legal Profession or Police Force is not permitted.
- (b) The accused is to be asked whether he/she objects to any member sitting if so, on what grounds. If no objection is received, the case proceeds. If an objection is received, it must be examined and may involve one or more member being declared ineligible to sit. (If more than one member steps down as ineligible the hearing must be adjourned, two being the minimum number acceptable on the bench). If the objections are not considered valid, they may be overruled by the Tribunal, and the case will then proceed. (In such case the objection must be noted and in due course included in the transcript of the proceedings).

- (c) The complaint or complaints shall then be read to the accused, either by a clerk of the tribunal (if there is one) or by the Chairman and the accused will plead to each complaint. If a plea of "guilty" is received, the proceedings in such case may be shortened but the onus still lies on the prosecution to produce evidence in support of such complaint. If a plea of "not guilty" is received, the case proceeds as follows:
- (d) The prosecution proceeds first, and is normally required to adduce evidence of the existence of a rule or regulation allegedly breached, and evidence of the breach.
- (e) If a Tribunal believes that a regulation is relevant which is different from that stated by the Complainant, all parties must be advised. The complaint must then be dealt with on that basis, after adjournment, if that is necessary. It is the intention of these regulations that a person should not escape responsibility for a breach of these regulations because a complaint is wrongly framed.
- (f) The defence may then lead evidence in rebuttal of the prosecution's case.
- (g) The defence will then address the Tribunal, summarising the case for the accused.
- (h) The prosecution will then address the Tribunal, summarising the case for the prosecution.
- (i) The Tribunal will then determine the guilt or otherwise of the accused, adjourning the Tribunal if necessary to do so. No other persons shall be present or partake in any discussion with the Tribunal at this stage, unless the Tribunal has both parties before it together.
- (j) The Tribunal may hear arguments if any on the question of costs and may make or not make an award of costs as is proper and fitting in all of the circumstances provided always that no costs shall be awarded against the AKA Incorporated, a Member Karting Association or any member club of a Member Karting Association unless any of these bodies are an unsuccessful appellant.
- (k) If the Tribunal finds the complaints or any of them proved, it shall announce a finding of "guilty" and then hear argument on the question of penalty.
- (l) The Tribunal shall determine and announce whether a penalty is imposed, and if so, its nature (and if relevant, the duration of a term of suspension).
- (m) The Tribunal, in giving judgement for or against the accused, shall do so by writing down its judgement and reading it aloud to the parties appearing. Such judgement shall include the Tribunal's reasons for its findings, and shall include a statutory reminder to the parties of their rights of appeal. Such judgement may, moreover, include any recommendation which the Tribunal deems fitting.
- (n) The Chairman will then declare the proceedings closed.

2. Procedure at Appeal Tribunals:

- (a) The Chairman will announce the Tribunal's authority, its composition and its purpose. Leave may be granted for advocates to represent the parties, and if so, appearances will then be taken, representation by the Legal Profession or Police Force is not permitted.
- (b) To shorten the proceedings, the parties may at this stage stipulate certain facts of the admissibility of certain documents (eg. if a transcript summary, or both, has been made available to the Tribunal and to both parties, of either proceedings giving rise to the appeal, such may be stipulated as accurate on appeal).
- (c) The appellant goes first, addressing the Tribunal and/or calling evidence.
- (d) The respondent follows similarly also addressing the Tribunal and/or calling evidence.
- (e) The respondent then makes his/her final address, if he/she desires to do so.
- (f) The appellant then makes his/her final address, if he/she desires to do so.

- (g) The Tribunal then determines whether, and if so, to what extent, the appeal shall succeed, adjourning the hearing if necessary in order to do so.
- (h) No other persons shall be present or partake in any discussion with the Tribunal at this stage, unless the Tribunal has both parties before it together.
- (i) The Tribunal shall then deliver its judgement by writing it down and reading it aloud to the parties concerned. Such judgement shall include the reasons for the findings, a statutory reminder to the parties of their rights of appeal, if any, and also a direction as to the disposition of the Appeal Fee, either by way of its return to the Appellant (if the appeal has succeeded) or its estreatment by the AKA (if the appeal has failed).
- (j) The Tribunal may hear arguments if any on the question of costs and may make or not make an award of costs as is proper and fitting in all of the circumstances provided always that no costs shall be awarded against the AKA Incorporated, a Member Karting Association or any member club of a Member Karting Association unless any of these bodies are an unsuccessful appellant.
- (k) The Chairman will then declare the proceedings closed.

9.06 Witnesses and Examination:

Procedure: Witnesses are presumed to be speaking the truth. They may be examined by the party calling them, and shall give evidence directly and/or by answers to questions. They may not be "led" on examination by the advocate calling them, that is to say, they may not be asked questions generally which put words into their mouths, though this is relaxed somewhat for formal identification, etc.

On cross-examination this does not apply.

Questioning may take the form of "leading" or suggestions, and opposing counsel is entitled to test the credibility of the other side's witnesses. Re-examination, ie. questioning by the witnesses' own side, is usually confined to clarification of matters raised in cross-examination.

9.07 The Nature of Evidence:

Direct evidence is usually the oral evidence of a witness (though it may include documentary evidence as below), and is given by some person who himself saw or heard or otherwise perceived the fact or facts to which he/she testifies.

"Hearsay" evidence (ie. evidence that the witness was told something) is not valid evidence of the thing itself, and is usually inadmissible as such. A witness may have been told this; it is no evidence that the kart did go over the fence.

"Opinion" is not in itself generally admissible. An exception is when a person is accepted by the Tribunal as an "expert" in respect of the particular matter at issue. For example, any engineer or a doctor or even a noted driver may qualify or be stipulated as an expert in his/her particular field, and hence give expert opinion as evidence. He/She will, however, be subject to cross-examination in such areas of evidence and his/her evidence will be evaluated, not by other experts in his/her field necessarily but by the Tribunal.

Opinions expressed by witnesses other than experts are valueless as evidence of the matter at issue, though they may be illuminating as to the credibility of the witness. They are inadmissible. Documents may be tabled in evidence; in such case, they must be proved as to their source, validity, relevance, etc. and to do so it may be necessary to call direct evidence (eg. an official letter from a company, a parts manual, etc.) Things may be submitted as evidence, to speak for themselves, as for instance a cylinder head in question. Other evidence is usually required to prove the authenticity or relevance of such "real" evidence.

Circumstantial evidence, the fact of the existence of a number of situations or occurrences or circumstances may be put in. It may be cogent (a man seen running from the otherwise deserted scene of an offence at the time it was committed) or it may be valueless but it is admissible.

It is not permitted to introduce, prior to conviction, any evidence relating to other convictions. However, should a person be found guilty of a charge, the fact of his/her earlier breaches of the Rules may relevantly be pressed in pleas as to penalty. They must be established, mere suspicion only of these is inadmissible unless, of course, admissions have been made by the accused person. Similarly it is forbidden to introduce material in addresses that could have been and should have been produced in evidence. Failure to give evidence is not in itself an admission of guilt, but it may give rise to certain conclusions by reasonable men; the innocent usually in human experience assert their innocence, and failure to do so while subject to examination is rightly capable of being interpreted as an admission of guilt.

Judicial Notice. Certain facts need not be proved by evidence in respect of AKA Tribunals. The general authority of the Tribunal to sit is assumed, if stated (subject to objections as to its individual members) the booklet entitled "Australian Karting Association Manual" is taken to be an official AKA publication, and the Rules and Regulations included therein together with any amendments notified by the National Secretary to all State Secretaries to be the National Competition Rules and Regulations applying to the hearing. Persons acting as officials of a meeting are assumed to have been properly appointed, though if called as witnesses they usually assert the same to be so, the AKA are by statute entitled to intervene in any Tribunals, whether or not an opposing party; the meaning of the English language is presumed to be as understood by ordinary men, and so on. There would be no end to litigation if everything had to be proved.

Tribunals also take judicial notice of decisions handed down by the AMSAC.

9.08 Degree of Proof:

In civil cases (such as AKA affairs usually are), the degree of proof is usually required only to be by the preponderance of evidence – they are settled on the balance of probability, ie. what seems most likely from the evidence. Although some social or sporting stigma may accrue to persons found guilty of a charge under the Rules of a sporting body, it is not usually sufficient to justify the necessity of proof "beyond reasonable doubt", though such a case could arise.

9.09 General Conduct:

Though AKA Tribunals do not have either the status or the authority of Courts of Law, though witnesses can neither be compelled to attend or give evidence, and though many of the parties and the Tribunal members are known to each other more or less well, there can be no justification for informality prevailing at hearings of Tribunals (other than in isolated instances of natural humour).

Formality, the maintenance of form, is a means of ensuring that (a), all the things that ought to be done are in fact done in an orderly manner and (b) that nothing that should not be done is done. An added effect is that of natural gravity, the ceremony associated with formality always lending to proceedings the appropriate air of seriousness.

Informal proceedings may achieve a just end, but they seldom appear to do so. The Tribunal in such loses stature and authority and the law itself becomes, or may become, an object of contempt. The use of first names, the relaxing of basic rules of evidence, lapses from decorum, the permissibility granted to interjectors, the acceptance of casual or intemperate behaviours -these add nothing to the tribunal's stature and take much away from its purposes. The conduct of any Tribunal is a question for the Chairman himself, and it is to the advantage of all if he/she insists upon the above guidelines being followed.

- 9.10**
- (a) A State Tribunal Registrar, upon receipt of the material referred to in sub-paragraphs (a) and (b) of Regulation 7.18 relating to a complaint against an official, shall formulate a notice of complaint directed to the respondent official setting forth full particulars of the nature of the complaint. The State Tribunal Registrar shall also forward a notice specifying the date, time and place for the hearing of the complaint by a Disciplinary Tribunal and shall forward the notice of complaint together with copies of the witness statements (if any) to the respondent official prior to the date nominated for the hearing of the Disciplinary Tribunal.
 - (b) If the Disciplinary Tribunal after considering all the evidence presented both by and against the official is of the opinion the official has breached any regulation or rule shall make a finding in that regard and in that case shall be entitled to impose a penalty of suspension on that official from the performance of any duties of an official for such period as the Disciplinary Tribunal considers warranted and irrespective of the provisions of regulation 6.03 to the intent that the only penalty that may be imposed on an official is the penalty of reprimand or suspension.

10.01 The Australian Motor Sport Appeal Court (AMSAC):

This Court is the final court of Appeal in respect of Karting, as administered by the AKA in Australia and is referred to in these regulations as “the Court”.

Functions:

- (i) To act as a final court of appeal after the earlier avenues of
 - (a) complaint and
 - (b) appeal to a National Appeal Tribunal have been exhausted
- (ii) To act as a third and final court of appeal for a person upon whom an AKA disciplinary tribunal or AKAC has imposed penalty, and who have, subsequent to each action, exhausted their right of appeal to an AKA Appeal Tribunal or AKAC Appeal Tribunal.
- (iii) To act as a first and final court of appeal for a person against whom the NKC has taken disciplinary action in the first instance
- (iv) To act as a court of first and final appeal for a person who claims that any ruling, direction or decision by the NKC is ultra virus or unconstitutional.
- (v) The Chairman or if he/she is unavailable the Deputy Chairman, have sole discretion to determine whether the hearing of any complaint by the Stewards of a Meeting or of an appeal by a National Appeal Tribunal has been properly held and if necessary, refer such complaint or appeal for re-hearing by the Stewards or National Appeal Tribunal (as the case may be).

10.02 Jurisdiction of the AMSAC as to Appeals:

The AMSAC shall constitute a final court of appeal empowered to settle finally any dispute arising out of or in connection with the control by the AKA of kart competitions within its territory save as specifically provided in these Rules.

10.03 Hearing of Appeals by AMSAC:

- (a) In the case of hearings by the AMSAC, all parties concerned and the AKA shall have the right to representation by advocates.
- (b) Evidence shall be given on oath or affirmation, unless the Court decides otherwise, and the giving of false evidence shall constitute an offence against these Rules punishable by at least a period of national suspension.
- (c) The AMSAC shall normally sit in Melbourne, but may, by consent of the Court and agreement between the parties concerned, sit in any other venue within Australia.
- (d) The Appellant has the right to appeal against the decision of the AKAC to AMSAC. This is subject to AMSAC time limits and rules. As laid down in the 2011 CAMS Manual of Motor Sport. Section 5: Judicial, Appendix G.

10.04 Awarding of Costs:

When giving judgement on any complaint or appeal AMSAC may make such order as to costs as it may deem fit against a person or body found guilty or unsuccessful in an appeal. Provided always no cost shall be awarded against the AKA unless the AKA itself is an unsuccessful appellant. Any delay in the payment of such costs shall entail suspension for the period during which they remain unpaid.

Preamble:

The following is a standard supplementary regulations format to be completed by “host” clubs organising race meetings. A new set of supplementary regulations must be prepared by a “host” club and approved by the relevant State Karting Council / National Karting Council before a race permit can be issued for the meeting.

Approved supplementary regulations must be made available to relevant AKA Officials and licensed competitors.

AUSTRALIAN KARTING ASSOCIATION SUPPLEMENTARY REGULATIONS

1. Authority

This meeting will be held under the International Sporting Code of the FIA, the General Standing Regulations and National Competition Rules of the AKA, and any further addendums and bulletins to the regulations.

2. Permit Number (AKA/SKS) to insert permit number when approved)

3. Organisers

Insert here the name and address and phone numbers of the organising club.

4. Date and Place of Meeting

Insert the date(s) of the meeting and the name and address of the circuit. At some circuits it may also be necessary to specify the specific track to be used and the direction of racing.

5. Officials of the Meeting (These are the minimum officials names to insert)

Stewards:

Clerk/s of Course:

Starter

Chief Timing Officer

Chief Lap Scorer

Grid Marshal

Chief Scrutineer

Scrutineer/s Technical inspector/s

Scales Marshal

Race / Competition Secretary of the meeting

Officials secretary

Tyre Tester/s

Noise Control Marshal

6. Classes to Compete

Insert the classes that events will be provided for, including the weight divisions. These must be consistent with the Karting Manual.

7. Entry

The fee for entry in each event shall be (insert amount -this may vary for each class) The date and time for close of entry shall be (insert time and date) Describe the grade of licence that will be required for competition in each class and whether provisional licence holders are eligible to enter.

8. Minimum Entries

The minimum number of entries per class shall be (insert number). If insufficient entries are received for a class, classes may be cancelled or combined at the discretion of the Organiser.

9. Format of Racing

Specify here the format of racing, including: -

Specify if standing starts are to be used for any classes.

Specify if time trials are to be conducted.

The number of heats, pre-finals and finals, including the number of laps for each.

The method for determining grid placing's for heats, pre-finals and finals.

The point system to be used.

The method for determining the winner of each event.

If the event is a "local club event" (Refer rule 1.27), use this space to clearly define any regulations applicable to the local conditions.

10. Timetable

Close of entry

Scrutineering

Official Practice

Drivers Briefing

Racing

Presentations

11. Mechanical Breakdown Lane

A mechanical breakdown lane will/will not be in use.

12. Blue and Red Double Diagonal Flag

The blue and red double diagonal flag will / will not be used during this meeting. Refer Rule 15.13.

13. Abandonment or Postponement

The organisers reserve the right at their sole discretion to abandon, postpone or cancel any event(s) subject to Rule 1.25.

14. Prizes

State here the prizes and trophies that shall be awarded.

15. Insurance

Insurance has been affected for this meeting in accordance with Chapter 3.

16. Noise Levels

Maximum permissible noise levels shall be in accordance with Chapter 24. (If a club wishes to adopt a lower noise level then the specific level in dBA shall be stated here)

The nominated judge of fact for the measurement of noise levels shall be (insert name of person). If additional noise penalties are to be applied then they should be stated here. Refer Rule 24.7.3

17. Fuel (refer Rule CHAPTER 22)

The organisers wish to inform competitors that premium unleaded fuel is not available within 40 kms of the circuit. In accordance with Rule 22.03. 3. A (ii), grade petrol may be used. (insert this clause if applicable) If a controlled fuel will be in use at this meeting, insert an appropriate statement here along with details of availability and cost. If fuel testing is to occur, advise here and the control fuel to be used.

18. Judges of Fact

List here any judges of fact that will operate at the meeting. These must only be matters that are not open to appeal under the competition rules. The Starter, The Chief Lap scorer, The Weigh Marshal, The Noise Control Marshal The Chief Timing Officer, The GC Analyst, The Grid Marshal, The Chief Scrutineer.

Background Note:

Article 65 of the International Sporting Code of the FIA, under which all competitions will be conducted, sets out the information that should be included in the Supplementary Regulations. These supplementary Regulations are to be read in conjunction with the General Standing Regulations, **National Competition Rules** and Australian Kart Formula for Sprint Racing as laid down in the current AKA Manual.

CHAPTER 12

SCRUTINEERING & TECHNICAL INSPECTION

The purpose of scrutineering is to ensure that a kart which or a driver who is competing or has competed in an event or section of an event has complied with the technical requirements of the competition regulations in relation to that event.

The technical requirements are found in the General formula, the Class formula, and in specific chapters concerned with particular subjects (eg. tyres, fuel, etc).

12.01 Scrutineering:

It is the competitors responsibility to obtain a correct scrutineering form, complete it and return it to the designated meeting official. This signifies that they have checked all listed items and their kart and apparel appear to comply with the relevant AKA Manual rules. All licence holders may be required to present their kart, apparel and scrutineering form to a scrutineer for acceptance prior to the start of the meeting.

- (a) All karts entered in any competition must be scrutineered before being permitted to take part in any practice, time trial, qualifying or race.
- (b) The purpose of scrutineering is:
 1. to ensure that any requirements specified in relation to
 - (i) fuel
 - (ii) type of tyres
 - (iii) tyre treatment
 - (iv) noise suppression equipment and
 - (v) apparel and
 - (vi) engine sealing nuts, appear to be complied with.
 2. to be satisfied that the driver complies with the age, type of licence, and weight requirements for that event
 3. to be satisfied that the driver and/or pitcrew has
 - (i) carried out an inspection and
 - (ii) prepared and signed the AKA scrutineering report form and
 - (iii) presented a kart that appears to comply with the formula.
- (c) It is not a defence to a complaint resulting from inspection after an event that the kart and driver passed scrutineering.
- (d) If the chief scrutineer's report shows that a driver or kart should be excluded from any event or section of an event on safety grounds a driver cannot lodge a complaint or appeal on that decision.
- (e) A kart which has not passed scrutineering on the decision of the Chief Scrutineer or the stewards cannot take part in the event or section of the event to which the decision relates.
- (f) The responsibility for the safety of the kart and its adherence to the rules at all times belongs to the competitor, not the scrutineer, who has absolutely no responsibility in this regard.

12.02 Inspection:

- (a) A kart or a driver may be inspected at any time before, during or after competition.
- (b) If a kart or apparel is not submitted for inspection when requested at any time by the Clerk of Course, Technical Inspector, fuel examiner, tyre examiner or noise examiner, the kart and the driver are automatically excluded from the meeting and forfeit all placings or points already gained at that meeting.

12.03 Scrutineering & Technical Inspection

- (a) The Official requesting the inspection may mark any engine part, fuel sample, accessory or apparel and require it to be presented, as directed, at the end of the meeting for further inspection and testing by a person of authority, approved by the AKA Secretariat.
- (b) The item when presented at the end of the meeting must be tagged for identification, then bagged and sealed, and a receipt given to the person presenting it.
- (c) Unless a complaint is made in respect of the item, or the AKA secretariat specifically directs in a particular case, the item (with exception of fuel sample) must be returned to the person presenting it within 21 days.

CHAPTER 13

COMPETITION DRIVER LICENCES

Preamble:

The Australian Karting Association issues, manages and records all AKA issued licences using the "AKA Licence System".

The AKA currently issues licences as either;

- a) Non-competition licences (Social Practice Only Licence) Refer to rule 13.15.1
- b) Competition Licences. Refer to rule 13.15.2, 3, 4, and 5
- c) Single Event Competition Licences. Refer to rule 13.16.
- d) CIK International Licences. Refer to rule 13.20

In order to qualify as a competitor or as a driver, any person must, except as herein after provided, be the holder of either a licence issued on the authority of the AKA or a licence recognised by the AKA.

All AKA Licence holders MUST purchase a current AKA Manual.

Notwithstanding anything in these rules the AKA/SKC may, in writing, waive the necessity for competitors or drivers to hold a licence under these Rules in order to be eligible to take part in a particular competition.

The AKA may also grant a general waiver in respect of competitors or drivers in Closed Competitions (other than race meetings) subject to such conditions as it may from time to time announce.

13.01 Application for a Licence:

To apply for the issue of a "new AKA licence" or the renewal of an "existing AKA licence", either, contact the Licence Secretary of your chosen club, or, go to www.karting.net.au, click on the "Apply for Licence" button and follow the prompts.

1. A person applying for the issue of a new licence, or renewal of an existing licence must be a member of an affiliated Club and must remain a financial member of an AKA club during that period of the licence,
 - (a) in the State in which that person is either on the Electoral Roll, or
 - (b) can prove to the reasonable satisfaction of the State Secretary that the person has resided in that State for the last three (3) months; or,
 - (c) can prove to the reasonable satisfaction of the State Secretary that the person resides within a 100 km zone when affiliated clubs are on or close to a State Boundary.
3. A person may only hold one (1) AKA licence.
4. Persons under eighteen years of age are to produce a birth certificate to the State Secretary before the issue of initial licence.
5. Persons aged 60 years or over must supply with their licence renewal application a copy of a current motorsport medical certificate. Certificate must refer to an examination undertaken within the previous three months.

13.02 Licence Card:

A plastic, photo identikit, magnetic stripe swipe card will be issued to each competitor as part of their initial licence. The magnetic stripe card simply contains the relevant AKA information and some personal information to identify the competitor. These cards will be used in conjunction with the AKA Race Management System for identification, recording, entry and / or confirmation of entry at all race meetings.

13.03 New AKA Licence:

A person who has never held an AKA licence shall, using the AKA Licence System, apply for the issue of a D Grade Provisional Licence as per rule 13.15.2.

13.04 Recognised Licences:

- 1 The AKA currently issues New Competition Licences in one of four different divisions that are age related and or experience related. All New licences are issued as either:
 1. Midgets: for persons aged from their seventh (7) birthday until the end of the calendar year of their eleventh (11) birthday. Refer to rule 13.19.1.
 2. Rookies: for persons aged from their 9th birthday until the end of the calendar year of their thirteen (13) birthday. Refer to rule 13.19.2.
 3. Juniors: for persons aged from their twelfth (12) birthday until the end of the calendar year of their sixteenth (16) birthday. Refer to rule 13.19.3.
 4. Seniors: for persons aged sixteen (16) and over. Refer to rule 13.19.4
2. The AKA currently issues International Competition Licences for the following divisions;
 - a) International Junior (under the direction of CIK Rules)
 - b) International Senior (under the direction of CIK Rules)

Applications for an International licence are subject to CIK regulations only. Drivers should apply to their State Secretary for information regarding an International licence.

13.05 Lapse of Licence:

Drivers who have allowed their licence to lapse for a period of three (3) years or more shall be regarded as applicants for a D Grade Provisional Licence.

13.06 AKA shall be entitled to grant licences to:

- (a) A subject of any territory being part of the territory of the AKA
- (b) A National of any other Country represented on the FIA after receiving authority from the ASN of that country to do so.
- (c) A National of a Country not represented on the FIA provided the FIA is first informed and makes no objection to the granting of such licence.
- (d) For an Australian Licence holder to compete in NZ they must apply to the AKA for a Trans Tasman Visa, pay a \$45.00 fee, present their licence and VISA when competing in NZ.
- (e) New Zealand competitors are eligible to compete in Australia in their relevant class subject to the competitor presenting a current Kartsport New Zealand Licence, Kartsport New Zealand Visa and Kartsport New Zealand Medical Card.

13.07 Assumed Name:

If a licence is required in an assumed name, special application shall be made to the AKA which may, if it thinks fit, issue a licence in such name. A person granted a licence in an assumed name shall not, so long as he/she holds a licence in that name, take part in any competition except under the name shown on such licence.

13.08 Period of Competition Licence/Non-Competition Licence

All competition and non-competition licences are valid for a twelve-month period from the date of issue, unless previously surrendered or withdrawn. All licence renewals will be from the anniversary date of a licence. Licences will expire after thirty days from the anniversary date of the licence, when this occurs then the licence renewal becomes a new renewal and a new licence fee will apply as per States fees. The new renewal licence date will commence when applied for and will be due for renewal on that date the following year. All licence grades will remain the same.

13.09 False or Misleading Information:

The making of false statements on the electronic forms of application for a licence or the wilful omission from such form of any information, which, if known to the AKA, might cause it to refuse such licence, shall be deemed an offence under these Rules, and shall render the licence, if issued, null and void.

13.10 Disabled Drivers:

1. The State Karting Council, with the approval of the Secretariat, may require the driver suffering from a disability to use a kart which has been modified in a manner authorised in writing by the Secretariat. The driver's licence must be so endorsed.
2. A driver suffering from a disability must produce on request a copy of the authorisation to use the modified kart.
3. Notwithstanding any other provision of the regulation, a kart so modified may only be driven by the nominated driver in an event for its class.

13.11 Responsibility of Entrant, Driver or Other:

The entrant shall be responsible for all acts or omissions on the part of the driver, mechanic, pit crew, service crew or any third party to whom his/her entry may be attributed, but each of these shall also himself be responsible for any infraction for the code, these rules, any supplementary regulations or instruction to drivers. Refer also to R 1.05.

13.12 Refusal/Withdrawal of Licence:

1. The AKA may refuse to issue or withdraw a licence without stating any reason for such refusal or withdrawal. In the case of an application for a licence coming within Rule 13.07(c) such refusal shall be notified to the FIA.
2. The Secretary may refuse to issue a licence if the fact becomes known that the applicant may suffer from a medical condition which could effect the applicant's control of the kart. In this case, the Secretary must advise the applicant that a licence will not be issued unless the applicant consents to a medical examination by a qualified doctor nominated by the State Secretary, and the doctor reports that the condition will not in his/her opinion affect the applicant's ability to control a kart. A medical examination conducted by a doctor nominated by the State Secretary shall be paid for by the State Karting Council.
3. If the Stewards of a Meeting, or the State Secretary, believe a driver suffers from a medical condition which renders the member incapable of driving safely at all times, the Stewards of a Meeting or the State Secretary, as the case may be, may advise the driver that he/she may not drive on a course controlled by the State Karting Council unless the driver is fit to drive in competition.
4. No driver who is suffering from any disability, permanent, temporary or recurrent, which may prejudicially affect the control of a kart shall take part in any event save as outlined in Rule 13.10. Any driver who has had an illness or injury which may affect the ability to drive a kart safely, must report it to the State Secretary.

13.13 Loss of Licence or Being Unable to Produce Licence When Requested:

1. All competitors must show their licence to officials when requested to do so. The Stewards of the Meeting may, at their sole discretion, enable a competitor to race without production of their relevant licence; subject to them being satisfied the competitor is the holder of a current AKA or recognised licence, as verified by the AKA Licence System.

13.14 Licence Readily Available:

Drivers are reminded that they must have their licence readily available at all times during practice and a meeting, as they will be required to produce same for checking and identification. (See rule 13.13).

13.15 Licence Grades

Within each of the four age divisions there are different grades of AKA licences with the following characteristics

1. (AKA) E Grade Social Practice Only Licence

- a) These are available to members for recreational karting. It is the minimum recommended licence for persons using an AKA Homologated recreational kart on a licenced circuit. Prior to obtaining an E Grade Social Practice Licence, a Flag Questionnaire and OLT must be completed.
- b) E Grade Social Practice Only Licence holders are only allowed to practice in equipment that they, at their age, would be eligible to race.
- c) E Grade Social Practice Only Licence holders are not permitted to take part in competition.
- d) An E Grade Social Practice Only Licence holder may be upgraded to a D Grade Provisional Licence by appropriate application and fee.
- e) E Grade licence holders must clearly display a regulation "P" plate on the rear of any kart they are driving.

2. (AKA) D Grade Provisional Licence

- a) All new applications for a racing licence will be issued as a D Grade Provisional Licence. The new driver levy will remain as \$20 (GST inclusive).
- b) Prior to competing at their first meeting, a D Grade Provisional Licence holder
 - (i) must answer the Flag Questionnaire to the satisfaction of the Stewards or the OLT Official.
 - (ii) All Senior drivers (over 18 years of age) must satisfactorily compete at three race meetings as a D Grade Provisional driver and officiate at one race meeting as a flag marshal under supervision, and have their licence endorsed after each meeting. All Midget, Rookie, Junior and Senior drivers (under 18 years of age) must satisfactorily compete at four meetings as a D Grade Provisional driver and have their licence endorsed after each meeting. Flag marshal duties are not applicable to these drivers due to age restrictions.
 - (iii) is required where practical to satisfactorily complete and pass an Observed Licence Test (OLT).
 - (iv) must ensure that their licence is endorsed when they have satisfactorily completed either parts (i) or (ii) of this regulation.
- c) D Grade Provisional Licence holders must start at the rear of the field in all events.
- d) They are not eligible to compete at:
 - (1) State Championships, or
 - (2) National Championships, or
 - (3) Temporary or street circuits
- e) D Grade Provisional Licence holders must clearly display a regulation "P" plate on the rear of any kart they are driving.
- f) All D Grade Provisional drivers must present their licence to the Clerk of Course immediately following the drivers briefing for observation during competition.

3. (AKA) C Grade Licence.

- a) To qualify for a C Grade Licence: -
 - (1) Senior Drivers must have completed the D grade requirements in 13.15.1 for upgrade.
 - (2) Junior, Rookie and Midget Drivers must have completed the D grade requirements in 13.15.1 for upgrade.

- (3) C grade licence holders are not eligible to compete at :
 - (a) National Sprint Kart Championships (bitumen).
- (4) C Grade licence holders cannot compete in the following classes:
Open Class, Formula 100, Rotax 125, Leopard 125, Junior Clubman, Jnr Rotax, Junior Performance

4. (AKA) B Grade Licence.

- a) To qualify for a B grade licence a driver shall have his/her full C Grade licence endorsed at 6 (six) race meetings as having competed satisfactorily. "P" plate signatures are not to be included in this six. Endurance karters may also obtain a B Grade licence by obtaining 4 endurance and 4 Sprint Kart endorsements.
- b) Midget B grade licence holders moving to Rookies retain their B grade status.
- c) Rookie B grade licence holders moving to Juniors retain their B grade status.
- d) Junior B grade licence holders moving to Seniors retain their B grade status.
- e) B Grade 100cc Restricted Licence, issued only to senior persons at age 15 as per 13.19.3(c) and for use in 100cc classes only.

5. (AKA) A Grade Licence.

- a) Available only to AKA Junior and Senior drivers who hold a B grade licence.
- b) To qualify for an A grade licence
Junior drivers;
 - 1) by finishing either First, Second or Third at a National Championship (Bitumen) in any junior class - automatic.
 - 2) by finishing either First, Second or Third at a State Championship (Bitumen) in any junior class - may apply to SKC.

6. (AKA) Vintage Licence.

Refer to Chapter 47 Rule 47.02

Senior drivers;

- 1) by finishing either First, Second or Third at a National Championship (Bitumen) in any championship class contested - automatic.
- 2) by finishing either First, Second or Third at a State Championship (Bitumen) in any championship class - may apply to SKC.
- c) Junior and Senior Drivers who do not meet these qualifications may apply to the SKC for consideration to be upgraded to an A grade licence.
- d) Junior A grade licence holders moving to Seniors retain their A grade status.

13.16 Single Event License

- a) Drivers whom have not held an AKA race license previously are required to do an OLT & STL. They will be issued with a "D Grade Provisional" single event license. To achieve full license accreditation (Full C Grade) they will have to comply with rule 13.18.4 (a) (i), (ii) and (iii). If the applicant has within the past three years held a full race license their previous grading will be granted for their single event license and the 3 year time limit recommences. (Rule 13.05 applies)
- b) The validity of the Single event license shall be from midnight of the last day of the race permit, for 8 days prior. This will allow for familiarity time in the kart and unofficial practice.
- c) Not valid for State or National Championships

- d) Fee: Refer to your State Association.
- e) A person applying for a Single Event Licence must apply to their relevant state Secretary via the electronic AKA Licence System.
- f) Persons aged 60 years and over must supply with their licence application a copy of a current motor sport medical certificate. Certificate must refer to an examination undertaken within the previous 3 months.
- g) The State Secretary/Licensing Officer, if satisfied that the particulars stated in the electronic application are correct and satisfy the requirement, will issue a Single Event Licence.

13.17 Licence Grading Administration:

Only one licence endorsement can be obtained per driver, per race meeting. Endorsements can be obtained at both open and closed race meetings.

Once the conditions to change a licence grade have been met, the competitor may apply to the State Secretary, via the AKA Licence System, for an upgrade.

The term Upgrade encompasses both grade changes (eg. D to C to B) and division changes (eg Midget to Rookie to Junior to Senior).

1. Drivers eligible for upgrade from National or State Championship results must apply to their relevant State Secretary, via the AKA Licence System, within twenty-one days of confirmation of the championship results.
2. Licences may also be issued by SKC under special circumstances, ie. previous motor sport experience.
3. Licences may also be upgraded by SKC refer 13.19.3 (c) and 13.15.5(c).
4. A licence holder may have his/her licence down graded at the discretion of the State Karting Council or AKA following a Steward's Report.
5. A & B Grade licence holders may elect to be downgraded to a C grade licence at anytime, but once downgraded to a C grade licence, they must remain a C grade for a minimum of 12 months.

13.18 Licence Divisions: Track Use Restrictions

The following limitations apply;

- (a) All AKA licence holders are only allowed to practice in equipment that they, at their age, would be eligible to race.
- (b) An AKA "E Grade" Practice / Recreational Licence is the minimum licence requirement for persons using an AKA Homologated kart on an AKA Licenced circuit.
- (c) Rookies and Midgets are permitted to practice and race together.
- (d) Rookies and Midgets are not permitted to practice or race with Juniors or Seniors at any time.
- (e) Juniors are not permitted to practice or race with Midgets, Rookies or Seniors at any time.
- (f) Seniors are not permitted to practice or race with Midgets, Rookies, or Juniors at any time.

13.19 Licence Qualifications, Restrictions and Options

Whenever an option to upgrade is taken under Rules 13.19 and 13.20, application must be made to the relevant State Secretary via the AKA Licence System.

1. Midget:

- (a) Any Midget driver may elect to move to Rookies at age nine (9) or at any time until the end of the calendar year of their eleventh (11) birthday. Refer rule [28.01.1](#)
- (b) They cannot advance directly to Junior Division.
- (c) Once a driver has competed in Rookies the right to return to Midgets is forfeited.
- (d) A Midget may make application to their SKC for dispensation to remain in the class for a further 12 months.

2. Rookies:

- (a) A Rookie driver may elect to move to Junior division at age 12 or at anytime until the end of the calendar year of their thirteenth (13) birthday.
- (b) Rookie drivers aged 11 years and over with a total race ready body weight (including all race wear) in excess of 55kg (verified by a Licenced AKA Official) may apply to their State Licencing Secretary for upgrade to the Junior class.
- (c) Once a driver has competed in Juniors the right to return to Rookies is forfeited.
- (d) A Rookie may make application to their SKC for dispensation to remain in the class for a further 12 months.

3. Juniors:

- (a) A junior driver may elect to move to seniors at age sixteen (16) or at any time between then and the end of the calendar year.
- (b) A Junior driver from age fifteen (15) must satisfy one of the following requirements to progress to senior status prior to their sixteenth (16th) birthday.
 - 1. Hold an International Junior Licence
 - 2. Junior A grade licence holders from age 15 must have six (6) upgrade endorsements to move to a senior A grade open / unrestricted licence.
 - 3. Junior B grade licence holders, from age 15, must obtain another six (6) upgrade endorsements noted on their licence to move to a senior restricted licence.
To gain an unrestricted senior licence, a driver must obtain another six (6) endorsements prior to their 16th birthday.
 - 4. A junior with a B grade licence, issued as per item 3 above, upon moving to senior, may elect to downgrade to a restricted 125cc C Grade licence and rule 13.17.5 applies.
- (c) Once a driver has competed in seniors, the right to return to juniors is forfeited.
- (d) To be eligible for Junior Clubman, Formula JMA or Junior Performance, a driver must;
 - (i) Be a minimum of 13 years of age.
 - (ii) Hold a B grade junior licence that has been endorsed at six (6) race meetings in a Junior National class.

4. Seniors:

Senior competitors must be minimum sixteen years of age or older unless they qualify as per rules 13.19.3(a) or (c).

- (a) Once a driver has competed in Seniors the right to return to Juniors is forfeited.

5. CIK Junior International Licence Requirements:

- (a) To be eligible for KF3 a driver must have a minimum B Grade Junior Licence with endorsements from three (3) open meetings in either Junior National or Junior Clubman Class as having reached a satisfactory standard for advancement.
- (b) To be eligible for KF3 National Championships, a driver must have an AKA A grade licence or a Junior International C licence and have conformed to Rule 13.21. 3(e)
- (c) To be eligible to compete in International Competitions a junior must hold an International C Grade Licence.
- (d) To be eligible to compete in an International Championship a junior must hold an International C grade Licence.

6. CIK Senior International Licence Requirements:

- (a) To be eligible for KF2 at state or Australian Championships, a driver must have an AKA A grade or International, B or A grade licence
- (b) To be eligible to compete in KF2 at an international Competition a senior must hold either an International C or B grade licence.
- (c) to be eligible to compete in KF2 at an International Championship a driver must hold an International B grade licence.
- (d) To be eligible for KF1 at State or Australian championships, International A grade licence or AKA KF1 grade licence.
- (i) Three endorsements on an A grade licence achieved by acceptable competition in KF2 at National Championship level; or
- (ii) By request to the CIK Committee with assessment for upgrade based upon previous karting experience and achievements.
- (e) to be eligible for KF1 at an International Competition a senior must hold either an International B or A grade licence.
- (f) to be eligible for KF1 at an International Championship a driver must hold an International A grade Licence.

13.20 International Licence Qualifications (refer Appendix B – CIK/FIA yearbook of karting)

- International Licence applicants are to have a Medical Examination by a CAMS approved Medical Officer.
- Each medical will expire with the applied licence, eg. for international licences that will be 31 Dec of each year.
- A medical is acceptable for 1 calendar month. Therefore application for a licence must be made within 31 days of the medical being signed by the doctor.
- For December 31 – Feb 28 renewals that are dispatched in November, a medical taken after 1 Nov is valid for a licence for the next year as long as it is received within 31 days of being undertaken.
 - 1. All International licensing provisions are subject to current CIK regulations.
 - 2. Junior: Ages from thirteenth (13th) birthday until fifteenth (15th) birthday.
 - (a) C Grade
 - (1) Obtain a current International medical certificate
 - (2) Hold the highest grade of National (AKA) Licence (Junior B grade)
 - (b) A Junior with an International licence may elect to move to AKA Senior Division at age 15.
- 3. Senior: Age 15 and over
 - (a) C Grade
 - (i) Obtain a current International Medical Certificate
 - (ii) hold an AKA Junior A grade licence or hold an International Junior licence or hold a Senior AKA B grade licence
 - (b) B Grade
 - (i) Classify amongst the first five (5) in at least five (5) national events and/or international events during the 24 months prior to the application. At least one (1) of these must have been obtained in a National Championship or an International Event.
 - (c) A Grade
 - (i) Must be over 15 years old at the beginning of the meeting.

- (ii) Have obtained the following results in international events during the year prior to application.
- (iii) Either he/she has been classified in the first 33% of the participants in a CIK/FIA Championship, Trophy or Cup run over a single event (if the first 33% represent more drivers than the 34 finalists of a championship, the rest of the selection of potential grade A applicants will be based on the finishing order of the second chance heat) OR
- (iv) He/she has scored points in the final classification of a CIK/FIA Championship, Trophy or Cup run over more than one event OR
- (v) He /she has been classified in the first 5 in the classification of 3 international events, subject to these results having been obtained with a grade B international licence.

13.21 For CIK classes Only: Provisional Upgrade - Upgrade B To A Licences

The National Karting council has approved a new procedure to upgrade from B grade to A grade licences.

At present the issue of an 'A' grade licence is by criteria involving placings at either State or National Championships and by 'application and recommendation' of the club and State body with final approval by the NKC.

'B' grade licence holders who apply for an AKA provisional 'A' licence must submit the application with recommendation, through their club Secretary, to the State Karting authority' who will forward the application upon recommendation' to the National Office (For National records – in case there is a problem).

The State Office is authorised to issue (on spec of the recommendation and resume) an 'A' grade provisional licence. This licence to be suitable for competition in the CIK Domestic Series. In order to confirm the provisional 'A' to a full licence . The holder will be given the following events to have the licence endorsed, to allow for full 'A' licence

- (a) All the rounds of the CIK Series (CIK classes only)
- (b) National Championship and State Championship in Formula 100 (seniors) and Junior Clubman (Juniors) ONLY.

If the 'A' Provisional applicant fails to compete at 4 of any of the events noted above in (a) & (b) as qualifying licence status events, during the current licence year then the licence grading will revert back to 'B'. The endorsements accrued to be retained on the competitors electronic licence page for records purposes only.

A new application, must be presented in the original format as described above to obtain a provisional status, the criteria must be obtained during a calendar year to obtain the 'A' status.

Eg. (Removal of Provisional).

CHAPTER 14

PROTECTIVE CLOTHING

14.01 SAFETY HELMET:

1. WEARING

- a) It is compulsory for competitors to wear a full-face helmet with a snap down visor. Safety helmets must be in good condition, with the internal liner not having any compressed or soft edges, and retention straps to have no appreciable wear or frayed stitching. The use of chin cups on helmets is not permitted. Flip up front style helmets bearing the appropriate standards are acceptable for use.
- b) Visors shall be worn at all times; it is not permitted to remove the visor from the helmet. When fitted with a spinning rain deflector, the visor may be modified to allow clear forward view but must give protection to the eyes and face at all times. Clear / night visors are mandatory for race meetings or sections of the same conducted after sunset.
- c) If prescription, corrective glasses or contact lenses are required they must be worn behind the visor and not in place of it. Lenses shall be of a plastic material with a high impact resistance and satisfactory optical properties. Glass lenses of any kind are not acceptable.

2. STANDARDS

- a) Helmets bearing the following marks are approved for use on AKA circuits
 - **AS1698** – Australian Standard,
 - **BS6658 type A, BS6658 type A/FR** – British Standards Institute, including amendments.
 - **ECE-2204 and ECE-2205** – European Standards.
 - **Snell M90, Snell SA90, Snell M95, Snell SA95, Snell SA2000, Snell M2000 Snell K98, Snell SA2005, Snell M2005, Snell K2005, Snell SA2010, Snell M2010, Snell K2010**
 - **SFI Specific 31.1, SFI Specific 31.2, SFI Specific 24.1** – U.S.A.
- b) Events on CIK International calendar will be subject to CIK Regulations.

GENERAL NOTE

A Helmet with correct standard number but which was manufactured more than 10 years ago will not be acceptable. IE a Snell M90 sticker with a manufactured date of April 1991.

3. DAMAGE

- a) If a helmet is damaged in any way then it should not be used again and a new helmet should be purchased. The driver should be notified in writing from the stewards that in the opinion of the chief scrutineer the helmet is not safe and it is recommended a new one be purchased, if it is a junior/midget/rookie, then their parent/guardian be notified.
- b) It is advised that painting or use of solvents on helmets could be potentially dangerous. Any decorations or stickers may damage the protective capacity of the shell surface and if applied should follow manufacturers guidelines and restrictions.

4. REPLACEMENT

To ensure satisfactory fit and security of your helmet –

- a) Obtain correct size by measuring the crown of your head
- b) Check that there is no side to side movement: a helmet should be as closely fitting as possible consistent with comfort
- c) Tighten chin straps securely (the chin strap must be under tension at all times); ensure therefore that the strap cannot slip.
- d) With head forward attempt to pull up the back of the helmet, ensure that the helmet cannot be removed by this method
- e) Ensure you can see over each shoulder
- f) Make sure nothing impedes your breathing in the helmet and never cover your nose or mouth other than with a flame resistant balaclava or face mask
- g) Never wear a scarf or other loose clothing that could come loose.
- h) Ensure the visor can be opened with one gloved hand
- i) Satisfy yourself that the back of your helmet provides protection for your neck.

5. MIDGETS AND ROOKIES ONLY

When the smallest helmet which offers one piece moulded full facial protection can be removed while the chin strap is correctly fastened, it is permitted to use a motor cross helmet which offers chin protection in conjunction with goggles for eye protection. Goggles should only use high impact plastic lenses to AS1609-1981 – Australian Standard or BS 4110Z – British Standard or equivalent. Including amendments.

- 14.01(a)** This rule applies to Midgets and Rookies only. When the smallest helmet which offers one piece moulded full facial protection can be removed while the chin strap is correctly fastened, it is permitted to use a motor cross helmet which offers chin protection in conjunction with goggles for eye protection.

14.02 Visor:

Visors shall be worn at all times, it is not permitted to remove the visor from the helmet. When fitted with a spinning rain deflector, the visor may be modified to allow clear forward view but must give protection to the eyes and face at all times. Clear / night visors are mandatory for race meetings or sections of the same conducted after sunset.

If prescription, corrective glasses or contact lenses are required they must be worn behind the visor and not in place of it. Lenses shall be of a plastic material with a high impact resistance and satisfactory optical properties. Glass lenses of any kind are not acceptable.

14.03 Driving Suit:

1. One-Piece Protective Clothing with full length sleeves and trousers, adequately secured at the neck, wrists and ankles shall be worn. Suits of leather, vinyl or abrasive resistant material are strongly recommended. Boiler type overalls with 'POP' type buttons are not acceptable.
2. **Any competitor shall only wear one (1) driving suit at a time**
Note: Competitors entering CIK international competitions must wear a CIK homologated driving suit.
3. Cool suits must be a fully sealed and self contained body suit, concealed inside the race suit.

14.04 Gloves:

Gloves, to the satisfaction of the Scrutineer, with full-fingered protection must be worn by all drivers.

14.05 Footwear:

Securely fastened footwear must be worn to cover and protect the ankles.

14.06 Wet Weather Clothing:

Wet-weather clothing may be worn over approved protective clothing, during wet conditions.

14.07 It is strongly recommended that all drivers wear:

- (i) Neck Brace
- (ii) Kidney Belt
- (iii) Rib and / or chest protectors.

14.08 Long Hair:

- (i) At all times when driving a kart, long hair must be retained within protective apparel.
- (ii) Drivers may use a hair net, hood, balaclava or other device to retain hair.
- (iii) Extremely long hair must be retained within the hood, balaclava and driving suit and not tucked under the helmet, in order to avoid compromising the helmet's performance in the event of an impact.

14.09 Clothing Over Driving Suit:

Any clothing worn over the driving suit must be adequately secured at the neck, waist, wrist and ankles (if applicable) and must not have any protrusions.

14.10 Weights in Clothing:

It is an offence to have any weights in a driver's clothing or on the driver's person.

14.11 Ear Protection:

1. Competitors – it is recommended to wear ear plugs in ears at all times when driving a kart.
2. Officials, Pit crew & Spectators – see R 24.8.

14.12 Pit Crew Attire:

Pit crew shall be required to wear suitable attire, including shoes, and observe any other requirements on protective clothing in these rules. This is to be the driver's responsibility – Refer R1.05.

CHAPTER 15

FLAG SIGNALS

15.01 Signal Colours:

Signals of the colours described below must only be used for purposes detailed in these Rules.

15.02 Flag Size:

Flag sizes are to be a minimum of 500mm x 500mm.

15.03 Coloured Lights:

Coloured lights may be used to substitute flag signals.

15.04 Flag Signals:

The following flag signals will be obeyed by drivers during competition or practice.



15.05 National Flag:

The National flag may be used to signal a race start.



15.06 Green with Yellow Chevron:

Restart. Reform on track. To be used by the Starter and /or Clerk of Course in the event of an error of judgement by the Starter. Can only be used prior to the first lap being completed by the race leader.

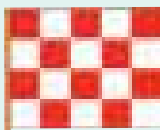

15.07 Red and White Chequered:

Signifies that it has been a false start or no start, return to pits, this flag is to be used by a Steward/ Clerk of Course or Starter prior to the first lap being completed by the race leader to enable the Stewards to take immediate action for a breach of rules prior to the start.



15.08 Yellow: Danger – Reduce Speed

Maintain position until an operational flag point that is not displaying a yellow flag has been passed. To assist following competitors and if it can be done with safety a competitor should raise one arm to indicate that he/she is slowing for the yellow flag. Failure to slow to a safe speed for a yellow flag will be considered a serious breach of these rules.



15.09 Green: (Optional)

All Clear It can also be used if necessary to signal the start of warm up laps or practice sessions, by order of the Clerk of Course (usually only used at International meetings).

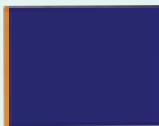

15.10 Blue: (Waved)

One or more competitors are about to lap you. You must hold your course and allow him to pass unimpeded.

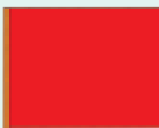

15.11 Red:

All racing shall cease. Driver will indicate by raising his/her arm and return to the grid at a greatly reduced speed and in a safe manner being prepared to stop on track if necessary. This order shall be given only through the Clerk of the Course or Steward of the meeting. Red lights may be used in addition to the red flag.



15.12 Yellow with Red Stripes: (Vertical)

Deterioration of adhesion. Informs drivers that the conditions of adhesion of the track surface have suddenly deteriorated in the area beyond the flag. This flag is most frequently used to signal that oil has been dropped on the track, but it can also be used to inform drivers of either a pool of water large enough to cause aquaplaning, or that due to a local shower drivers are about to pass from a dry to a slippery surface; that being the case, the flag will be displayed accompanied by a hand pointed to the sky. This flag shall be displayed for four laps or until the surface returns to normal. It is not necessary for the sector beyond where the flag is being shown to show a green flag.

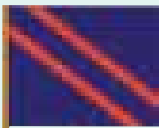

15.13 Blue and Red: (Double Diagonal) (Optional)

This flag is displayed together with a panel upon which the competitor's kart number is displayed. It will be shown to a driver who is about to be lapped or who has been lapped, the driver must stop racing, move off the racing line and return directly to the Parc Ferme. This flag may not be used unless specified in the Supplementary Regulations. A driver obeying this flag will be classed as a finisher.



15.14 Black and White with Diagonal join:

If this flag, together with a panel upon which the competitor's kart number is displayed to the driver concerned, it indicates that the competitor is being observed for unsportsmanlike behaviour. The competitor must report to the Clerk of Course or Steward immediately after the race.



15.15 Black Flag:

Should it become necessary for any reason to stop a driver, this order shall be given only through the Clerk of the Course and/or Steward of the Meeting. The black flag shall be displayed to the driver concerned, together with a panel upon which is shown the kart number. Such signal indicates that once a competitor receives the black flag they are to cease racing immediately and return to the pits next time he/she reaches it without impeding another competitor. The driver may not re-enter the race. The competitor must report to the Clerk of the Course or Steward immediately after returning to the in Grid.

15.16 Black and Orange Disc: (Optional)

This flag is displayed together with a panel upon which the competitors' kart number is shown to inform the driver concerned that their kart may have a mechanical / safety problem or does not comply with the current AKA Manual. The driver must return to the mechanical breakdown lane / in grid safely, prior to completion of the next lap. This order shall be given only through the Clerk of the Course and/or Steward of the meeting. At events where the supplementary regulations permit the use of an approved mechanical breakdown lane (as approved by the State Track Inspector) the driver may continue after repairs have been affected to the satisfaction of the Chief Scrutineer, and only under instruction of the grid marshal. Refer to rule 17.10.



15.17 White Flag or Last Lap Board:

Either a white flag or a last lap board may be displayed initially to the leading kart, and each kart subsequently, when the leading kart commences what the officials believe to be the last lap of the race.

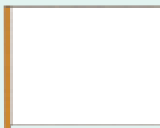

15.17 Black and White Chequered:

The display of the black and white chequered flag will determine the end of the race. The race finishing order will be as karts cross the finishing line on the lap when the black and white chequered flag is displayed. This flag shall also signify the end of practice and timed sessions. Karts that have finished the race, and cleared the Finish line safely, shall not pass karts that are still racing.

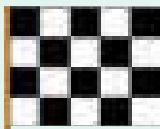

15.19 Light Signals:

It is permissible to replace/augment flag signals with light signals. For safety reasons, when using lights at flag points a flag marshal must be present, unless approved by the State Track Inspector.

(a) ROLLING STARTS:

During roll up laps an amber light may be displayed. It is optional for lights to flash if the start appears imminent. A green light will be shown to signal the commencement of racing.

(b) STANDING STARTS:

When the starter is satisfied with the grid order and the karts are stationary on the starting grid, he/she will switch on the red light. The light will change to green not less than 3 seconds or not more than 8 seconds after the red light has been switched on and the race will start.

(c) RED LIGHTS:

May be used at any point to supplement the red flag.

(d) FLAG POINTS:

At all meetings held under artificial light, each flag point must have at least one (1) battery operated Yellow warning light and one (1) battery operated Red light as approved by the State Track Safety Inspector.

CHAPTER 16

NATIONAL COMPETITION RULES

16.01 The direction of racing shall be set out in the Supplementary Regulations.

16.02 Driver's Briefing:

A Drivers' Briefing will be held prior to commencement of racing. All drivers entered must attend.

16.03 Practice and/or Carby Session

a) The Promoters (Club) must provide time for practice and/or a carby session for all competitors on their day of competition. *When circumstances permit, the Officials of the Meeting may permit practice / carby session and racing timetable to be segmented.*

E.g. At State and National Championships, practice / carby session and race timetable for the finals may be split to allow practice / carby session and racing for approximately $\frac{1}{2}$ of the total classes, followed by practice / carby session and racing for the remainder of the classes.

b) At any race meeting in any practice/carby session prior to commencement of competition for their relevant class, competitors may use any wet or dry tyres prescribed for the relevant class, any scrutineered kart that complies with chapter 25 and the relevant class chapter and any engine that complies with chapter 25 and the relevant class chapter.

c) At any race meeting in any practice/carby session after the commencement of competition for their relevant class, competitors must only use their prescribed recorded race tyres, tagged and recorded chassis and sealed and recorded engine.

16.04 Practice Discretion:

Normally in those cases where drivers do not obtain any practice, they may be placed at the rear of the grid, irrespective of any allotted grid position, or they may be excluded from the event, at the discretion of Stewards.

16.05 Lap Scoring Recording and Timing:

(a) Transponders:

1) It will be compulsory for all competitors to have an AMB TranX160 transponder fitted to their karts for the purposes of lap timing and / or lap scoring recording in all qualifying sessions and competition, in conjunction with the AKA Race Management System, at race meetings.

(b) Fitting, Maintenance and Operation:

Competitors will be responsible at all times for the correct fitting (rule 25.30), maintenance and operation of the transponder in all sections of events contested. Competitors who fail to comply with this rule will be automatically excluded from the section of the event to which the offence relates, unless rule 16.05 (d) applies, or, the fault is with the organisers of the event. Action will be taken by the issue of a Penalty Notification Form which will be issued without an Officials Hearing and signed by at least one Steward and the Chief Timing Officer (Judge of Fact). *If the transponder fails during the competition due to a technical fault as a result of "force majeure", a Judge of Fact will take effect.*

(c) Timed Qualifying Sessions:

- 1) For events or specific races that require timed qualifying to determine grid positions (other than State or National Championship events), the organizers may program a minimum of one or a maximum of two timed qualifying sessions per class. Each programmed timed qualifying session must allow competitors a reasonable time to complete a minimum of three (3) timed laps and shall be no more than five (5) minutes in duration.
- 2) Timing for each qualifying session will commence when the first kart crosses the timing loop. The chequered flag will signal the end of the qualifying session and will be shown after the designated qualifying session time has elapsed. Competitors will continue to be timed until the completion of their lap.
- 3) The fastest single lap for each driver, from all sessions, **for each class**, will determine their respective grid positions for their event. In the event of a tie, the next fastest lap will determine the grid position. In the event of a further tie, grid positions will be determined by a rerun of a timed session for those affected by the tie, over a maximum of three timed laps.
- 4) Any competitor who fails to register a qualifying time or fails to complete a minimum of three timed laps is not eligible for a re-run unless in the opinion of the Stewards, the organisers were at fault.
- 5) Any competitor who fails to register a qualifying time or fails to complete a minimum of three timed laps as the result of a fault of the organisers, must be given a replacement timed qualifying session of equal duration. Replacement timed qualifying sessions will be scheduled at the end of the programmed timed qualifying sessions and may consist of competitors from other class divisions of similar performance, the exception being the combining of prohibitive classes ie Midgets / Rookies, Juniors and Seniors.
- 6) The first timed qualifying session per class may be run simultaneously with practice / carburettor sessions when noted in the Supplementary Regulations for the meeting.

(d) Failure to Register a Qualifying Time:

- 1) When a competitor fails to record a time in any timed qualifying session for any reason other than through the fault of the organisers, the driver will be issued a time of the slowest lap time from that session, plus one second. Action will be taken by the issue of a Penalty Notification Form which will be issued without an Officials Hearing and signed by at least one Steward and the Chief Timing Officer (Judge of Fact). A complaint / appeal cannot be lodged against this action.
- 2) Where more than one competitor has received a penalty of the slowest lap time plus one second for any reason, they shall be placed on the grid at the rear of the field in an order determined by random draw.

(e) Underweight:

If a competitor is deemed to be underweight in a Timed Qualifying Session they shall receive a time penalty of the slowest qualifying lap time for their class plus one second. Action will be taken by the issue of a Penalty Notification Form, which will be issued without an Officials Hearing and signed by at least one Steward and the Scales Marshal (Judge of Fact). A complaint / appeal cannot be lodged against this action.

(f) Weaving:

Weaving, or rapid changes of direction at any time after leaving the out-grid during timed qualifying sessions are prohibited. Drivers will be penalised with a time penalty of the slowest lap time plus 1 second for that session. Action will be taken by the issue of a Penalty Notification Form which will be issued without an Officials Hearing and signed by at least one Steward and the reporting Official (Judge of Fact).

A complaint / appeal cannot be lodged against this action.

16.06 Consolidation of Classes:

For events other than a State and National Championships.

- (a) Senior Classes may be run co-jointly as long as track density rule is not breached.
- (b) Junior Classes may be run co-jointly as long as track density rule is not breached.
- (c) Midget and Rookie classes may be run co-jointly as long as track density rule is not breached. Midgets will be gridded to the rear.
- (d) When classes are run co-jointly, provisional licence holders must start at the rear of the entire field in all events. Refer definition Chapter

16.07 System of Gridding:

- (a) The Grid Marshal shall call all competitors to the grid and will allow two minutes for all grid positions to be filled. In the event of a grid being left open at the end of two minutes the vacancy shall be filled by the next qualifying competitor.
- (b) A driver who has qualified for pole position can select which side of the grid he/she wishes to start from and second pole will assume the opposite position. This does not alter any other grid positions. Pole position to wear a fluoro armband or other form of identification.
- (c) A two-minute board is to be displayed at the Grid gate the moment the first kart leaving the grid has crossed the baulk line. Karts are allowed up to two minutes to clear the grid. If the grid is cleared before two minutes the board is lowered and the drivers are then placed in the hands of the starter, the Grid gate will be closed. Once the grid gate is closed, any karts still on the grid will be deemed non-starters for that race.
- (d) At temporary circuits the supplementary regulations, the stewards of the meeting or the track inspectors can stipulate that an inline start will be used. If this is specified a single line formation in grid order must be maintained until the starting signal is given. Pole sitter will be responsible for setting a reasonable speed in the roll up laps. This rule will not alter starting procedure as Rule 16.09 or in Rule 16.11.
- (e) Clutch driven engines must not be started until directed by the grid marshall. The driver must be in the kart when starting the engine, and the drive wheels must remain stationary. When the grid gate is opened, the grid marshall will instruct the drivers to exit the grid in an orderly manner. Any kart unable to proceed when instructed to do so is to be moved aside by the pit crew, as instructed by the grid marshall, to allow karts behind it to exit the grid. Karts moved aside under this rule are allowed 2 minutes under rule 16.07(c).

16.08 Starting Time:

The starting times for racing will be shown in the official programme.

16.09 Starting:

Le Mans type starts are forbidden.

The Starter shall, from the moment the drivers come under "Starters orders" until he/she has given the starting signal, fulfil all duties of Clerk of Course.

- (i) Rolling Starts: Driver must maintain his/her grid position until the starting signal has been given. Failure to do so may incur a penalty. The Starter will be in a position near the starting area. A driver not in his/her correct grid position should signify by raising his/her hand above his/her head. Hands raised unnecessarily will incur a penalty. The field will complete approximately one full formation lap before the start signal will be given. It is the driver's responsibility to retain his/her grid position and the Starter is not obligated to allow any additional formation lap to allow a driver who has lost his/her place to regain it.
- (ii) The practice of weaving to warm tyres during the first rolling lap is permitted except when timed qualifying sessions are used. The first rolling lap will be terminated as karts pass the grid apron the first time including when short circuits or roll up cut off areas are used unless the track licence defines otherwise.
- (iii) The driver on pole position, under direction from the Starter or Clerk of the Course shall set the speed at which all competitors shall approach the starting area in anticipation of a start signal.
- (iv) The starter will give the start signal as soon as he/she is satisfied with the formation. It is forbidden for drivers to accelerate until the front row of karts have crossed the yellow acceleration line painted on the track surface or the start signal has been given, whichever occurs first.
- (v) All tracks are to have a "no mans land" marked on the track immediately before the starting area. Any kart entering this section of the track before the starting signal is given may be penalised.
- (vi) In the event of karts breaking formation before the start of a race or not complying with the requirements of Rule 16.09 or Rule 17.07 the event may be stopped at the discretion of the Starter and/or the Clerk of Course/Stewards. The offending driver or drivers may be penalised after the red and white flag is used to return the class to the grid. Continued offences will lead to exclusion. The effect of giving notice of appeal does not apply to Rule 16.09.
- (vii) Standing Starts: Karts will receive two (2) warm up laps, all karts must be stationary in proper grid order until starting signal is given. A driver whose kart stalls must raise one arm as a signal to warn other drivers. The start signal will be given within ten seconds of all karts becoming stationary. Once all other karts have left the grid any stalled karts may be restarted by persons authorised by Clerk of Course.

16.10 Restarting of Karts:

The following requirements apply to all karts and competitors:

- (a) The restarting of a kart engine during racing is not permissible except from the mechanical breakdown lane or as references in 16.10(e) (refer breakdown lane rule 17.10)
- (b) The restarting of a kart by a Midget, Rookie or Junior during practice is not permissible
- (c) In the event of a spin or collision during the rolling laps prior to the Start:-

- (i) Midgets, Rookies and Juniors are permitted to be restarted with the assistance of delegated persons at the discretion of the Grid Marshall, Clerk of Course or Steward.
 - (ii) Seniors may restart themselves however outside assistance to push karts by delegated persons (maximum 2) may be permitted at the discretion of the Grid Marshall, Clerk of Course or Steward.
- (d) Before the start of a race, delegated persons (1 per competitor and not an official) may assist a driver to repair, alter or adjust their karts in the track area.
- (e) Karts fitted with clutches: In the event of a spin or stoppage on the track, karts fitted with clutches may continue racing provided always that:
- (i) The driver remains seated in the kart at all times.
 - (ii) The driver does not touch the ground with either their hands or feet.
 - (iii) No other person has lifted, pushed or directly moved the kart to get it mobile.
 - (iv) The kart proceeds with its own power.
 - (v) Only karts fitted with an onboard electric starter may restart the engine.
 - (vi) The kart proceeds as soon as safely possible to the direction of racing and within 1 lap.
- The above sub-points are not applicable to endurance racing.
- (f) The Starter is not obliged to allow any additional formation lap to allow a driver who has lost his/her place to regain it.
- (g) During racing delegated persons may assist in the removal of karts from the race track and to a place of safety.

SAFETY NOTES

- **Delegated persons must retire to a safe position once the race has commenced.**
- **During racing Flag Marshal Assistants may remove stationary karts from the track**

16.11 Race Stoppage:

Races may only be stopped under extreme emergency and by using the red flag/lights.

- (a) When a race is stopped it must be restarted over the remaining number of laps as approved by the Stewards, unless
- i. It is at least 50% complete at the time. In this case places will be awarded according to the position at the end of the lap prior to race cessation.
 - ii. It is a State or National Championship event where less than 3 laps remain to be completed. In this case places will be awarded according to the position at the end of the lap prior to race cessation.
- (b) Any competitor who is stationary when red flag is used to stop a race will not be permitted in the re-start of that race. There shall be no complaint or appeal against this rule.
- (c) After a red flag incident, the karts are to be impounded in "parc ferme" and no work is permitted to be carried out. Any karts found by the Scrutineers to be unsafe and / or non compliant will be excluded from the re-start of the race.

(d) Re-Start of Race:

- (1) Positions to be as last recorded lap. If the lap scorers do not have a complete record of all starters, the Stewards may re-start the race in the original order with grid positions revised after exclusion of those who are ineligible under Rule 16.11(b).
- (2) If the race is stopped on the first lap, the race is restarted in the original grid order and formation after the exclusion of those who are ineligible under Rule 16.11(b).
- (3) **If a re-start is to be conducted over laps remaining, such a re-start is to be in single file at a pace as directed by the Clerk of Course. The starter must allow all karts to be clear of the out-grid and in formation, if necessary allowing roll-up laps of the circuit, before the starter signifies the re-start of the race.**
- (4) All competitors eligible for a re-start after a red flag stoppage must be allowed one spark plug change if the engine fails to fire after the first attempted re-start. Subsequent attempts will be allowed at the discretion of the Clerk of the Course.

16.12 Race Distance Alteration:

- (a) The Stewards or Clerk of Course may shorten a race by advising the Starter to display a chequered flag to terminate the heat or race if only one kart is left racing.
- (b) The Stewards and the Clerk of Course may **reduce or** extend the laps/heats if changing circumstances permit.

16.13 Win By Default:

If only one kart faces the Starter in readiness to start, in any race, due to a breakdown or withdrawal of other competitors, then he/she shall be deemed to have won the race by default. Subject to one heat being completed.

16.14 Winner Of Draw:

In the circumstances of a draw, the winner is to be determined by a count back system as follows: The winner to be the competitor who has scored the highest number of first placings, then the highest number of second placings and so on throughout the relevant event. Should there still be a tie (with placings checked), winner to be the competitor with the fastest qualifying time trial. If time trials or timed practice are not conducted the winner will be determined by the higher placing in the final race of the event.

In the circumstances where there is a draw for a grid position for a heat then the grid position for that heat will be determined by a random draw.

16.15 Kart Direction:

During an event, it is expressly forbidden to drive or push a kart at any time in a direction opposite to that in which the event is being run. Infringement of this rule means immediate exclusion and possible further penalty, except as in R16.10 (e)(iii). Should any club be found to allow use of their track in the direction that is not approved the matter is to be referred to the SKC for penalty.

16.16 Stop On Course:

If for any reason a driver is forced to stop his/her kart on or near the course, it will be his/her duty to place it in such a manner as to cause the least danger or obstruction to other competitors.

16.17 Stalled Kart:

Any driver whose kart stalls at the start of or during an event must hold one arm vertically above his/her head as a warning to the other drivers. No person may approach the kart until the remainder of the starters have passed. If necessary, the kart may be removed from the track by the driver or officials.

16.18 Rejoining Circuit:

It is forbidden to use any route other than the track used for the race to gain/regain a place. Any competing kart having left the course with all four wheels shall.

- i) rejoin the course at the nearest point of exit from it with relative safety.
- ii) not rejoin the course until safe to do so.
- iii) Should a kart rejoin a race having gained an advantage in position, distance or time of where they were when they left the circuit, they must regain their position within one lap (from the point where they re-joined the circuit).
- iv) If during the last lap of a race, any competing kart having left the course with all four wheels, arrives at the chequered flag without having redressed their advantage prior to where they were when they left the course, the competitor may be penalised.

16.19 Lapping Competitor:

When a driver is preparing to lap another competitor the driver of the kart to be overtaken must hold his/her course and allow the lapping kart to pass unimpeded.

16.20 Wearing Safety Apparel:

If a driver is involved in an accident/incident and cannot retreat behind a protective barrier during competition the driver must leave all of his/her safety apparel on.

16.21 Observed Driving:

Stewards and/or Clerk of the Course have the right to submit any driver to official practice laps for observation and have the right to decide whether or not any driver reaches such standards as they may deem necessary.

16.22 Injured Driver Clearance:

Any driver who is injured or appears to be injured, can be instructed by the Stewards or Clerk of Course to obtain a clearance in writing from the appointed first aid officer, ambulance officer or doctor and present his/her clearance to the Chief Steward. The Stewards will then decide whether the driver can take part in the race meeting. There shall be no complaint or appeal against the Stewards' decision in this matter.

16.23 Contact of Karts:

- (a) A driver who causes a kart to make contact with another kart may be penalised.
- (b) A driver who drives or acts in a manner that could endanger themselves or any other persons may be penalised.

16.24 Ducking Head:

Drivers ducking their head in a manner that will impede forward vision will be penalised.

16.25 Shaking Hands:

Drivers shaking each other's hands, whilst driving, shall be penalised.

16.26 Finishing Under Power:

A kart must complete the Course under its own designed motive power. A kart could coast over the line without manual assistance and be classed as a finisher provided he/she receives the Finishing Flag.

16.27 During a race:

- 1) A kart alone on the track may use the full width of the track. However, as soon as it is caught up on a straight line by a kart which is either temporarily or constantly faster, the driver shall maintain his/her line.
- 2) Curves, as well as the approaches and exit zones thereof, may be negotiated by drivers any way they wish within the limits of the track. Overtaking may be done either on the right or the left. However, manoeuvres liable to hinder other drivers, such as premature direction changes, deliberate crowding of karts towards the inside or outside of the curve or any other abnormal braking or changes of direction, are strictly prohibited and shall be penalised according to the importance and repetition of the offence.

CHAPTER 17

CIRCUIT SAFETY REGULATIONS

17.01 Club Safety Officers

Each Club is to appoint a Club Safety Officer to be responsible for circuit safety. Club Safety Officers are to liaise with the State Track Inspector. It is recommended that the officer is not a member of the Club Executive.

17.02 Annual Inspection

The complex will be inspected annually by the State Track Inspector, prior to approving the issue of the circuit licence. Circuits will also be inspected following any track alterations before the issue of an amended circuit licence.

It will be the responsibility of the State Track Inspector to assess existing circuits on their merit and to advise each club with the necessary upgrading over a period of time (if necessary) to the required safety standard. The circuit licence is to be displayed in the Stewards Room and be maintained in a legible condition.

17.03 Circuit Maintenance

(i) Routine Circuit Maintenance

It is the responsibility of stewards to check that normal routine maintenance has been carried out prior to race meetings. In the event that the circuit conditions are not satisfactory stewards will stop racing until the circuit is to their satisfaction, and report their action to the Club Safety Officer/Club Representative and the State Karting Council.

(ii) Stewards Report

The Stewards and the Clerk of the Course are to complete a circuit inspection report, as part of the Stewards Report, prior to the commencement of competition.

(iii) Complex Log Book

Each complex is to have a duplicate logbook, to be filled out at every race meeting with the duplicate attached to Stewards report, for comments or recommendations on safety upgrades or maintenance by the state track inspector, stewards, clerk of the course or club officials. This logbook is to be kept in the race secretary's office or stewards' room.

17.04 Baulk Line

The baulk line signifies the limit to which a kart may be pushed. Before a kart crosses this line it must be operating under its own motive power. A kart that is pushed past the baulk line may be penalised, as determined by the stewards. This rule is not negated by rule 16.10.

17.05 Reaching Baulk Line

Karts that fail to start or need to be restarted before reaching the baulk line must be immediately removed from the track or returned to the grid apron to try again. Before trying again the competitor must get permission from the grid Marshal or Clerk of Course. Only one additional attempt to restart will be permitted. Offenders will be penalised as outlined in Chapter 6.

17.06 Acceleration Line

When karts are approaching the start line in anticipation of a start, it is forbidden for drivers to accelerate until the front row of karts has crossed the acceleration line.

17.07 No Mans Land

Any kart entering this section of the track before the starting signal is given may be penalised. (Refer Rule 16.09(V)).

17.08 Start Line

The start line is the primary control line.

17.09 Finish Line

The finish line is the final control line. The order in which karts complete a race will be judged to this line. In the case of timed qualifying using electronic means, the start and finish lines will be replaced by the beams or timing loops.

17.10 Breakdown Lane

- (1) It shall be permissible for a kart to drive to this area for repairs during practice, roll-up laps and racing and to rejoin the race/practice, under the instruction of the grid marshal. The drivers may receive assistance for repairs and restarting while in the breakdown lane. This area may be subject to parc ferme control and karts will be restricted in their speed in the breakdown lane.
- (2) When a kart returns to the breakdown lane for mechanical repairs, during the start procedure it may rejoin the race even after the start is given. The kart may only re-enter the race with safety and under the given direction of the grid marshal. Where the start line extends across exit from the breakdown lane, a kart that has come under starters orders, may start (commence their first lap) in the breakdown lane.
- (3) Stopping in the deceleration lane is strictly forbidden.
- (4) The breakdown lane cannot be used during an event unless specified in the supplementary regulations.

17.11 Parc ferme /Paddock:

1. Parc Ferme

This area will come under control of the parc ferme marshal

- (a) Fuel is to be stored in appropriate containers and kart engines are to be stopped before refuelling.
- (b) No cars or trailers will be permitted by the parc ferme Marshall
- (c) Smoking, welding or use of any open flame is not permitted in parc ferme area.

2. Paddock area

All karts will come under control of the Paddock marshal

- (a) All karts shall be accommodated within the defined paddock area whilst not competing during meeting
- (b) It is forbidden to drive a kart inside the boundaries of the paddock area enclosure for any reason whatsoever.
- (c) Fuel is to be stored in appropriate containers and kart engines are to be stopped before refuelling
- (d) Kart trailers and specialized vehicles are allowed in the paddock enclosure to enable competitors to work from, and subject to supplementary regulations of the meeting and instructions from the paddock marshal.

- (e) The use of cycles, skateboards, scooters etc, are not permitted during the life of the race permit in the area known as the paddock.
- (f) Smoking, welding or use of any open flame is not permitted within the paddock.
- (g) All persons must hold a valid (Government issued) driver's licence to drive a registered motor vehicle within the perimeter of any AKA licensed premises. The minimum penalty for a breach of this rule will be exclusion from the race meeting, 3 months kart licence suspension and possible further penalty.

17.12 Safety of Karters and Officials:

All officials must remain behind protective barriers at all times during racing. The only people permitted inside the circuit area whilst karts are racing are:

- (a) Flag Marshals - maximum two per point. (for National and State Championships two flag marshals per point are required)
- (b) Starter/Assistant
- (c) Stewards
- (d) Clerk of the Course
- (e) Medical Attendants
- (f) Authorised persons to assist drivers.
(NOTE: These persons must retire to a safety area once the race has commenced).
- (g) Photographers and other persons (in designated areas at the discretion of the Clerk of the Course/Stewards).
- (h) The Clerk of the Course or Stewards may, if necessary, observe racing from a safe location even though a tyre barrier may not be in that location. The time spent in this location must be no longer than necessary.
- (i) In the absence of a specified protected area, Stewards must remain behind flag marshal protection whilst karts are in motion.
- (j) A minimum dress standard of an AKA Orange vest must be worn by all Race Officials listed on the Supplementary Regulations who need to enter the race circuit, except for flag marshalls who shall wear an AKA official green/yellow vest. Anyone else entering the race circuit must wear a non AKA green/yellow vest.

17.13 Head sets and communication

- (a) It is a requirement of the permit that at State and National Championships that the following officials are supplied with head sets and communication – Clerk of Course (or Director), Stewards of the Meeting, Chief Scrutineer, and Scrutineers, Scale Marshals, Flag Marshals, Starter, Grid Marshals, Lap Scorers and Medical Attendant.
- (b) It is a requirement of the permit that at all race meetings that the following officials are supplied with head sets and communication – Clerk of the Course, Stewards, Starter, Grid Marshall and Scales Marshall and recommended for all other officials.

17.14 Smoking and Welding

Smoking, welding or use of any open/naked flame, or heating guns/heating devices is not permitted in the circuit, parc ferme or paddock/pit areas at any time.

17.15 Cleaning Fluid

The only flammable material permitted for cleaning in the Paddock Area is KEROSENE.

17.16 Alcohol and Drugs

Alcoholic liquor, illegal or other drugs (see Rule 1.33) are not permitted in the grid, parc ferme or paddock areas. Penalty for this offence will be exclusion of the relevant driver and pit crew.

17.17 Temporary Circuit Guidelines:

For information referring to Temporary Circuit requirements, contact the relevant State Karting Council. The AKA recognises that it is not possible to construct temporary circuits in full conformity to the rules of Chapter 18, refer www.karting.net.au however the safety rules will be used as a guide for the construction of these facilities.

Night temporary street circuit meetings may only be conducted if the track and lighting can be inspected by the State and Interstate Track Safety Officers at least three months prior to the event. Failure to pass at this inspection will be sufficient cause to cancel the meeting.

All inspection costs are to be the responsibility of the promoters.

- (i) Promoters shall, at least sixty (60) days prior to the date of the Meeting, furnish the State Secretary with three copies of the proposed Supplementary Regulations (for transmission to the AKA) including names of all Officials, a detailed plan of proposed temporary circuit, together with the appropriate fee. (Refer Chapter 2 of this Manual). Supplementary regulations and entry forms are not to be issued until the approval of the AKA (through the State Secretary) is given. For previously approved circuits with no changes to track configuration, safety barriers or approved classes, plans are not required to be submitted with the application.
- (ii) The application from the promoting club must include the specific classes to be run. SKC approval will depend on the circuit safety for competitors and spectators and the State Track Inspector's opinion.
- (iii) A preliminary permit will be issued pending final circuit inspection and approval given by the Track Inspector(s) for the official permit to be put into place on the day of the event. Track Inspectors are to endorse Permit on approval of the temporary circuit.
- (iv) At least one (1) Interstate Track Inspector must be present for the duration of the event and for the supervision and construction of the event's circuit.
- (v) The Interstate Track Inspector, in conjunction with the State Track Inspector, has the power to licence the temporary circuit, authorise that the track is satisfactory for the commencement of competition, require variations to the circuit and to stop the competition at any time.
- (vi) Expenses associated with accommodation, meals, travel, etc. for the Interstate Track Inspector are to be paid by the Promoting Club. 50% of the travel expenses for the Interstate Track Inspector will be paid by the AKA.
- (vii) Competitors competing at an Open Meeting on a temporary circuit must be a minimum 'B' Grade licence holder AND have an endorsement in their licence / log book to indicate that they have competed previously at an Open meeting in the class for which they have nominated to compete.
- (viii) All corners and chicanes must have kerbing on the inside and be such that a kart can run over it and continue in a safe manner.

17.18 Track Density/Maximum Number of Starters

| Track Length (Metres) | Track width at narrowest point | | |
|--------------------------|--------------------------------|----|----|
| | 6m | 7m | 8m |
| <500 | 20 | 22 | 24 |
| 500 - 625 | 22 | 24 | 26 |
| 626 - 750 | 24 | 26 | 28 |
| 751 - 875 | 28 | 30 | 32 |
| 876 - 1000 | 32 | 34 | 36 |
| > 1000 | NA | 38 | 40 |

At Executive Direction, the National Track Safety Coordinator has the authority to reassess a track as to the number of karts eligible for competition on a track.

Track Density/Maximum number of starters:

The National Track Safety Coordinator, in consultation with the National executive has the authority to reassess a track as to the number of karts eligible for competition on a track.

CHAPTER 18

EVENT RACE FORMATS

Preamble:

The following race formats have been programmed to suit the AKA Competition Management System to run Championship style race meetings. This chapter sets out the rules governing under-subscribed classes, and provides for three options for governing over-subscribed classes, dependant on the number of over-subscribed entries.

18.01 UNDER-SUBSCRIBED CLASSES: UP TO TRACK CAPACITY.

(2 x timed qualifying, 2 heats, pre-final and final)

- (a) **Timed Qualifying** Timed Qualifying to be as per rule 16.05(c) 2), 3), 4) & 5) 2 x 4 minutes qualifying sessions. First qualifying session, lowest kart number to grid 1 and so on. Second qualifying session, highest kart number to grid 1 and so on.
- (b) **Heats** Heat 1; Grid positions as per qualifying, fastest time to grid one, and so on.
To be run over a distance of 7km minimum.
Heat 2; Grid positions as per qualifying, fastest time to grid one, and so on.
To be run over a distance of 7km minimum.
- (c) Point Score System for Heats:
1st - 0 Points
2nd - 2 Points
3rd- 3 Points and so on with one point being added for each place.
Non-starters and non-finishers to be awarded a finishing position based on the number of laps completed, then the grid position awarded from the start of the heat.
- (d) **Pre-final** One pre-final. Lowest accumulated points from heats one and two to grid one, and so on. Pre-final to be run over a distance of 11km minimum. **In the event of a tie on points, the lower grid position will be awarded to the driver with the faster original timed qualifying.**
- (e) **Final** One Final: The finishing order from Pre-Final determines grid positions for the final. Winner of pre-final to grid 1, second to grid 2, and so on. Non finishers in the pre-final will be gridded at the rear of the field in order of laps completed, then grid position from pre-final. Final to be run over a distance of 16kms. minimum.
Finishing order of the final determines the winning positions in each Championship Class.
- (f) All competitors must register a qualifying time and compete in the first heat to be eligible for grid positions for the Pre-Final and the Final.
- (g) Karts underweight will be excluded as per rule 5.03.2, except during timed qualifying when rule 16.05(e) applies.

18.02 OVER-SUBSCRIBED CLASSES: GREATER THAN TRACK CAPACITY.

The race format for over-subscribed classes will be dependent upon the number of entries received over track capacity.

Race Format 1 (optional) may be used for over-subscribed classes < or equal to 110% of track capacity.

Race Format 2 will be used for over-subscribed classes < or = to 150% of track capacity.

Race Format 3 will be used for over-subscribed classes > 150% of track capacity.

The maximum number of entries that can be accepted for any class will be an amount equal to twice the track capacity.

18.03 RACE FORMAT 1:

OVER-SUBSCRIBED CLASSES < OR EQUAL TO 110% OF TRACK CAPACITY.

(Qualifying, Repechage, 2 heats, pre-final, final.)

- (a) **Timed Qualifying:** Timed Qualifying to be as per rule 16.05(c) 2), 3), 4) & 5) 2 x 4 minutes qualifying sessions.
Over-subscribed classes will be split into two qualifying groups by the Chief Timing Officer, based upon their race numbers. First qualifying session for the class, group 1 will precede group 2, both groups with lowest kart numbers to the front. Second qualifying session for the class, group 2 will precede group 1, both groups with highest kart numbers to the front. After timed qualifying sessions, all but the last five (5) grid positions (up to track capacity) are filled immediately for the heats, with the fastest qualifier from either group to grid 1, the second fastest qualifier from either group to grid 2, and so on. The last five (5) grid positions for the heats are filled from the results of a REPECHAGE RACE between the remainder of the competitors in the class.
- (b) **Repechage:** One repechage - grid positions as per qualifying (faster time to grid position one, and so on). Repechage to be run over a distance of 11kms minimum. Competitors who fail to qualify for a starting position in the heats will be eliminated and refunded 50% of their entry fee. No refund on tyres.
- (c) **Heats:** Heat 1 - grid positions as per qualifying (fastest time to grid position one, and so on) including first five place getters from repechage race.
To be run over a distance of 7km minimum.
Heat 2 - grid positions as per qualifying (fastest time to grid position one, and so on) including first five place getters from repechage race.
To be run over a distance of 7km minimum.
- (d) Point Score System for Heats:
1st - 0 Points
2nd - 2 Points
3rd - 3 Points and so on with one point being added for each place.
- (e) Non-starters and non-finishers to be awarded a finishing position based on the number of laps completed, then the grid position awarded from the start of the heat.
- (f) **Pre-final:** One pre-final. Lowest accumulated points from heats one and two to grid one, and so on. To be run over a distance of 11km minimum.
In the event of a tie on points, the lower grid position will be awarded to the driver with the faster original timed qualifying.
- (g) **Final:** One Final: The finishing order from Pre-Final determines grid positions for the final. Winner of pre-final to Grid 1, second to grid 2, and so on. Non finishers in the pre-final will be grided at the rear of the field in order of laps completed, then grid position from pre-final.
Final to be run over a distance of 16kms minimum.
Finishing Order of the final determines the winning positions in each Championship Class.
- (h) All competitors must register a qualifying time and compete in the first heat to be eligible for grid positions for the Pre-Final and the Final.
- (i) Karts underweight will be excluded from the relevant section of their event as per rule 5.03.2 except during timed qualifying when rule 16.05(e) applies.

18.04 RACE FORMAT 2:

OVER-SUBSCRIBED CLASSES < OR = TO 150% OF TRACK CAPACITY.

(2 x timed qualifying, 2 heats, pre-final, final.)

- (a) **Timed Qualifying** Timed Qualifying to be as per rule 16.05(c) 2), 3), 4) & 5)

2 x 4 minutes qualifying sessions.

Over-subscribed classes will be split into two qualifying groups by the Chief Timing Officer, based upon their race numbers.

First qualifying session for the class, group 1 will precede group 2, both groups with lowest kart numbers to the front.

Second qualifying session for the class, group 2 will precede group 1, both groups with highest kart numbers to the front.

After qualifying, drivers will be split into 3 groups, A, B, or C

Fastest qualifier to group A, 2nd fastest to group B, 3rd fastest to group C, 4th fastest to group A, 5th fastest to group B, 6th fastest to group C, etc until all drivers are allocated a group.

- (b) **Heats:** Each group will race against each other group over two heats.

Fastest qualifier (1st in A group) will race from pole position in the 2 heats.

2nd fastest qualifier (1st in B group) will race from pole position in 1 heat.

Heats to be run over a distance of 7 kms minimum.

Heat A - Group A v's C (grid as per qualifying order)

A's grids 1, 3, 5, 7, etc, C's grids 2, 4, 6, 8, etc

Heat B – Group B v's C (grid as per qualifying order)

B's grids 1, 3, 5, 7, etc, C's grids 2, 4, 6, 8, etc

Heat C – Group A v's B (grid as per qualifying order)

A's grids 1, 3, 5, 7, etc, B's grids 2, 4, 6, 8, etc

- (c) Point Score System for Heats:

1st - 0 Points

2nd- 2 Points

3rd- 3 Points and so on with one point being added for each place.

- (d) Non-starters and non-finishers to be awarded a finishing position based on the number of laps completed, then the grid position awarded from the start of the heat.

- (e) **Pre-final** One pre-final. Grid positions for the pre-final will consist of the lowest points scorer from the heats to grid one, second lowest points scorer to grid 2, and so on until the grid is filled to track capacity. In the event of a tie on points, the lower grid position will be awarded to the driver with the faster original timed qualifying.

In the event of any withdrawals from the qualified capacity grid for the pre-final, competitors will be moved up and vacant grids filled with the next available qualifier, up to track capacity.

To be run over a distance of 11km minimum.

- (f) **Final** One Final: The finishing order from Pre-Final determines grid positions for the final. Winner of pre-final to grid 1, second to grid 2, and so on. Non finishers in the pre-final will be gridded at the rear of the field in order of laps completed, then grid position from pre-final.

Final to be run over a distance of 16kms. minimum.

Finishing order of the final determines the winning positions in each Championship Class.

- (g) All competitors must register a qualifying time and compete in one heat to be eligible for a grid position in the pre-final and final.

- (h) Karts underweight will be excluded from the relevant section of their event as per rule 5.03.2, except during timed qualifying when rule 16.05(e) applies.

18.05 RACE FORMAT 3.

OVER-SUBSCRIBED CLASSES > 150% of track capacity.

(2 x timed qualifying, 3 heats, pre-final, final.)

- (a) **Timed Qualifying** Timed Qualifying to be as per rule 16.05(c) 2), 3), 4) & 5)

2 x 4 minutes qualifying sessions.

Over-subscribed classes will be split into two qualifying groups by the Chief Timing Officer, based upon their race numbers.

First qualifying session for the class, group 1 will precede group 2, both groups with lowest kart numbers to the front.

Second qualifying session for the class, group 2 will precede group 1, both groups with highest kart numbers to the front.

After qualifying, drivers will be split into 4 groups, A, B, C, or D

Fastest qualifier to group A, 2nd fastest to group B, 3rd fastest to group C, 4th fastest to group D, 5th fastest to group A, 6th fastest to group B, etc until all drivers are allocated a group.

- (b) **Heats:** Each group will race against each other group over three heats.

Fastest qualifier (A group) will race from pole position in the 3 heats.

2nd fastest qualifier (1st in B group) will race from pole position in 2 heats.

3rd fastest qualifier (1st in C group) will race from pole position in 1 heat.

Heats to be run over a distance of 7 kms minimum.

Heat 1a - Group A v's D (grid as per qualifying order)

A's grids 1, 3, 5, 7, etc, D's grids 2, 4, 6, 8, etc

Heat 1b – Group B v's C (grid as per qualifying order)

B's grids 1, 3, 5, 7, etc, C's grids 2, 4, 6, 8, etc

Heat 2a – Group A v's C (grid as per qualifying order)

A's grids 1, 3, 5, 7, etc, C's grids 2, 4, 6, 8, etc

Heat 2b – Group B v's D (grid as per qualifying order)

B's grids 1, 3, 5, 7, etc, D's grids 2, 4, 6, 8, etc

Heat 3a – Group A v's B (grid as per qualifying order)

A's grids 1, 3, 5, 7, etc, B's grids 2, 4, 6, 8, etc

Heat 3b – Group C v's D (grid as per qualifying order)

C's grids 1, 3, 5, 7, etc, D's grids 2, 4, 6, 8, etc

- (c) Point Score System for Heats:

1st- 0 Points

2nd- 2 Points

3rd- 3 Points and so on with one point being added for each place.

- (d) Non-starters and non-finishers to be awarded a finishing position based on the number of laps completed, then the grid position awarded from the start of the heat.

- (e) **Pre-final:** One pre-final. Grid positions for the pre-final will consist of the lowest points scorer from the heats to grid one, second lowest points scorer to grid 2, and so on until the grid is filled to track capacity. In the event of a tie on points, the lower grid position will be awarded to the driver with the faster original timed qualifying.

In the event of any withdrawals from the qualified capacity grid for the pre-final, competitors will be moved up and vacant grids filled with the next available qualifier, up to track capacity.

To be run over a distance of 11km minimum.

- (g) **Final:** One Final: The finishing order from Pre-Final determines grid positions for the final. Winner of pre-final to grid 1, second to grid 2, and so on. Non finishers in the pre-final will be grided at the rear of the field in order of laps completed, then grid position from pre-final. Final to be run over a distance of 16kms minimum.
Finishing order of the final determines the winning positions in each Championship Class.
- (h) All competitors must register a qualifying time and compete in two heats to be eligible for a grid position in the pre-final and final.
- (i) Karts underweight will be excluded from the relevant section of their event (refer to rule 5.03) except during timed qualifying then R16.05(e) applies

CHAPTER 19

CLOSED STATE TITLES AND AUSTRALIAN MASTERS GAMES

CLOSED STATE TITLES

Preamble:

State Closed Titles format, class structure, etc, shall be at the sole discretion of the relevant State Karting Council.

19.01 Title Events: It is recommended that where special regional events are held in each State that these be called "Titles", so that the Regulations that strictly govern Championship Events may be adjusted to local conditions and entries.

19.02 Event Allocation:

A State Closed Title may be conducted annually in each State. The relevant State Karting Council in each State will decide on the allocation of this event to a host club/s.

19.03 Optional:

State Closed Titles may be split into series or divisions, which may be run at separate venues on separate dates.

19.04 Circuit Standard:

The State Closed Titles must only be conducted on circuits of a minimum length of 500 metres and minimum width of 6 meters throughout their entire length. Maximum length of any circuit to be 1.7km.

19.05 Preference for State Closed Titles:

During the conduct of a State Closed Title, no other karting events will be authorised in the same state

19.06 General Standing Regulations and National Competition Rules:

The General Standing Regulations and National Competition Rules as laid down in this manual shall be used for all State Closed Titles.

19.07 Supplementary Regulations and Application for Permit:

Supplementary Regulations for State Closed Titles are to be prepared by the host club in conjunction with the relevant State Karting Council, and must, at least six (6) weeks prior to the date of commencement of the meeting, furnish the State Secretary with the appropriate fee and one (1) complete copy of the proposed Supplementary Regulations, for approval.

Non compliance with this rule will be the imposition of a fine of \$25 per day for each day late. The fine to be the responsibility of the host club.

All appointed officials must be sent a copy of the Supplementary Regulations as soon as approved.

The State Secretaries shall be responsible for the distribution of the approved Supplementary Regulations to their respective affiliated clubs.

19.08 Appointed Officials:

All appointed officials must be recommended by the State Officials Co-ordinator and approved by the relevant State Karting Council. There will be a minimum of Six (6) Stewards.

19.09 Tyre Pooling:

Tyre pooling for State Closed Titles is optional, as per rule 23.11 of the AKA Manual.

19.10 Entry Fee:

The entry fee for State Closed Titles shall be decided by the relevant State Karting Councils and shall include all practice fees and entry to the circuit for the driver and two pit crew.

19.11 Eligible Classes for State Closed Titles:

Eligible classes for State Closed Titles will include those listed under National Championships, (rule 20.10) plus up to an additional six (6) classes as approved by the relevant State Karting Council.

19.12 Entries:

(a) Entries for State Closed Titles shall close a minimum of fourteen (14) days prior to the first day of competition.

Late entries will not be accepted under any circumstances.

(b) **If stipulated in the approved supplementary regulations for the race meeting, the promoting club may reserve the right to accept faxed or email entries before the closing date of entries. These entries MUST be complete with the relevant credit card details for payment. Any extra fee for credit card processing MUST also be stipulated in the approved supplementary regulations for the race meeting**

(c) If less than eight (8) genuine entries are received (with the exception of Tasmania and Northern Territory) to constitute a Class by the listed close of entries then the Class will NOT be contested. All drivers whose entry is not accepted for any Class shall be notified as soon as possible and entry fee will be returned.

In exceptional circumstances the relevant State Karting Council may give approval for lesser entries in a particular class/classes to be run at State Closed Title Events.

The initial request must be made by the promoting club to their State Karting Council Office and such decision may be made by phone hook-up.

(d) **Eligibility is limited to drivers who are holders of a current A, B or C Grade AKA licence issued by the relevant State Office.. The NKC may approve other licence holders outside of the AKA (i.e. International Drivers). D grade or provisional licence holders are not eligible to enter.**

(e) A competitor may only QUALIFY and race one (1) entry per class.

19.13 Practice prior to Qualifying for State Closed Titles:

The Promoters will make available the race circuit for practice for the two (2) days immediately before the event. (Track will be closed to all practice from the Monday prior until commencement of practice). Practice timetable is to be circulated with the Supplementary Regulations and displayed at the circuit.

The Official Practice order of classes must reflect the proposed Qualifying and Race Order.

19.14 Timing and Lap Scoring Recording:

All timed qualifying and lap scoring recording during racing at State Closed Titles to utilise the AKA Competition Management System (CM;S), in conjunction with the AMB TranX 160 transponder system, as per rule 16.05. Manual lap-scoring must also be used as a system back-up for racing.

19.15 Method of Racing for State Closed Titles:

The method of racing for State Closed Titles shall be decided by the relevant State Karting Council from race formats described in chapter 20B

19.16 Results:

The host club shall, within seven (7) days after the end of the meeting, provide to the relevant State Karting Council and to all competitors a dated and signed list entitled "Official Provisional Results".

19.17 Trophies:

- (a) Trophies for State Closed Titles shall be a minimum of \$150 per Class and are the responsibility of the host club.
- (b) STATE CLOSED TITLE WINNERS: Will be allocated BLACK number plates with white numbers bearing their own state number for the period they remain a State Closed Title winners. The plates are to be used only in the class and state they were awarded. (First Place Only.) (Black number plates for State Closed Title winners are to be issued by the Promoting Club and available for presentation with the Trophies.)
- (c) Host Club shall be responsible to forward to the State Secretary, within fourteen (14) days of the event a copy of the financial statement of the monies received for nominations and a detailed list of the exact amount spent.

19.18 Engine and Chassis Sealing (State Closed Titles)

- a) All engines must have provision for sealing in accordance with rule 1.30
- b) AKA bar coded engine seals and chassis tags to be supplied, fitted and recorded by officials of the meeting prior to commencement of competition.
- c) It is the competitors responsibility to check their engine seals and chassis tags for loss or damage prior to leaving the in grid / scales area after each event.
- d) Competitor shall be deemed not to have fulfilled their duty to manage their seals / tags should there be a loss or damage to after leaving the in-grid / scales area after each event, or failure to produce the correct seals / tags when requested.

AUSTRALIAN MASTERS GAMES

19.19 Event Allocation:

The Australian Masters Games are run bi-annually at a pre-determined location across Australia. Karting is recognised as a category for these games. Clubs may apply to host an event through their State Karting Council, who will then liaise with the Australian Masters Games Organisation.

19.20 Circuit Standard:

Karting Events in the Australian Masters Games must only be conducted on circuits of a minimum length of 500 metres and minimum width of 6 meters throughout their entire length. Maximum length of any circuit to be 1.7km.

19.21 Preference for State Closed Titles:

During the conduct of a Karting Event for the Australian Masters Games, no other karting events will be authorised in the same state

19.22 General Standing Regulations and National Competition Rules:

The General Standing Regulations and National Competition Rules as laid down in this manual shall be used for all Karting Events for the Australian Masters Games..

19.23 Supplementary Regulations and Application for Permit:

Supplementary Regulations for Karting Events for the Australian Masters Games are to be prepared by the host club in conjunction with the relevant State Karting Council, and must, at least six (6) weeks prior to the date of commencement of the meeting, furnish the State Secretary with the appropriate fee and one (1) complete copy of the proposed Supplementary Regulations, for approval.

Non compliance with this rule will be the imposition of a fine of \$25 per day for each day late. The fine to be the responsibility of the host club.

All appointed officials must be sent a copy of the Supplementary Regulations as soon as approved.

The State Secretaries shall be responsible for the distribution of the approved Supplementary Regulations to their respective affiliated clubs.

19.24 Appointed Officials:

All appointed officials must be recommended by the State Officials Co-ordinator and approved by the relevant State Karting Council. There will be a minimum of Six (6) Stewards.

19.25 Tyre Pooling:

Tyre pooling for Karting Events for the Australian Masters Games is optional, as per rule 23.11 of the AKA Manual.

19.26 Entry Fee:

The entry fee for Karting Events for the Australian Masters Games shall be decided by the relevant State Karting Councils and shall include all practice fees and entry to the circuit for the driver and two pit crew.

19.27 Eligible Classes for Karting Events for the Australian Masters Games:

Eligible classes and age groups for Karting Events for the Australian Masters Games will include those listed as follows;

| CLASSES | |
|-----------------------------|------------------------|
| 100cc Clubman - Light | 100cc Clubman - Heavy |
| 100cc Clubman - Super Heavy | 100cc National - Light |
| 100cc National – Heavy | Rotax Light |
| Rotax Heavy | Leopard Light |
| Leopard Heavy | |
| AGE CATEGORIES | |
| 30 - 39 | |
| 40 - 49 | |
| 50 - 59 | |
| 60 and Over | |

19.28 Entries:

- (a) Entries for Karting Events for the Australian Masters Games shall close a **minimum of fourteen (14) days** prior to the first day of competition.
Late entries will not be accepted under any circumstances.
- (b) If stipulated in the approved supplementary regulations for the race meeting, the promoting club may reserve the right to accept faxed or email entries before the closing date of entries. These entries **MUST** be complete with the relevant credit card details for payment. Any extra fee for credit card processing **MUST** also be stipulated in the approved supplementary regulations for the race meeting.
- (c) If less than eight (8) genuine entries are received (with the exception of Tasmania and Northern Territory) to constitute a Class by the listed close of entries then the Class will **NOT** be contested. All drivers whose entry is not accepted for any Class shall be notified as soon as possible and entry fee will be returned.
In exceptional circumstances the relevant State Karting Council may give approval for lesser entries in a particular class/classes to be run at Karting Events for the Australian Masters Games.
The initial request must be made by the promoting club to their State Karting Council Office and such decision may be made by phone hook-up.
- (d) Eligibility is limited to drivers who are holders of a current A, B or C Grade AKA licence issued by the relevant State Office.. The NKC may approve other licence holders outside of the AKA (i.e. International Drivers). D grade or provisional licence holders are not eligible to enter.
- (e) A competitor may only **QUALIFY** and race one (1) entry per class.

19.29 Practice prior to Qualifying for Karting Events for the Australian Masters Games:

The Promoters will make available the race circuit for practice for the two (2) days immediately before the event. (Track will be closed to all practice from the Monday prior until commencement of practice). Practice timetable is to be circulated with the Supplementary Regulations and displayed at the circuit.

The Official Practice order of classes must reflect the proposed Qualifying and Race Order.

19.30 Timing and Lap Scoring Recording:

All timed qualifying and lap scoring recording during racing at Karting Events for the Australian Masters Games to utilise the AKA Competition Management System (CM;S), in conjunction with the AMB TranX 160 transponder system, as per rule 16.05. Manual lap-scoring must also be used as a system back-up for racing.

19.31 Method of Racing for Karting Events for the Australian Masters Games:

The method of racing for Karting Events for the Australian Masters Games shall be decided by the relevant State Karting Council, from race formats described in chapter 18 of the AKA Manual.

19.32 Results:

The Promoters shall, within seven (7) days after the end of the Meeting, provide to the AKA and to all competitors a dated and signed list entitled "Official Provisional Results".

19.33 Awards:

- (a) Medals for Karting Events for the Australian Masters Games will be supplied by the Australian Masters Games Organisation

CHAPTER 20

NATIONAL EVENTS

Preamble:

AKA National Events are approved and permitted by the National Karting Council in conjunction with the National Events Administrator, and consist of;

1. The National Sprint Kart Championship,
2. All relevant State Open Sprint Kart Championships,
3. Stand Alone National Sprint Kart Championships for promoter based classes,
4. National Championship series for CIK classes in Australia.

The following regulations shall be strictly adhered to by any person/s (promoter/s), Club/s or State Karting Council given the authority to promote a National Event.

NATIONAL SPRINT KART CHAMPIONSHIPS

20.01 Championship Allocation:

The National Sprint Kart Championships must be conducted annually. State allocation for the event will be on a seven (7) year roster system, as follows;

VIC, W.A., N.T., S.A., N.S.W., TAS, QLD,

The National Sprint Championships will be allocated to the State and host club three (3) years in advance of the competition, after inspection and approval by the National Events Administrator in conjunction with the relevant State Track Inspector. Detailed plans of the circuit, including parc ferme areas and competitors facilities, are to be certified by the relevant State Track Inspector as being correct, and presented to the National Events Administrator.

Prior to a National Championship being conducted on a modified circuit, the Organisers of the event shall be required to satisfactorily conduct at least one race meeting on that circuit.

Additional inspections prior to the event may be necessary. These would be at the cost of the promoting club. If requirements have not been carried or met, the National Karting Council may re-locate the event.

20.02 Circuit Standard:

The National Sprint Kart Championships must only be conducted on circuits of a minimum length of 750 metres and minimum width of 7 meters throughout their entire length. Maximum length of any circuit to be 1.7km.

20.03 Preference for National Sprint Kart Championships:

- a) During the conduct of the National Sprint Kart Championships:
 - (i) No other karting events will be authorised in the same state
 - (ii) In OTHER states only closed or normal sprint race meetings may be held.
 - (iii) No adjoining state is permitted to conduct a major event other than a normal meeting.

20.04 General Standing Regulations and National Competition Rules:

The General Standing Regulations and National Competition Rules as laid down in this manual shall be used for all National Sprint Kart Championships.

20.05 Supplementary Regulations and Application for Permit:

Supplementary Regulations for National Sprint Kart Championships are to be prepared by the **National Events Administrator** in conjunction with the relevant State Karting Council and host club. It shall be the responsibility of the **National Events Administrator** to send approved supplementary regulations to each State Secretary. The State Secretaries shall be responsible for the distribution of the **Supplementary Regulations to their respective affiliated clubs.**

20.06 Appointed Officials:

All appointed officials must be approved by the relevant State Karting Council, except as outlined in the following;

1. There will be a minimum of Eight (8) Stewards for the National Sprint Kart Championships.
2. In consultation with the National Events Administrator and National Coordinators, the Secretariat shall appoint a minimum of ;
 - (a) four (4) Interstate Stewards, each with grade 1 qualifications.
 - (b) two (2) Interstate Technical Officers, and
 - (c) up to four (4) Interstate Scrutineers.
3. Where possible, each Interstate Steward must be from a different State, but the Secretariat reserve the right to appoint a maximum of two (2) Interstate Stewards from the host state of the proceeding year's National Championships.
4. The Chief Steward for the event must be one (1) of the Interstate Stewards and be appointed by the Secretariat from recommendations by the National Events Administrator and National Officials Co-ordinator.
5. The relevant State Karting Council will appoint the remaining Stewards from recommendations made by the State Officials Coordinator.
6. The AKA shall cover travel/accommodation expenses and costs associated with the provision of the interstate AKA appointments.

20.07 Promotional Material:

The AKA retains the "naming rights" sponsorship of the National Sprint Kart Championships. Other sponsors names and logo's may appear on promotional material provided the AKA logo and "National Sprint Kart Championships" wording remains prominent.

20.08 Tyre Pooling:

Tyre pooling for all classes is compulsory at National Sprint Kart Championships, as per rule 23.11 of the AKA Manual.

20.09 Entry Fee:

The proposed entry fee for the National Sprint Kart Championship must be submitted to the NKC at the AGM and National Conference preceding the allocated year. (Submission should include the practice fees and entry to the circuit for the driver and two pit crew)

20.10 Eligible Classes for National Sprint Kart Championships:

| SENIORS | JUNIORS |
|---|------------------------|
| 100cc Clubman - Light | 100cc Clubman |
| 100cc Clubman - Heavy | 100cc National - Light |
| 100cc Clubman - Super Heavy | 100cc National - Heavy |
| 100cc National – Light | |
| 100cc National – Heavy | |
| Leopard Light | |
| Leopard Heavy | |
| NOTE: No additional classes shall be run at National Championships | |

20.11 Entries:

- (a) Entries for National Sprint Kart Championships shall close a **minimum of twenty one (21) days** prior to the first day of competition.

Late entries will not be accepted under any circumstances.

- (b) If stipulated in the approved supplementary regulations for the race meeting, the AKA may reserve the right to accept faxed, email or on-line entries before the closing date of entries. These entries **MUST** be complete with the relevant credit card details for payment. Any extra fee for credit card processing **MUST** also be stipulated in the approved supplementary regulations for the race meeting.
- (c) If less than fourteen (14) genuine entries are received to constitute a Class by the listed close of entries then the Class will **NOT** be contested. All drivers whose entry is not accepted for any Class shall be notified as soon as possible and entry fee will be returned.
- (d) Eligibility is limited to drivers who are holders of a current A or B Grade AKA licence. The NKC may approve other licence holders outside of the AKA (i.e. International Drivers). C grade, D grade or provisional licence holders are not eligible to enter.
- (e) A competitor may only **QUALIFY** and race one (1) entry per class.

20.12 Practice prior to Qualifying for National Championships:

The Promoters will make available the race circuit for a minimum of four (4) days for practice to all nominated drivers. These days for practice are to be within six (6) days of the commencement of the event and listed in the Supplementary Regulations. Practice timetables are to be circulated with the Supplementary Regulations and displayed at the circuit.

Official Practice commences one (1) day prior to Qualifying.

The Official Practice order of classes must reflect the proposed Qualifying and Race Order.

20.13 Timing and Lap Scoring Recording:

All timed qualifying and lap scoring recording during racing at National Sprint Kart Championships to utilise the AKA Competition Management System (CM;S), in conjunction with the AMB TranX 160 transponder system, as per rule 16.05. Manual lap-scoring must also be used as a system back-up for racing.

20.14 Method of Racing for National Sprint Kart Championships:

As per rules 18.01 and 18.04

20.15 Results:

The Promoters shall, within seven (7) days after the end of the Meeting, provide to the AKA a dated and signed list entitled "Official Provisional Results".

20.16 Trophies:

- (a) The AKA is responsible for providing trophies for the AKA National Sprint Kart Championships to a minimum value of \$750 per Class.
(host club to reimburse the AKA on receipt of invoice for cost of trophies)
- (b) NATIONAL SPRINT CHAMPIONS: Will be allocated GREEN number plates with a yellow number 1 for the period they remain a National Champion. The plates are to be used only in the class they were awarded. (First Place Only.) (Green number plates for National Champions are to be issued by the Promoting Club and be available for presentation with the Trophies.)

20.17 Engine and Chassis Sealing (National Championships)

- a) All engines must have provision for sealing in accordance with rule 1.30.9
- b) AKA bar coded engine seals and chassis tags to be supplied, fitted and recorded by officials of the meeting prior to commencement of competition.
- c) It is the competitors responsibility to check their engine seals and chassis tags for loss or damage prior to leaving the in grid / scales area after each event.
- d) Competitor shall be deemed not to have fulfilled their duty to manage their seals / tags should there be a loss or damage to after leaving the in-grid / scales area after each event, or failure to produce the correct seals / tags when requested.

STATE OPEN SPRINT KART CHAMPIONSHIPS

20.18 Championship Allocation:

A State Open Championship must be conducted annually in each State. The relevant State Karting Council in each State will decide on the allocation of this event to a host club/s.

20.19 Optional:

State Open Sprint Kart Championships may be split into series or divisions, which may be run at separate venues on separate dates.

20.20 Circuit Standard:

The State Sprint Kart Championships must only be conducted on circuits of a minimum length of 500 metres and minimum width of 7 meters throughout their entire length. Maximum length of any circuit to be 1.7km.

20.21 Preference for State Open Sprint Kart Championships:

- a) During the conduct of a State Open Sprint Kart Championship:
 - (i) No other karting events will be authorised in the same state
 - (ii) No adjoining state is permitted to conduct a major event other than a normal meeting.

20.22 General Standing Regulations and National Competition Rules:

The General Standing Regulations and National Competition Rules as laid down in this manual shall be used for all State Open Sprint Kart Championships..

20.23 Supplementary Regulations and Application for Permit:

Supplementary Regulations for State Open Sprint Kart Championships are to be prepared by the host club in conjunction with the relevant State Karting Council and National Events Administrator, and must, at least three (3) months prior to the date of commencement of the meeting, furnish the National Events Administrator with the appropriate fee and one (1) complete copy of the proposed Supplementary Regulations, for approval.

Non compliance with this rule will be the imposition of a fine of \$25 per day for each day late, to be invoiced to the State, with redress to the host club.

All appointed officials must be sent a copy of the Supplementary Regulations as soon as approved. The State Secretary shall be responsible for the distribution of the Supplementary Regulations to the other State Secretaries., who will then be responsible to send them on to their respective affiliated clubs.

20.24 Appointed Officials:

All appointed officials must be approved by the relevant State Karting Council, except as outlined in the following;

1. There will be a minimum of Six (6) Stewards. In consultation with the National Events Administrator and National Officials Co-ordinator, the AKA Secretariat shall appoint one (1) Interstate Steward who has grade 1 qualifications who will act as the Chief Steward and one (1) Interstate Technical Officer who shall act as Chief Technical Inspector for the event. The relevant State Karting Council will appoint the remaining Stewards from recommendations made by the State **Officials** Coordinator.
2. The AKA shall cover travel expenses associated with the provision of the Interstate AKA appointments. All other expenses including the evening meal (recommended \$40 limit per night) are the responsibility of the promoting club.

20.25 Tyre Pooling:

Tyre pooling for State Open Sprint Kart Championships is optional (but highly recommended), as per rule 23.11 of the AKA Manual.

20.26 Entry Fee:

The entry fee for State Open Sprint Kart Championships shall be decided by the relevant State Karting Councils and shall include all practice fees and entry to the circuit for the driver and two pit crew.

20.27 Eligible Classes for State Open Sprint Kart Championships:

Eligible classes for State Open Sprint Kart Championships will include those listed under National Championships, (rule 20.08) plus up to an additional six (6) classes as approved by the relevant State Karting Council.

20.28 Entries:

- (a) Entries for State Open Sprint Kart Championships shall close a minimum of fourteen (14) days prior to the first day of competition, **or 21 days prior if tyre pooling is employed.**
- (b) A complete entry list for all classes must be supplied to the National Events Administrator within 72 hours (3 working days) of the close of entries.
Late entries will not be accepted under any circumstances.
- (c) **If stipulated in the approved supplementary regulations for the race meeting, the promoting club may reserve the right to accept faxed, email or on-line entries before the closing date**

of entries. These entries **MUST** be complete with the relevant credit card details for payment. Any extra fee for credit card processing **MUST** also be stipulated in the approved supplementary regulations for the race meeting

(d) If less than eight (8) genuine entries are received (with the exception of Tasmania and Northern Territory) to constitute a Class by the listed close of entries then the Class will NOT be contested. All drivers whose entry is not accepted for any Class shall be notified as soon as possible and entry fee will be returned.

In exceptional circumstances the NKC may give approval for lesser entries in a particular class/ classes to be run at State Open Championship Events.

The initial request must be made by the promoting club through their State Karting Council Office and such decision may be made by phone hook-up.

(e) Eligibility is limited to drivers who are holders of a current A, B or C Grade AKA licence. The NKC may approve other licence holders outside of the AKA (i.e. International Drivers). D grade or provisional licence holders are not eligible to enter.

(f) A competitor may only QUALIFY and race one (1) entry per class.

20.29 Practice prior to Qualifying for State Open Sprint Kart Championships:

The Promoters will make available the race circuit for practice for the two (2) days immediately before the event. (Track will be closed to all practice from the Monday prior until commencement of practice). Practice timetable is to be circulated with the Supplementary Regulations and displayed at the circuit.

Official Practice commences one (1) day prior to Qualifying.

The Official Practice order of classes must reflect the proposed Qualifying and Race Order.

20.30 Timing and Lap Scoring Recording:

All timed qualifying and lap scoring recording during racing at State Open Sprint Kart Championships to utilise the AKA Competition Management System (CM:S), in conjunction with the AMB TranX 160 transponder system, as per rule 16.05. Manual lap-scoring must also be used as a system back-up for racing.

20.31 Method of Racing for State Open Sprint Kart Championships:

The method of racing for State Open Sprint Kart Championships shall be decided by the relevant State Karting Council from race formats described in chapter 18.

20.32 Results:

The Promoters shall, within seven (7) days after the end of the Meeting, provide to the AKA and to all competitors a dated and signed list entitled "Official Provisional Results".

20.33 Trophies:

(a) Trophies for State Open Sprint Kart Championships shall be a minimum of \$300 per Class and are the responsibility of the host club.

(b) STATE OPEN SPRINT CHAMPIONS: Will be allocated BLUE number plates with white numbers bearing their own state number for the period they remain a State Champion. The plates are to be used only in the class they were awarded. (First Place Only.) (Blue number plates for State Open Champions are to be issued by the Promoting Club and available for presentation with the Trophies.)

20.34 Engine and Chassis Sealing (State Open Sprint Kart Championships)

- a) All engines must have provision for sealing in accordance with rule 1.30.9
- b) AKA bar coded engine seals and chassis tags to be supplied, fitted and recorded by officials of the meeting prior to commencement of competition.
- c) It is the competitors responsibility to check their engine seals and chassis tags for loss or damage prior to leaving the in grid / scales area after each event.
- d) Competitor shall be deemed not to have fulfilled their duty to manage their seals / tags should there be a loss or damage to after leaving the in-grid / scales area after each event, or failure to produce the correct seals / tags when requested.

STAND ALONE NATIONAL SPRINT KART CHAMPIONSHIPS

20.35 Championship Allocation:

The following regulations shall be strictly adhered to by any person or Club given the authority to promote a 'Stand Alone' National Championship Event.

- a) The promoter has the right to select the venue.
- b) Allocation of National Championship events to be 1 year.
- c) Additional (support) classes may be run at the discretion of the promoter.

20.36 Circuit Standard:

'Stand Alone' National Sprint Kart Championships must only be conducted on circuits of a minimum length of 750 metres and minimum width of 7 meters throughout their entire length. Maximum length of any circuit to be 1.7km.

20.37 Preference for 'Stand Alone' National Sprint Kart Championships:

- Only closed/normal events will be authorised in the same state, unless further than 150km from the event.
- In OTHER states only closed or normal sprint race meetings may be held.
- No adjoining state is permitted to conduct a major event other than a normal meeting.

20.38 General Standing Regulations and National Competition Rules:

The General Standing Regulations and National Competition Rules as laid down in this manual shall be used for all 'Stand Alone' National Sprint Kart Championships.

20.39 Supplementary Regulations and Application for Permit:

Supplementary Regulations for 'Stand Alone' National Sprint Kart Championships are to be prepared by the promoter in conjunction with the host club and relevant State Karting Council and National Events Administrator, and must, at least three (3) months prior to the date of commencement of the meeting, furnish the National Events Administrator with the appropriate fee and one (1) complete copy of the proposed Supplementary Regulations, for approval.

Non compliance with this rule will be the imposition of a fine of \$25 per day for each day late. The fine to be the responsibility of the Promoter.

All appointed officials must be sent a copy of the Supplementary Regulations as soon as approved.

It shall be the responsibility of the Promoter / relevant State Karting Council to send approved supplementary regulations to each State Secretary at least three months prior to the commencement of the meeting. The State Secretaries shall be responsible for the distribution of the Supplementary Regulations to their respective affiliated clubs.

20.40 Appointed Officials:

All appointed officials must be approved by the relevant State Karting Council, except as outlined in the following;

1. There will be a minimum of Six (6) Stewards. In consultation with the National Events Administrator and National Officials Co-ordinator, the AKA Secretariat shall appoint one (1) Interstate Steward who has grade 1 qualifications who will act as the Chief Steward. The relevant State Karting Council will appoint the remaining Stewards from recommendations made by the State Officials Coordinator.
2. The AKA shall cover travel expenses associated with the provision of the Interstate AKA appointments. All other expenses including the evening meal (recommended \$40 limit per night) are the responsibility of the promoting club.
3. An Interstate Technical Officer who shall act as Chief Technical Inspector may be appointed for the event. All expenses associated with this appointment to be the responsibility of the promoter/ host club.

20.41 Promotional Material:

If requested, sponsors stickers supplied by the race organisers must be placed on all participating karts.

20.42 Tyre Pooling:

Tyre pooling for 'Stand Alone' National Sprint Kart Championships is compulsory, as per rule 23.11 of the AKA Manual.

20.43 Entry Fee:

The entry fee for 'Stand Alone' National Sprint Kart Championships shall be proposed by the promoter in conjunction with the host club and relevant State Karting Council. Final approval must be sought from the NKC via the National Events Administrator. The entry fee shall be GST inclusive, per Driver, per Kart, per Class, and include all fees and entry to the circuit for the driver and two-pit crew. (Tyre pooling / purchasing costs will be extra).

20.44 Eligible Classes for 'Stand Alone' National Sprint Kart Championships:

The only National Championship classes eligible to be run at a 'Stand Alone' National Sprint Kart Championships will be those that have been approved for National Championship status by the NKC. A maximum of four (4) additional support classes may only be run with approval from the National Events Administrator.

20.45 Entries:

- (a) Entries for 'Stand Alone' National Sprint Kart Championships shall close a minimum of twenty one (21) days prior to the first day of competition for National Championship classes and a minimum of fourteen (14) days prior to the first day of competition for any support classes.
- (b) A complete entry list for all classes must be supplied to the National Events Administrator within 72 hours (3 working days) of the close of entries.
Late entries will not be accepted under any circumstances.
- (c) If stipulated in the approved supplementary regulations for the race meeting, the promoter may reserve the right to accept faxed, email or on-line entries before the closing date of entries. These entries MUST be complete with the relevant credit card details for payment. Any extra fee for credit card processing MUST also be stipulated in the approved supplementary regulations for the race meeting

- (d) If less than fourteen (14) genuine entries are received to constitute a Class by the listed close of entries then the Class will NOT be contested. All drivers whose entry is not accepted for any Class shall be notified as soon as possible and entry fee will be returned. In exceptional circumstances the NKC may give approval for lesser entries in a particular class/classes to be run at a 'Stand Alone' National Championship Event. The initial request must be made by the promoting club through their State Office and such decision may be made by phone hook-up.
- (e) Eligibility is limited to drivers who are holders of a current A, or B Grade AKA licence. The NKC may approve other licence holders outside of the AKA (i.e. International Drivers). C grade, D grade or provisional licence holders are not eligible to enter.
- (f) A competitor may only QUALIFY and race one (1) entry per class.

20.46 Private Practice Prior to Qualifying:

The Promoters will make available the race circuit for a minimum of one (1) day for practice to all nominated drivers. The day/s for practice are to be within four (4) days of the commencement of the event and listed in the Supplementary Regulations. Practice timetables are to be circulated with the Supplementary Regulations and displayed at the circuit.

Official Practice commences one (1) day prior to Qualifying.

The Official Practice order of classes must reflect the proposed Qualifying and Race Order.

20.47 Timing and Lap Scoring Recording:

All timed qualifying and lap scoring recording during racing at 'Stand Alone' National Sprint Kart Championships to utilise the AKA Competition Management System (CM;S), in conjunction with the AMB TranX 160 transponder system, as per rule 16.05. Manual lap-scoring must also be used as a system back-up for racing.

20.48 Method of Racing for 'Stand Alone' National Sprint Kart Championships:

The method of racing for 'Stand Alone' National Sprint Kart Championships shall be as described in chapter 18.

20.49 Results:

The Promoters shall, within seven (7) days after the end of the Meeting, provide to the AKA and to all competitors a dated and signed list entitled "Official Provisional Results".

The results will show:

- (a) All entrants in each Class together with their respective total points or finishing order and also fastest qualifying time in each class.

20.50 Trophies:

- (a) The Promoter is responsible for providing trophies for the Stand Alone National Championship classes.
- (b) NATIONAL SPRINT CHAMPIONS: Will be allocated GREEN number plates with a yellow number 1 for the period they remain a National Champion. The plates are to be used only in the class they were awarded. (First Place Only.) (Number plates for National Champions are to be issued by the Promoter and available for presentation with the Trophies.

20.51 Engine and Chassis Sealing (State Open Sprint Kart Championships)

- a) All engines must have provision for sealing in accordance with rule 1.30.9
- b) AKA bar coded engine seals and chassis tags to be supplied, fitted and recorded by officials of the meeting prior to commencement of competition.

- c) It is the competitors responsibility to check their engine seals and chassis tags for loss or damage prior to leaving the in grid / scales area after each event.
- d) Competitor shall be deemed not to have fulfilled their duty to manage their seals / tags should there be a loss or damage to after leaving the in-grid / scales area after each event, or failure to produce the correct seals / tags when requested.

AUSTRALIAN CHAMPIONSHIPS FOR CIK CLASSES

Chapter 43 of the AKA Manual covers specific class regulations and Championship rules for National Championships for CIK Classes.

20.52 Championship Allocation:

The following regulations shall be strictly adhered to by any person or Club given the authority to promote a round of the National Championships for CIK Classes.

- a) The promoter has the right to select the venue.
- b) Allocation of National Championship events will be completed by November of the preceeding year of the Championship.
- c) Additional classes may be run in accordance with the CIK Championship organisers manual.
- d) National Championship for CIK Classes dates shall have precedence over state allocated events and shall be presented to the NKC annually in August.

20.53 Circuit Standard:

National Championships for CIK Classes must only be conducted on circuits of a minimum length of 750 metres and minimum width of 7 meters throughout their entire length. Maximum length of any circuit to be 1.7km.

20.54 Preference for National Championships for CIK Classes:

- a) During the conduct of a round of the National Championships for CIK Classes, (provided 12 months notice is given for specific date)
 - (i) No other major karting events will be authorised in the same state.
 - (ii) In OTHER states, no other major (Championship) events can be authorised.

20.55 General Standing Regulations and National Competition Rules:

The General Standing Regulations and National Competition Rules as laid down in this manual shall be used for all rounds of the National Championships for CIK Classes.

20.56 Supplementary Regulations and Application for Permit:

Supplementary Regulations for each round of the National Championship for CIK classes are to be prepared by the IKC Committee in conjunction with the host club and relevant State Karting Council and National Events Administrator, and must, at least three (3) months prior to the date of commencement of the meeting, furnish the National Events Administrator with the appropriate fee and one (1) complete copy of the proposed Supplementary Regulations, for approval.

Non compliance with this rule will be the imposition of a fine of \$25 per day for each day late. The fine to be the responsibility of the IKC Committee.

All appointed officials must be sent a copy of the Supplementary Regulations as soon as approved. It shall be the responsibility of the IKC Committee / relevant State Karting Council to send approved supplementary regulations to each State Secretary at least three months prior to the commencement of the meeting. The State Secretaries shall be responsible for the distribution of the Supplementary Regulations to their respective affiliated clubs.

20.57 Appointed Officials:

All series Officials to be appointed by the IKC Committee.

1. Series Officials will include;
 - Chief Steward
 - Clerk of Course
 - Chief Scrutineer / Technical Officer
 - Series Co-ordinator
2. There will be a minimum of Four (4) Stewards at each round of the series. The relevant State Karting Council will appoint the remaining Stewards from recommendations made by the State Officials Coordinator.
2. The IKC Committee shall cover travel expenses associated with the provision of the appointed Series Officials. All other expenses including the evening meal (recommended \$40 limit per ight) are the responsibility of the promoting club.

20.58 Promotional Material:

If requested, sponsors stickers supplied by the race organisers must be placed on all participating karts.

20.59 Tyre Pooling:

Tyre pooling for each round of the National Championship for CIK classes is not compulsory, as per article 22 in chapter 43 of the AKA Manual.

20.60 Entry Fee:

The entry fee for each round of the Australian Championships for CIK classes shall be proposed by the IKC Committee in conjunction with the host club and approved by the NKC. The entry fee shall be GST inclusive, per Driver, per Kart, per Class, and include all fees and entry to the circuit for the driver and two-pit crew. (Tyre pooling / purchasing costs will be extra).

20.61 Eligible Classes for the National Championships for CIK Classes:

| SENIORS | JUNIORS |
|---------|---------|
| KF1 | KF3 |
| KZ2 | |

Additional classes may be run at the discretion of the IKC

20.62 Entries:

- (a) Entries for each round of the Australian Championships for CIK classes shall close a minimum of fourteen (14) days prior to the first day of competition for National Championship Classes.
Late entries will not be accepted under any circumstances.
- (b) If stipulated in the approved supplementary regulations for the race meeting, the promoter may reserve the right to accept faxed, email or on-line entries before the closing date of entries. These entries MUST be complete with the relevant credit card details for payment. Any extra fee for credit card processing MUST also be stipulated in the approved supplementary regulations for the race meeting
- (c) For the Series Champion to be crowned the Australian Champion for KZ2 there must have been a minimum of 14 individual entrants across the 4 rounds of the series. In exceptional circumstances the NKC may give approval for lesser entries in a particular class/classes to be run at a each round of the Australian Championships for CIK classes. The initial request must be made by the IKC Committee and such decision may be made by phone hook-up/postal vote.

- (d) Eligibility is limited to drivers who are holders of a current A Grade or A Grade Provisional AKA licence. The NKC may approve other licence holders outside of the AKA (i.e. International Drivers). B grade, C grade, or D grade provisional licence holders are not eligible to enter.
- (e) A competitor may only QUALIFY and race one (1) entry per class.

20.63 Private Practice Prior to Qualifying:

The host club will make available the race circuit for practice to all nominated drivers, as per the approved supp regs for the race meeting. Practice timetables are to be circulated with the Supplementary Regulations and displayed at the circuit.

The Official Practice order of classes must reflect the proposed Qualifying and Race Order.

20.64 Timing and Lap Scoring Recording:

All timed qualifying and lap scoring recording during racing at each round of the Australian Championships for CIK classes to utilise the AKA Competition Management System (CM;S), in conjunction with the AMB TranX 160 transponder system, as per rule 16.05.

Manual lap-scoring must also be used as a system back-up for racing.

20.65 Method of Racing for National Championships for CIK Classes:

The method of racing for each round of the Australian Championships for CIK classes shall be as described in chapter 18 of the AKA Manual, but over distances stipulated in the Supplementary Regulations for the race meeting.

20.66 Results:

The Promoters shall, within seven (7) days after the end of the Meeting, provide to the AKA and to all competitors a dated and signed list entitled "Official Provisional Results".

The results will show:

- (a) All entrants in each Class together with their respective total points or finishing order and also fastest qualifying time in each class.

20.67 Trophies:

- (a) The IKC Committee is responsible for providing trophies for all CIK classes contested at each round of the Australian Championships for CIK classes
- (b) NATIONAL SPRINT CHAMPIONS: Will be allocated GREEN number plates with a yellow number 1 for the period they remain a National Champion. The plates are to be used only in the class they were awarded. (First Place Only.) (Number plates for National Champions are to be issued by the Promoter and available for presentation with the Trophies.

20.68 Engine and Chassis Sealing (National Championships for CIK Classes)

- a) All engines must have provision for sealing in accordance with rule 1.30.9
- b) AKA bar coded engine seals and chassis tags to be supplied, fitted and recorded by officials of the meeting prior to commencement of competition.
- c) It is the competitors responsibility to check their engine seals and chassis tags for loss or damage prior to leaving the in grid / scales area after each event.
- d) Competitor shall be deemed not to have fulfilled their duty to manage their seals / tags should there be a loss or damage to after leaving the in-grid / scales area after each event, or failure to produce the correct seals / tags when requested.

CHAPTER 21

AKA EQUIPMENT & HOMOLOGATIONS PROCEDURES

Homologations and Registrations of products for use in AKA require formal applications. Please contact the National Office for the appropriate documents and the instructions and requirement for such applications.

Preamble:

A key factor of homologation of a component or engine is that it must be in the best interests of AKA Karting and, as such, be supported and recognized by the AKA that it is complementary to current and future directions of karting. Homologation **does not** imply or guarantee use in a class or classes or for practice / private practice.

Application for use in a class or classes or for practice / private practice must be applied for after Homologation approvals.

21.01 Homologation Procedure.

The homologation procedure can be divided into five distinct phases:

Phase 1: Initial Application and homologation application Fee.

This phase requires the applicant to formally submit the following documentation to the AKA National Office with the appropriate Homologation Application Fee:

- Homologation application form that is to be correctly filled out in all relevant sections
- Photos of the component or engine
- Any other relevant technical or support information.
- In the case of an engine, a proposed set of technical rules and gauges or electronic checking devices that would form the basis of a class chapter.
- A covering letter that describes the component or engine and the applicant's perspective as to the benefits and areas of application within the AKA class structures.

Homologation Application Fee.

A Homologation Application Fee must be paid with each Homologation Application. This fee is not refundable if the application is withdrawn, nor, if the application is not approved by the NKC.

The following fees apply:

a) **Evolution Component:** (Refer to rule 21.06.9)

The fee is **\$500.00 plus G.S.T.** per application for an Evolution Component.

One (1) Evolution Component change per calendar year is allowed.

The fee for any further evolution component applications **doubles** for each application within that particular calendar year.

b) **Aftermarket Component:** (Refer to rule 21.05.10)

The fee is **\$500.00 plus G.S.T.** per application for an Aftermarket Component.

One (1) Aftermarket Component change per calendar year is allowed.

The fee for any further evolution component applications of an aftermarket component **doubles** for each application within that particular calendar year.

c) **Engine:** (Refer to rule 21.06.4)

The fee is **\$1,500.00 plus G.S.T.** per application for an Engine.

All applications are reviewed by the NKC and any other AKA committee groups as deemed necessary to fully evaluate the suitability of the application. The Applicant will be informed of the acceptance of the initial application within a period of 60 (sixty) days.

Should the AKA not respond within a 60 (sixty) day period, the application fee will be refunded.

In this circumstance, the applicant is permitted to re-submit the application.

Phase 2: Technical Examination.

After successful initial application, the applicant must then submit two (2) samples of the engine or component and two (2) samples of any appropriate gauges to the AKA National Office. These will then be passed on to the National Technical Committee examination against the specifications supplied as part of the initial application.

The Applicant will be informed of the technical outcome of the examination within a period of 60 (sixty) days. Should the AKA not respond within a 60 (sixty) day period, the application fee will be refunded and the applicant is permitted to re-submit the application.

The AKA reserves the right to full possession of any engines or components submitted with an application. Should the AKA decide to dispose of such engines or components, the first right of refusal of sale will go to the applicant (if known), otherwise the engines or components will be destroyed and scrapped if not sold.

Phase 3. Final Homologation.

After examination and written confirmation of this by the National Technical Coordinator, the AKA will review the overall application. In the majority of cases, the homologation application will be approved after it has passed through the Initial Application and Technical Examination phases.

Final Homologation does not imply or guarantee use in a class or classes or for practice / private practice. Application for use in a class or classes or for practice / private practice must be applied for after Final Homologation approvals.

Phase 4: Application for use in a class.

After final homologation approval has been granted by the AKA, application must be made to the NKC for the engine or component to be included for use into a class or classes.

A fee of \$500.00 per class will apply for a **Component Application for use** into an existing class.

A fee of \$500.00 per class will apply for an **Engine Application for use** into an existing class.

A fee of \$3,500.00 per class will apply for an **Engine Application for use** for a "Stand Alone" or "Experimental" class.

A fee of \$5,500.00 will apply for an application to have a promoter based class. Should such a class be approved, a contract between the AKA and the Promoter shall be entered into for a time to be determined. The contract shall contain a further schedule of annual fees, royalties, etc, and/or further conditions.

Should the homologated engine or component be accepted for use within a rulebook period, an appropriate addendum will be released confirming the allowable use of such engine or component.

Phase 5: Re-homologation.

After a period of 9 (nine) years from date of homologation acceptance or start date of competition use (as per 21.06.2) and whichever is later, the homologation period is deemed to terminate. The initial applicant will be advised by the AKA 3 (three) months prior to this. Should the applicant wish to initiate another homologation period, it will require the Applicant to reapply and to formally submit the following to the AKA National Office with the appropriate Homologation Application Fee. (Note that any submission documentation and hardware must include any evolution changes incurred in the preceding 9 (nine) year homologation period):

- Homologation application form that is to be correctly filled out in all relevant sections
- Photos of the component or engine
- Any other relevant technical or support information

- In the case of an engine, a proposed set of revised technical rules and gauges or electronic checking devices that would form the basis of a renewed class chapter.
- A covering letter that describes the component or engine and the applicant's perspective as to the benefits and areas of application within the AKA class structures
- Application fee. This application fee is not refundable and is \$500.00 for a component and \$1,500.00 for an engine for a further 9 (nine) year period.
- The engine or component and any appropriate gauge or electronic checking devices.

21.02 Compliance Costs.

Any and all costs for software and / or gauging for compliance checking of engines or components will be at the cost of the company or person applying for, or has, homologation. This shall include but not limited to one (1) set of equipment per state and territory plus one (1) set to be retained at the National Office. This shall also apply to all contracted classes.

21.03 Further comments on Homologation.

- Homologation **does not** imply or guarantee use in a class or classes. Application for use in a class or classes must be applied for after Homologation approvals.
- Any engine or component that is specifically initiated by the AKA may be subject to homologation fees or period. This implies, however, that engines or components that are tendered on ARE subject to appropriate homologation fees, and a 9 (nine) year homologation period.
- ALL engines and components may be subject to homologation fees and periods. The AKA commits to a moratorium on all AKA initiated engines or components for a period of 3 (three) years, other than reasons of "force majeure" and safety.
- The Applicant of a homologated engine or component is free to submit suggested rule changes to the AKA for review at any time. Should an addendum or inclusion into the following year's rulebook be required to incorporate such a rule change, a fee of **\$500.00** will be applied, although this may be waived at the AKA's discretion only with the Technical Committee's recommendation.

Note: This is not to be confused with an Evolution Component change.

- Should an Applicant, Manufacturer or AKA Recognized Distributor not make timely payment of an annual fee, an AKA Contract fee or a re-homologation fee, the AKA from that point in time reserves the right to take complete control of the application of any such relevant engine or component in any class. (refer 21.06.2)
- The AKA recognizes that homologation of engines and components is a necessary and important part of karting, but must be undertaken with the best interests of current and future directions of karting.

21.04 TYRES: The AKA adopts a contracted tyre tender policy for the allocation of tyres to domestic restricted classes. This tender process operates on a 3 years evolution for both slick and rain tyres. A testing protocol for the contracted tyre tender is available from the National Office. A further protocol for testing tyres for consideration outside of contracted tender periods also exists. Such applications can be made through the National office and with the assistance of the National Technical Coordinator – Fees are applicable for all such testing applications, and are set at \$300.00 per application. All tyre contracts are subject to AKA royalties – classes not controlled by a tender contract will also be subject to tyre royalties Tyres for consideration for use outside the tyre tender process are subject to the policy applications and fees – these details are available from the National office.

21.05 CHASSIS: HOMOLOGATION OF CHASSIS

1. Homologation of Chassis with AKA Application forms and full details are available from the AKA National Office
2. Homologation of Chassis with CIK Refer to the FIA/CIK Manual. The relevant paperwork is available from AKA National Office.
3. Homologation of non CIK Homologated Australian Made Chassis To compete in KZ2- KF3 and KZ2 application paperwork, must be lodged together with the appropriate fees at the AKA National Office. Application forms and full details are available from the AKA National Office.

21.06 The following definitions are used in this chapter:

1. **"Homologation"**.
An engine or component that has been approved in accordance with this chapter 21, can be used on AKA tracks under the conditions as finally approved by the AKA within the homologation approval documentation. The previously used term of Registration is no longer used and Homologation is the only approved term.
2. **"Homologation period"**.
Any item that is homologated has a homologated period of 9 years. The commencement period of a homologation will be indicated in the homologation approval by the AKA. After that time the component must be re-homologated for a further period. Failure to pay the fee within the due period could result in the component or engine withdrawn from use and a further fee will be applicable for its reinstatement.
3. **"Applicant."**
This might be an individual, a Manufacturer or Recognized Distributor, as appropriate.
4. **"Engine"**.
All engines that use AKA tracks must be homologated. A homologated engine is a complete stand-alone power unit that includes carburetor and ignition system and in some cases also includes cooling system, starting system, clutch system, induction system and exhaust system. The only engines that will be considered from 1st January, 2009 for future homologation must have a CNC machined cylinder liner of un-plated magnetic material with a tolerance of +/- 0.05 from the top deck of the liner to the top of the exhaust and transfer ports. No other type of cylinder will be eligible for homologation. The exception to this might be engines submitted in the Open Class, ICC, etc.
5. **"Experimental Class or Class Engine"**.
For certain reasons, the AKA may create an Experimental Class to determine the acceptance of such a class in the future, or as part of a future class structure, and also to allow an engine manufacturer to "fine tune" the engine to suit the needs of that class for the requirements of the AKA.
 - This experimental class will have a homologation period of 3 years. –
 - The fees of homologation of an engine in an experimental class is the same as any other Engine, but is allowed up to 3 (three) free evolution changes during the (3) year homologation period.
 - The application for an Experimental Class must follow the same procedure as any engine homologation application, and is subject to AKA/NKC approval.
 - An Experimental Class can be continued on a yearly basis, the same fees are applicable for each year.
 - The AKA shall determine if an engine is Experimental.

- All new engines must undergo an Experimental Class or Class Engine period, with a minimum of (3) calendar years.
 - An Experimental Class Engine may run within another existing class, but only with formal approval from the AKA.
6. **“CIK Homologated Engine.”** CIK Homologated engines are those that have a current FIA/CIK Homologation number and have current CIK homologation technical documentation, Such homologated engines are eligible for use in AKA CIK classes, Formula 100, and Open Performance AKA classes. These engines do not require AKA Homologation but will require to be sanctioned and registered with the AKA via an application for use in the domestic categories of F100 and Open Performance.
 7. **“AKA Contract.”** The AKA may, in the interests of a particular class, accept a contract with an Applicant that confirms that the only engine used in that particular class is that which is the subject of the contract. This is in addition to other costs with respect to homologation, but does not include any other annual fees. Note also that the AKA has the right to make any other changes in the relevant class chapter, other than allowing another type of engine to be used in that class.
 8. **“Component.”** Whilst most components requiring homologation approval are engine related, there are other performance and power transmission related components that require homologation. A component might be a single part, or an assembly of parts. Note that such an assembly can be referred to as a part, but an engine is not referred to as a part. Components can be broadly classified into two distinct types:
 9. **“Evolution Components.”** For reasons of quality improvement, design improvement, safety, production costs and manufacturing considerations, a component that is so changed is regarded as an Evolution Component, and must be able to be interchangeably used with the previously used component. The manufacturer or AKA recognized distributor can only make the application for an Evolution Component.
 10. **“Aftermarket Component.”** This is a component that can replace an Original Equipment Manufacture (OEM) component in any AKA homologated engine or component, but is NOT classed as a Non-Tech component (as described in R25.21, or as specifically outlined in a class chapter). Acceptance of an aftermarket component is based on reasons of cost benefits to the karter, availability, safety and any known possible negative issues of an OEM component. There is no restriction to aftermarket components being accepted into classes where an AKA Contract is in place.

CHAPTER 22

FUEL / FUEL TESTING

22.01 Fuel Testing:

1. The digatron DT15 or DT47 series fuel testing kit will be the official preliminary fuel testing method to be used by the AKA and the State Karting Councils.
Prior to any test conducted, competitors must acknowledge if they are using PULP and Testers must ensure the digatron is not contaminated from any test on ELF fuels. This applied vice versa.

2a. Method (for competitors using PULP)

- a) Rinse digatron in Fresh Premium Unleaded Fuel before use.
- b) Set Digatron Meter to .000 in a sample of fresh Premium Unleaded Petrol.
- c) Conduct test on competitor's fuel either in the fuel tank or on a sample removed from the fuel tank.
- d) Should the first test fail, a second test to be conducted on a sample removed from the competitor's fuel tank. The temperature of the zero sample and the competitor's sample to be adjusted so that the temperature difference between the two does not exceed 3 degree Celsius.
- e) If the results from the second test from the Digatron DT14 AND OR DT47 Series Meter be less than zero or greater than +40 units then it will require a sample to be taken for laboratory analysis.

2b. Method (for competitors using ELF BFK 07)

- a) Set Digatron Meter to .000 in a sample of fresh ELF BFK 07 fuel.
 - b) Conduct test on competitor's fuel either in the fuel tank or on a sample removed from the fuel tank.
 - c) Should the first test fail, a second test to be conducted on a sample removed from the competitor's fuel tank. The temperature of the zero sample and the competitor's sample to be adjusted so that the temperature difference between the two does not exceed 3 degree Celsius.
 - d) If the results from the second test from the Digatron DT15 AND OR DT47 Series Meter be less than zero or greater than +40 units then it will require a sample to be taken for laboratory analysis.
3. The AKA/SKC retains the option to use any other fuel testing method.
 4. In the event of an Appeal against the above Fuel Testing procedure, fuel samples may be tested by an independent laboratory, with the total cost to the Appellant.

22.02 Random Samples

Randomly selected competitor(s) may have a sample of their fuel or lubricant taken and sealed for later laboratory analysis. If the fuel is found not to comply a complaint shall be made to the State Tribunal Registrar by the Fuel Tester under Rule 7.06 and the competitor(s) shall be subsequently charged with an offence under Rule 5.01(q). The cost of such testing shall be borne by the promoting club or otherwise agreed.

22.03 Fuel: For All Classes

1. Safety:

- a) All participants in motor sport are reminded that fuel, oils, lubricants, and coolants are highly specialised substances.
- b) Participants must be aware that these agents may contain substances that are extremely dangerous to one's health if misused, inhaled or allowed to contact human skin.
- c) Some of the contents of these fuels, oils, and lubricants are suspected of having the potential to cause cancer in rare instances.
- d) The use of petrol as a general cleaning and washing agent is a common misuse of a potentially dangerous substance.

2. Purpose of this article:

- a) Is to ensure that the fuel used in Kart Racing is consistent with Premium Unleaded Petrol, as this term is generally understood.
- b) Petrol within the meaning of these regulations is one of the following:
 - i) Petrol and/or fuel of a kind recognised by the AKA as being on general and genuine sale to the public in Australia.
 - ii) Petrol and/or fuel that has been approved by the AKA.

3. Permitted Fuels:

- a) The only petrol's and/or fuels permitted are:
 - i) Premium Unleaded Petrol (PULP) having properties and characteristics as required by Federal and/or State Government Regulations for PULP.
 - ii) Fuel that has been approved by the AKA (which also will conform to government requirements).
- b) Any petrol that appears to have been formulated in order to subvert the purpose of this regulation will be deemed to be outside it.
- c) In addition, the fuel must contain no substance, which is capable of exothermic reaction in the absence of external oxygen.
- d) Test methods for permitted fuels will be as recommended to the AKA from time to time by the National Fuel Tester.

4. Additives & Engine Lubricants:

- a) Only ambient air may be mixed with the fuel as an oxidant.
- b) Only commercially available motor oil that does not contain a performance-enhancing additive may be used. If requested a competitor must advise the relevant officials which brand/type and ratio of oil he/she is using.
- c) No substance other than oil as described in this rule may be added to petrol used in competition.

5. Fuel Testing & Sampling:

- a) The Digatron DT15 OR DT47 Series Fuel Testing Kits will be used to test fuel. Refer to Rule 22.01 for testing procedure. The AKA may also use any other recognised testing procedure to test the petrol and/or oil used by a competitor.
- b) All samples will be taken in accordance with a detailed procedure for fuel testers that is issued and updated from time to time by the National Fuel Tester.

6. **Illegal Fuel Penalty:**

The non-compliance to these fuel Rules is punishable by a Penalty of up to five (5) years suspension.

7. **Control Fuel:**

Promoters of major events may state the details and availability of a control fuel. These details must be on approved Supplementary Regulations for the event and will automatically constitute the designated fuel for that meeting. A control fuel cannot be a fuel, which is not an approved fuel. The control fuel at the National Championships for and Formula 100 may be ELF Euro 102.

8. **Fuel Approval**

Before any fuel may be accepted as an approved fuel, it must have all government approvals in writing. AKA may conduct an analysis before acceptance. A sample must be submitted to the AKA for analysis and approval.

The AKA reserves the right to charge all costs associated with the fuel approval procedure back the applicant. The decision of the AKA as whether a fuel meets AKA approval is final, and no appeal may be entered. No fuel may be used under this rule in any AKA event without prior approval.

9. **Approved Fuels:**

a) For General Use – PULP produced by major refineries, Elf BFK 07

b) Control Fuels

Note: Elf EURO102 is specifically formulated for CIK performance engines and may be approved for general karting categories and/or events by the AKA.

c) List of approved fuels.

1. For General use PULP produced by major refineries **and** including ELF BFK 07

2. ELF Euro 102 – is specifically formulated for CIK performance engines and may be approved for general karting categories and/or events by the AKA.

22.04 **Fuel Container:**

Shall be securely mounted in front of driver, made of a leak proof material and mounted so that it does not project in a manner likely to cause a hazard or a spillage. All fuel containers to be fitted with a male connector or accept the flexible fuel line. Flame retardant materials are recommended. The fitting of overflow bottle/s is compulsory. (150ml minimum total.) All flexible fuel line connections are to be wired or clipped to the satisfaction of the Scrutineer. Fuel taps are optional. Karts fitted with float carburettors must have a catch tank included in the carburettor vent system to catch surplus fuel in the event of the carburettor flooding.

CHAPTER 23

TYRES

23.01 General:

Tyres shall be new or in good condition with no apparent flaws.

No modifications to tyres are permissible.

Outside diameter: 310mm max – 220mm min.

Radial tyres are NOT permissible.

Tyre pressure bleed off valves are NOT permitted.

23.02 Bead Retention:

1. This sub-rule applies to all dry tyres used in the following classes:
Open Performance and all Unrestricted 125 classes.
2. It does not apply to Dirt Track racing or wet weather tyres.
3. Rims to have a form of full positive bead retention on the outer rim.



Method of Tyre Bead Retention

3 off M4 minimum screws threaded through the rim behind the tyre bead at approximately 120 degrees.

Screws must protrude inside the rim by at least 3mm.

23.03 Tyre Treatment:

1. It is not permissible to tamper with any tyre, to alter its hardness, construction or composition with any method or agent including the use of an electric heat gun.
2. Checking of Tyres:
 - (a) An approved measuring instrument may be used for checking tyres for illegal agents/solvents and for shore hardness.
 - (b) A photo ionisation detector (PID) and durometer are approved measuring instruments for checking tyres for illegal agents/solvents and shore hardness.
 - (c) A photo ionisation detector (PID) with a calibration certificate for isobutylene at 100ppm, issued in the preceeding 12 months may be used for testing for chemical treatment of tyres.
 - (d) A reading greater than 3ppm on a PID (as described in rule (c) above), with the sampling probe within 5mm of any part of the tyre or tread, where the reading is 50% greater than the average readings found on tyres from other competitors in the race will be deemed evidence of chemical treatment.
 - (e) A reading greater than 250ppm on a PID (as described in rule (c) above) when sampling the air expelled from the tyre via the tyre valve, will be deemed evidence of chemical treatment.
 - (f) If chemical treatment of tyres is established, as above, competitor will be excluded from the race meeting and their licence fully suspended for 12 months. This decision and penalty is non-appealable.

23.04 Preheating of Tyres:

Preheating of tyres is not permissible before leaving the out-grid.

23.05 Weaving to Warm Tyres:

Refer Rule 16.09 (ii).

23.06 Number of Tyres Permitted:

Refer Rule 1.32(2) and respective Class Rules

23.07 Combination of Tyres:

The mixing of wet and dry category tyres, on the kart at any one moment, is not permitted.
This rule is not applicable to speedway racing.

23.08 AKA Contracted Tyre Prices

| TYRE | RETAIL |
|----------------|--|
| Dunlop SL1A | \$242.00 per set \$227.00 Midget/ Rookies 4 X 450 |
| Dunlop SL6 | \$295.00 per set |
| MG FZ Yellow | \$255.00 per set |
| MG AZ-Red | \$235.00 per set |
| Dunlop KT6SLW1 | \$289.00 per set \$267.30 per set from 1st may 2011 |

23.09 APPROVED TYRES:

1. AKA approved dry tyres – The following tyres are accepted by the NKC for selection in AKA classes where tyre contracts/restrictions are **NOT** specifically designated for competition.

| | |
|-------------|-------------------------------------|
| Bridgestone | YGK and YJC and YGL and YDS |
| Dunlop | SL1A and SL6 and SL5 |
| Maxxis | HG3 |
| MG | AZ – (Red) and FZ – (Yellow) and HZ |
| MOJO | D2 D3 |
| Yokohama | MF – GP1 and MS – YO1 |

2. AKA approved wet tyres – The following are accepted by the NKC for selection in AKA classes where tyre contracts / restrictions are NOT specifically designated for competition.

| | |
|-------------|---------|
| Bridgestone | YGR |
| Dunlop | KT6SLW1 |
| MG | WZ |
| MOJO | MOJO W2 |

3. CIK homologated group 2 wet weather tyres as designated by IKC 2011
4. CIK homologated group 2 slick tyres – as designated by IKC 2011

23.10 The following AKA classes are restricted to:

| CHAPTER | CLASS | DRY TYRE | WET TYRE |
|---------|-----------------|---------------------------|---------------------------|
| 27 | Midget | Dunlop SL1A | Dunlop KT6SLW1 |
| 28 | Rookie | Dunlop SL1A | Dunlop KT6SLW1 |
| 29 | Jnr Nat | Dunlop SL1A | Dunlop KT6SLW1 |
| 30 | Jnr Clubman | MG AZ Red | Dunlop KT6SLW1 |
| 33 | Snr Nat | Dunlop SL1A | Dunlop KT6SLW1 |
| 34 | Clubman | MG AZ Red | Dunlop KT6SLW1 |
| 41 | Formula 100 | MG FZ Yellow | Any CIK Group 2 wet |
| 39 | Leopard 125 | MG FZ Yellow | MG WZ |
| 40 | Tag 125 | MG AZ Red | MG WZ |
| 35 | Yamaha TAG100 | Dunlop SL1A | Dunlop KT6SLW1 |
| 38 | Form Rotax | Mojo D2 | Mojo W2 |
| 42 | Open Perf Class | As per Class spec | As per Class Spec |
| 36 | Sportsman | AKA—dry (State Rule) | Dunlop KT6SLW1 |
| 43 | KF1 / KZ2 / KF3 | as designated by IKC 2011 | as designated by IKC 2011 |
| 37 | Restricted 125 | MG AZ Red | Dunlop KT6SLW1 |
| 31 | Formula JMA | Mojo D2 | Mojo W2 |

1. **Classes restricted to: Bridgestone, Vega SL4, MG AZ Red and FZ Yellow and Maxxis HG3, Dunlop SL6 or Mojo D2** may only use 4.5/10 - 5 front and 7.1/11-5 rear.
2. **Classes restricted to: Dunlop SL1A** may only use 4.5/10 - 5 front and 7.1/11 - 5 rear except Midgets and Rookies where they may option to use Size: 4.5/10 - 5 rear.
3. **Classes restricted to Dunlop KT6SLW1** may only use 4.0/10 - 5 front and 6.5/11 - 5 rear except Midgets and Rookies where they may option to use size 4.0/10 - 5 rear.

23.11 Tyre Pooling

Tyre Pooling for restricted / designated dry weather tyres will be compulsory at the Australian National Championships. Tyre pooling at this event must comply with the following regulations. Tyre pooling optional for State Championships.

1. The entry fee for all restricted tyre classes will incorporate at the cost (as per tyre contracted price) of one (1) set of tyres per class per driver only.
2. The promoting club at the designated circuit will provide one (1) set of tyres per driver per class at least one day prior to time trials.
3. Tyres supplied by the promoting club will be as per the manual and will be of the same batch number within each class. (eg. All clubman light entrants must be issued with the same batch number etc.)
4. All tyres supplied by the promoting club will be scanned with the AKA Barcode Scanning System or marked with the race number and class they are to be used in prior to the start of competition for the race meeting.

It is the driver's responsibility to ensure that at least one barcode per tyre remains scannable at any time for the duration of the race meeting. Any damaged or unreadable tyre barcodes must be reported to the scrutineers prior to leaving the in-grid / impound area. These tyres will be stamped internally then externally marked with class and racing number and dually recorded before leaving the in-grid / impound area.

5. The promoting club may issue only one set of tyres per driver per class.
6. Damaged or worn out tyres (by way of force majeure) must be reported to and be inspected by the Chief Scrutineer prior to the kart leaving the grid/impound area, replacement(s) will be at the competitors cost.

Drivers receiving a new replacement(s) will be required to start at the rear of the grid in their next competition, the only exceptions to this is a tyre with a manufacturing defect (as approved by the tyre representative and/or the Chief Scrutineer).

7. In case of any "force majeure", the promoting club will order in addition to the one set per driver per class, 5% (five percent) extra quantity of each type of tyre.
8. The promoting club will obtain (and comply with) via their state body a copy of the conditions governing the transaction between the promoting club and the tyre supplier.
9. An unused tyre having a circumference variation of more than 10mm may be exchanged. The circumference is to be measured at the centreline of the tread area and tyres are to be mounted and inflated to a similar pressure. In consultation with the tyre supplier.

AKA Tyre Testing and Sampling Procedure

When checking tyres for tyre treatment using the Photo Ionisation Detector (PID) at the race meeting if the PID shows a reading on a tyre allow the equipment to zero and check another site on that tyre by leaving the snorkel just touching the tread surface for 2 seconds.

If you get a reading on the second site of the same tyre check all the other tyres on the Kart using the same procedure. If all the other tyres do not show a reading, allow to race but check again through the meeting.

When 2 tyres or all 4 show a similar reading for each tyre on the PID allow the kart to race the heat and impound on completion of the heat even if the kart has a DNF.

When you get a reading on 2 or more tyres a rubber sample has to be sent away to the Gas Chromatograph for the final verification of a substance or compound being introduced into the rubber of the tyre. The rubber sample sent would then be compared against the standard tyre sample with a graph overlay that will clearly indicate the presence of an introduced substance or compound in the tyre sample.

This Gas Chromatograph testing procedure is the same as the fuel test so it is conclusive. If the sample rubber does not compare with the standard sample this then is the final verification that the tyres have had a substance or compound introduced to change the properties of the rubber in the tyre.

The rubber samples (2) should be taken from the same site on one tyre that showed the reading on the PID eg if the two front tyres show a reading either one will do, if it is only the back two tyres that show the reading take the samples from the one away from the motor, if it is one front and one rear on one side take the samples from the one that is away from the motor. When all four tyres have a similar reading take the samples from the rear tyre on the brake side.

Using a new or clean NT cutter, equivalent or scalpel that has been cleaned with a clean lint free cloth or tissue cut a sliver of rubber about 10 mm long 5 mm wide and 0.5 deep from the tread surface taking care not to cut deep into the tyre.

After cutting the sliver from the tread surface of the tyre cut the rubber sample into to equal parts. Being very careful not to cut into the tyre then using tweezers or knife tip put the samples into the clean glass vial with each sample having their own new glass vial and screw on the lid. Then seal in the plastic bottle using the same bottles that are supplied for fuel samples. These are available for purchase from National Office via State.

Once the sample bottles have been sealed using the sample method and paper work, as is used in fuel samples, ask the competitor to choose one sample and inform him that the other sample will be sent to the Gas Chromatograph for final verification of the presence of a substance or compound in the tyre rubber.

When the report is received at State Office from the Gas Chromatograph testing and it is positive this is then sent to the State Tribunal Register to handle.

CHAPTER 24

NOISE CONTROL

- 24.1**
1. The AKA is of the opinion that control of noise is emerging as a major issue for motor sport and that increased Government controls may be imposed on those motor sport organisations and individuals that exceed the stated levels. The potential for noise injuries to our Officials, Competitors and their crews must also be addressed and minimised. Karting as a stand alone Sport can not allow an individual or club to selfishly satisfy themselves to the detriment of the Sport now or in the future. Competitors and those involved with Kart preparation are required to closely check all fittings and fastenings associated with the control of noise on their Kart and to maintain a vigilant and preventative stance to noise control.
 2. The permitted noise emission level from a kart must not exceed 100 dBA when measured at a point 4 metres away with AKA vertical methods.

24.2 Permitted Noise Level:

At all events, tracks and venues licensed or approved by the AKA the permitted noise levels are

1. At normal tracks the permitted noise levels, must not exceed **100DBA** when measured at a point 4 metres above the centre of the track (refer penalties rule 24.7).
2. Clubs may apply to the National Karting Council for an exemption to the AKA noise regulations. Supplementary Regulations may stipulate a lesser Noise Level for the complete meeting or for any part or component as designated.

24.3 Noise Measuring:

1. At all race meetings an official must be nominated Judge of Fact (Noise Level) and his/her name included in the regulations for the meeting.
2. The Stewards must ensure that the Organisers have the necessary noise measuring devices in place and that they are in operation throughout the entirety of the race meeting.
3. In order to assist competitors after each practice and qualifying session, drivers of karts which record sound levels of 98 dBA to 100 dBA (using AKA vertical method) should be advised by the officials.
4. Results of any Noise Measuring testing at a meeting, duly signed by the responsible Official, are to be given only to the Clerk of Course or Stewards who will then take any necessary action before clearing them for general distribution.

24.4 Noise Testing Equipment:

1. The Sound Level Meter tested and approved for the stipulated noise level tests is – Make PCWI, Model 8921 and is available complete with microphone and cables through the AKA. Any alternate or secondary unit must conform to the minimum requirements of Australian Standards AS1259 part 1982 for Type 2 Meters.
2. Sound Level Measurements are to be made in accordance with the procedures in Australian Standard AS2659.1 – 1988 "Guide to the Use of Sound Measuring Equipment Part 1 Portable Sound Level Meters" using 'F' time weighting characteristic, normal incidence microphone and 'A' weighting.

3. The test positions are to be set by the State Track Inspector and should be sited;
 - (a) to measure karts when they are under maximum acceleration and are operating at a minimum of 75% of their rev range
 - (b) to ensure that the maximum noise level emitted by a kart is measured
 - (c) to ensure minimum reflection from buildings / structures.
4. The microphone is to be located a maximum of 10 metres from the outside edge of the track, 1.2 metres from the ground and facing towards the track. The microphone must be free from "solid objects" that are able to ricochet sound.
5. It is recommended that all sound meters utilise remote microphones. This is to permit the sound meter and the operator to be located away from the microphone at a safer distance from the track where they can be behind a safety barrier without affecting the noise level at the microphone.

24.5 Supplementary Testing:

The Stewards or Clerk of Course may direct a competitor to submit his/her Kart to a noise test at any time during a competition or race meeting. This is to enable the Officials to test selected Karts at the end of a competition, race, heat, time trial or qualifying session should it prove difficult to assess their levels during that activity. If such a test is to be done, the Kart should be impounded and tested before any work can be carried out to the Kart. Competitors must comply with any reasonable request from the Officials.

24.6 Noise Offences:

A driver whose Kart which emits noise in excess of the designated noise level at any time shall be penalised. They may also be removed from the circuit and not permitted to resume practice or racing until the Officials are satisfied that work has been carried out to rectify the problem.

24.7 Penalties: The recommended penalties for noise offences are:

1. When measuring devices are used;
 - (a) Allowed level plus 1dBA; Penalty 1 point or 1 place penalty.
 - (b) Allowed level plus 2dBA; Penalty 2 points or 2 places penalty.
 - (c) Allowed level plus 3dBA; Penalty 4 Points or 4 places penalty.
 - (d) Allowed level plus 4dBA; Penalty 8 points or 8 places penalty.
 - (e) Allowed level plus 5dBA; Penalty 16 points or 16 places penalty.
 - (f) Allowed level plus 6dBA and over; Penalty of Exclusion from that race, heat, practice session, qualifying session, time trial or similar
2. When measuring devices are not used; **Reserved**
3. Supplementary Regulations may provide for additional penalties.

24.8 Noise Safety:

1. Officials: Every Official or helper who is located close to the track should be issued with ear protection. This can be either earmuff style or disposable foam plugs style.
2. Competitors: it is recommended to wear ear plugs at all times when driving a kart.
3. Pit Area: (In / Out grids and Through grids). It is recommended that all personnel in the pit area use ear protection.
4. Paddock Area: (Where the karts normally are between races). The starting of kart engines in the Paddock area is prohibited.
5. Starting of kart engines in the out grid is only permissible under the instruction of the grid/pit marshal.
6. The promoting club in conjunction with the State Track Safety Inspector will designate a safe area for the starting of kart engines. It is recommended all persons wear ear protection in this area.
7. Spectators - As spectators are in most instances able to enter the Paddock and get very close to the Pit areas, the AKA recommends that Clubs should post signs at all Pit / Paddock entrances advising that ear protection is recommended past that point and advising where ear protection is available.
8. The AKA recommends that Clubs have supplies of disposable ear plugs available at all meetings.

24.9 Noise Emission: To assist in reducing Noise Emissions;

1. For all classes using the Yamaha KT100S Series Engine, it is compulsory that a system is employed to reduce the vibration of the engine's cooling fins. Shrouds wrapping around air cooled engine cylinder and cylinder head fins are not permissible.
2. For all other classes it is recommended that a system is employed to reduce the vibration of the engine's cooling fins.

CHAPTER 25

AUSTRALIAN KART FORMULA

Preamble:

- All karts using any AKA Licenced facility must comply with the relevant contents of this chapter at all times during practice or competition.
- For the purposes of testing and evaluation of equipment not conforming to this chapter the AKA Executive / NKC may permit limited testing under controlled circumstances. For the purposes of this section Rule 13.20 (a) may not apply.

25.01 Chassis:

- (a) **Wheelbase:** Shall be a maximum 1270mm and a minimum of 1000mm. The maximum overall length of the vehicle shall be 1820mm without nose cone fitted. It is forbidden to have any appendage or protrusion which might be hazardous to other vehicles.

Midget and Rookies Class Only: Wheelbase – Minimum 880mm.

- (b) **Track:** Shall measure at least two thirds (66.6%) of the measurement of the wheelbase, and shall be measured between tyre centres.

Maximum kart width for a kart shall not exceed 1400mm.

- (c) **Height:** Maximum height of kart shall not exceed 710mm from the ground.
- (d) **Tyres:** Refer Chapter 23.
- (e) **Wheels/Axle:** Front wheels shall revolve on ball or roller type bearings as separately mounted wheels. Rear wheels to be driven by a one-piece axle shaft. Rear axle must be of steel and the maximum external diameter is 50mm the minimum will be 25mm.

| Nominal axle size (mm) | Internal maximum bore (all tolerance included) |
|------------------------|--|
| 50 mm | 46.25 |
| 40 mm | 36.25 |
| 35 mm | 29 |
| 30 mm | 24 |

Less than 30mm to be solid.

Aluminium axles can be used for speedway and Dirt only. Axles to be 40mm in diameter and have a 4.85m m minimum wall thickness at all points except in key ways.

The number of wheels and tyres is fixed at two front and two rear. Wheels must be secured to the axle by metal nuts or high tensile type bolts. Axle must not protrude beyond tyre. Where axle keys are not the same length as keyway or there is a risk that key may become dislodged, a hose clamp or other positive method of key retention is required.

- (f) **Frame:** Shall be all metal and shall not extend sideways beyond the outside wall of any tyre.
- (g) **Bumper Bars:** Must be fitted and bolted or clamped at all fixing points. Drilling of components for lightening is not permissible. Tube diameter of bumper bar must not exceed 20 mm. On the rear bumper it is permissible to incorporate side extensions (maximum of 2 per side) behind the rear wheels. **Bumpers, either plastic or steel, must be constructed in a manner appropriate for the application in the opinion of the scrutineer.** They must not extend beyond the outside of the rear tyres / rims at any time, wet or dry. They can

incorporate safety rollers (to a maximum diameter of 50 mm) provided that these satisfy the width requirement. All free ends of the bumper and its components to be suitably radiused, plugged or capped to eliminate any sharp areas capable of causing injury.

- (h) Bodywork: The only permissible bodywork or aerodynamic aids are side pods, nassau panels, nosecone and CIK/FIA homologated rear impact protection bodywork.

25.02 Side Pods: Compulsory for All Classes:

- (i) The side pods shall consist of a minimum two side members and a top within the dimensions of the illustration. No part of the side pods may cover any part of the Driver when seated in the kart in his/her normal driving position. When the kart is viewed from *underneath*, the chassis-frame must remain fully visible.
- (ii) Side pods must be a separate item to the undertray.
- (iii) It is recommended that the side pod securing nuts be fitted on the internal surfaces of the pod. If fitted externally no more than approx 2 threads of the bolt to extend past the nyloc nut.
- (iv) Bars on the outside surface of the side pods are not permissible.
- (v) No additional materials or panels are to be fitted to the outside or top surface of the side pods, other than decals or **competition timing equipment as directed**.
- (vi) Side pod mounting bars must be pinned or bolted using minimum 6mm diameter (steel) fixing. Open ends to be radiused. Drilling of metal components for lightness is not permissible. Tube diameter must not exceed 30mm.

CIK Homologated Chassis using springs as their primary method of mounting are required to have a secondary (metallic) method of retention. Minimum of 6mm diameter bolt/pin or multi-strand wire tether through the existing spring mounts.

- (vii) **Dimensions: Side pods:** The side pods must not;

- Be outside the plane passing through the outer edge of the rear wheels, (ref. illustration). This rule does not apply when wet weather tyres are fitted.
- With front tyres in a straight-ahead position, protrude above the plane through the top of the front and rear tyres, (ref. illustration.)

The side pods must have a minimum ground clearance of 25mm. Their outer side must comprise a vertical surface, (with a tolerance of 10 degrees in relation to the theoretical vertical plane,) with a minimum height of 75mm, (immediately above the ground clearance.) The side pod must fill a minimum of 70% of the distance between the tyres.

- (viii) The outside vertical surface of a side pod must be predominantly uniform and smooth, having no additional cut outs or holes other than;

- Those required for their attachment, nominally maximum 6mm screws with "Button" style head only
- a passage for an external starter shaft.
- It may have a 30mm by 30mm (maximum) groove along its length.

- (ix) Side Pods are to be attached at a minimum of two points. With the exception of fixings, transponders and transponder holders, no other items may be placed in or attached to the side pods.

- (x) Material: Side Pods and Nassau Panel:

Shatterproof/non-metallic. Fibreglass must be chopped strand matting type. If plastic, it must be non-splinterable.

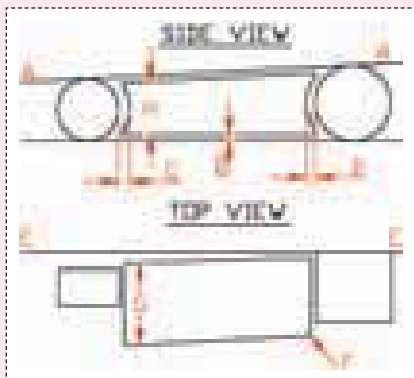

DIAGRAM IS FOR DIMENSIONAL REFERENCE ONLY

- A-A = With the front tyres in a straight-ahead position, must not protrude above the plane through the top of the front and rear tyres.
- B = 25mm minimum
- C = deleted
- D = 60mm maximum
- E-E = Must not be outside the plane passing through the outer edge of the rear wheels. This rule does not apply when wet weather tyres are fitted.
- F = Corner radius, 5mm minimum.
- G = 50mm minimum.
- H = 75mm minimum.

25.03 Nassau Panel:

Are compulsory, and they are to be no wider than 300mm (bitumen) or no wider than 500mm (dirt) and no higher than the top of the steering wheel and do not restrict the driver. Legibility of race numbers must be maintained

NASSAU PANEL DRAWING

DIAGRAM IS FOR DIMENSIONAL REFERENCE ONLY

I = 50mm min

J = 300mm max (bitumen)

K = 500mm max (dirt track)



25.04 Undertray:

Shall be of non-perforated sheet of a minimum 0.5mm in steel or 1.2mm in aluminum or carbon fibre or 2mm in fibreglass and shall have no void large enough to permit any part of the driver's body to pass through. Securing nuts may be fitted above or below the floor pan, no more than approximately 2 threads of the bolt to extend past the nyloc nut. Undertray must not extend beyond the inside of the chassis rails.

25.05 Steering:

1. Shall be effected by the operation of a full wheel or aircraft type wheel, but must have a continuous outer rim. Straight handlebars are forbidden.
2. The steering wheel boss is to be manufactured of metal and attached with minimum of 6mm high tensile bolt and be fitted with self-locking nut. The 6mm bolt must be fitted in a fore and aft position with the locking nut at the lower aft end of the steering boss. Plastic components are forbidden, the exception being the unmodified Rotax Steering Boss (part number 660 640).
3. Steering shall be direct acting through a steering shaft of 16mm minimum diameter if solid or minimum 18mm diameter, if tubular, having a minimum wall thickness of 1.5mm and be constructed of steel. The shaft shall be welded or bolted with a mating collar for steering wheel attachment. The steering shaft shall have a collar / retaining device, to be securely fitted within 5 mm of the lower edge of the upper steering shaft bush.
4. All bolts must be a minimum of 8mm in diameter for king pin & rod ends. All these bolts to be of strength class of 8.8 or greater and be fitted with self locking nuts.
5. The tie rods are to be a minimum 8mm OD steel rod or 10mm OD by 2mm steel tube or minimum 10mm OD aluminum alloy rod or equivalent or 12mm OD by 2.6mm aluminum alloy tube or equivalent. An engaged thread length minimum 8mm is required between tie rod and rose joint. Rose type joints of peg, plastic/nylon and/or pressed metal type are not permitted.

25.06 Front Fairing (Nose Cones):

Nose cones are compulsory in all classes.

- (a) Nose cone must comply with the **measurements and diagram outline** in every respect.
- (b) No strengthening pieces or support permitted.
- (c) Material: Plastic only.
(Must be non-splinterable and non-shatterable).
- (d) Nose cone to be attached to chassis with the manufacturers supplied fitting only.
Any temporary repairs to be approved by chief scrutineer.

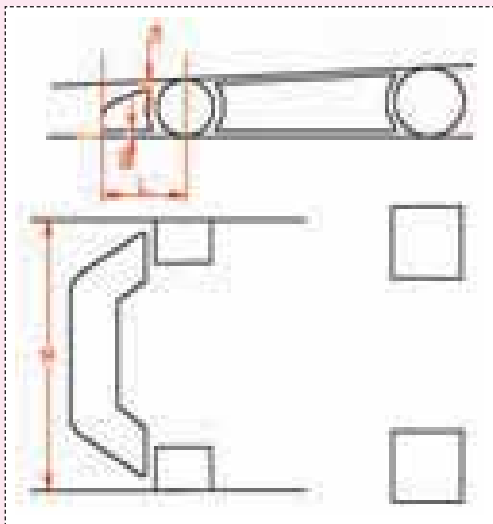

DIAGRAM IS FOR DIMENSIONAL REFERENCE ONLY

- A = With the front tyres in a straight-ahead position, must not protrude above the plane through the top of the front and rear tyres.
- B = 25mm minimum
- L = 650mm maximum.
- M = Must not protrude outside the plane passing through the outer edge of the front wheels in their straight ahead position. Minimum dimension will be 500mm

25.07 Brakes:

The brakes must be effective and work on at least both rear wheels simultaneously.

1. Braking of the rear wheels ONLY except
 - (a) the following classes: 125 gearbox, Intercontinental C, Open Class and with 2 stroke engines having a total capacity of 125 cc or greater capacity.
 - or
 - (b) if detailed in class technical chapter.
2. Rear brakes must be foot operated through the two rear wheels, front wheel brakes may be hand operated.
3. For twin engine karts a dual rear brake system is recommended.
4. Disc brakes only. May be hydraulic or mechanically operated.
5. All brake system mounting bolts and studs must be of high tensile material. The brake pedal must not protrude past the vertical plane of the forward most part of the front crash bar when operated.
6. All brake pad mounting bolts must be of high tensile material and fitted with a sleeve. Shoulder type bolts are not permitted.

- Where brake pads are retained only by bolts, the bolts must be drilled and safety wired with quality tie wire or if split pins are used they are to be in manufactured condition with a minimum diameter of 3mm.
- Nylon brake hoses must use metal fittings.
- All brake cables must be multi-strand steel wire of 2.25mm minimum diameter and must be fastened by a machine swagged fitting or by positive methods that cannot cut into the wire. Electrical connectors or similar are not permitted.
- Brake pedal rods are to be a minimum of 6mm diameter solid steel if the threaded ends are cut into the rod or 5mm solid steel if the threaded ends are rolled on the end of the rod.
- All fasteners must be safety wired or fitted with self-locking nuts.
- All hollow pins must be wired or pinned.

Safety Notes

- The use and handling of Cadmium plated parts and asbestos is considered by the National Health and Medical Research Council to be cancer causing.

25.08 Exhaust Header Pipe

Exhaust Header Pipe: Formula Australia, Clubman, National 100cc, Midgets, Rookies.

This item is not restricted to the original Manufacturer but must conform to the type (style) and of the original header pipe. Inside diameter must be parallel.

Minimum Length permitted 120mm (as per diagram below)

Maximum inside diameter of 36mm.

Minimum inside diameter of 34mm. Refer diagram

It is permissible to stiffen the exhaust flange to the extent shown in the drawing.

The maximum length from the engine side face of the flange to the end of any stiffening is 20mm

Any stiffening must not interfere with the fitting of exhaust seals.

Modifications to fit an exhaust probe are permissible. Refer Rule 25.09.

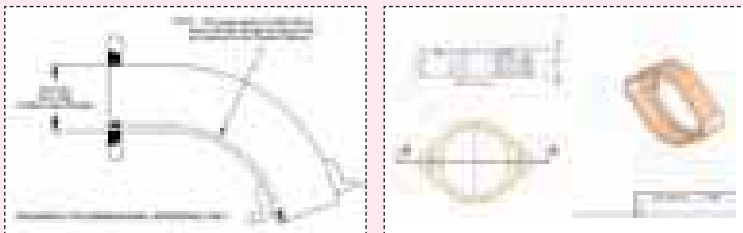

25.09 Exhaust System:

- Must be such as to carry the exhaust gases away from and to the rear of the driver.
- Exhaust gases must all pass through the exhaust header pipe and the muffler and silencer (if mandatory) at all times.
- Mufflers must conform to Rule 24.2 with respect to noise level. (Supplementary Regulations may allow for a lesser noise level.)
- The open end must point in such a way so that it does not present a hazard to other drivers.

- Muffler must be securely fastened with springs to a mounting bracket cradle and to the header pipe of the engine. A secondary fastening system, comprising a multi-strand wire (as used in throttle cables) to be secured through a fixing lug or a similar attachment (e.g. hose clamp) on the muffler and fixed to the chassis, excluding rear bumper bar to prevent the exhaust system detaching from the kart.
- It is permissible to use, externally, heat proof wrapping between the springs and exhaust cradle and the springs and flex.
- A maximum of one (1) Exhaust probe/fitting is permitted. The maximum diameter of the probe is 6mm. Maximum length of exhaust probe is 25mm

25.10 Throttle:

Must be foot operated only. The throttle pedal must not protrude past the vertical plane of the forward most part of the front crash bar when operated. When released must shut off air fuel mixture passage sufficiently to reduce engine revolutions to an idle speed. Butterfly throttles must be fitted with two return springs, both able to shut off throttle if one should fail. It is recommended slide valve throttles be fitted with a secondary method of closing.

25.11 Guards:

- Chain Guards:** A chain guard is compulsory and must give sufficient front and side protection to prevent the driver trapping his/her fingers in the chain.

The OEM engine sprocket guard for the Parilla Leopard and the SQ Cheetah 125 may be modified as per the following diagram. The corners may be radiused to a maximum of 10mm.

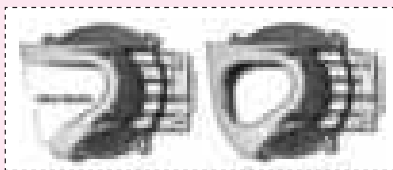

- Engine Sprocket Guards:** An engine sprocket guard is compulsory and must give sufficient front and side protection to prevent the driver trapping his/her fingers in the chain.
- Skid Plates or pads are permissible, but must be of non metallic material. Skid Plates and/ or guards that pass under the brake disc or engine sprocket and chain are prohibited. Any brackets that support such skid plates or pads cannot be lower than the skid plate or pads. Side plates or discs that are attached to the sprocket or carrier and are larger than the outside of the chain are also prohibited."**

25.12 Seating:

Shall be designed to minimise the likelihood of the driver sliding Sideways. It is recommended a metal plate 35mm minimum diameter of 1.5mm thickness be placed between seat and stays.

25.13 Numbers:

- Identifying numbers shall be displayed so they are clearly legible and shall be maintained in this condition throughout an event in which the kart is competing. Identifying numbers shall be restricted to either one or two digit numbers. The number 0,00 or any number proceeded by 0 (e.g 05) is not allowed.
- In the event of two karts with the same number competing in any one Class at any event where numbers are not allocated by the Organisers, the home driver will be issued with a special number by the Organisers.

3. Front and rear numbers must be a minimum of 130mm high and a minimum of 20mm thick, and be of plain or italic font similar to the sample below. They must be of the appropriate colour, and be placed on a full rectangular background of the appropriate colour, and have a minimum of 15mm to all edges of the background. For double digit numbers, there must be a minimum of 15mm spacing between numbers. The background colour must be a continuous unbroken rectangle, without highlight lines or contoured borders.
4. Side numbers are required to be mounted on both sides of the kart on the outside surface of the side pods. They must be a minimum of 100mm high and a minimum of 15mm thick, and be of plain or italic font similar to the sample below. They must be of the appropriate colour, and be placed on a full rectangular background of the appropriate colour, and have a minimum of 15mm to all edges of the background. For double digit numbers, there must be a minimum of 15mm spacing between numbers. The background colour must be a continuous unbroken rectangle, without highlight lines or contoured borders. Where a hole is required in the outer surface of the side pod for external starters, the hole must not break into the rectangular background

| | | | | | | | | | |
|----------|----------|----------|----------|----------|----------|----------|----------|----------|----------|
| 1 | 2 | 3 | 4 | 5 | 6 | 7 | 8 | 9 | 0 |
| 1 | 2 | 3 | 4 | 5 | 6 | 7 | 8 | 9 | 0 |

5. Number plates shall be flexible plastic material with a flat surface large enough to carry the number and all corners of the number plates must be radiused. They shall be colored as follows;
 - Senior Classes: Yellow number plate with black numbers
 - Junior Classes: White number plate with black numbers.
 - Rookie and Midget Classes: White number plate with red numbers.
6. The number plates (and/or the Nassau panel numbers area) must be mounted on the front section of the kart, and on the rear bumper so that it will not pivot up or down.
7. National Sprint Champions: Refer Rule 20.16 (d).
8. State Sprint Champions: Refer Rule 20.33 (e).
9. State Closed Title winners: Refer Rule 19.17(b).
10. PROVISIONAL Licence Holders shall have a State Traffic Authority regulation (red and white) "P" plate on the front and rear of their karts, clearly visible.
11. Class winners of any breast cancer foundation ladies only competitions are allowed to use Pink number plates for the period of their reign in the class that they were awarded in.
12. The Chief Lap Scorer, Chief Scrutineer & Clerk of Course decision as to legibility of numbers is final.

25.14 Chain Oilers: Only permitted on Dirt Tracks. (Optional to Promoters).

25.15 Suspension:

- (i) Any suspension device, either elastic or hinged, is prohibited.

25.16 Communication and Telemetry:

- (a) Radio communication, mobile phones and telemetry aids with the exception of official timing equipment are not permitted to be used by drivers during competition.
- (b) The use of any type of camera on a kart during practice or racing at any permitted race meeting is banned. For promotional purposes only, permission may be requested from the relevant SKC in consultation with the State Technical Officer.

25.17 Engines and Transmission:

- (a) Type of engine shall be 2 or 4 cycle.

Modifications to engines are only permissible where stated under Class Specifications.

IF THESE RULES DO NOT SAY YOU CAN MAKE A MODIFICATION, THEN YOU CAN NOT.

Any reference to any earlier publication or correspondence and any other written, verbal or electronic material cannot be used as evidence against the current AKA Manual.

- (b) Any accidental engine damage, internal or external, that may possibly breach a class chapter rule is acceptable if it is judged by the State Technical Officer to not offer a performance gain. Timed port edge damage must pass the Piston Travel Gauge test.
- (c) Transmission System: Forbidden in all classes EXCEPT gearbox classes and Open Class.
- (d) Front Wheel Drive systems are forbidden.
- (e) Clutches:

The fitting of a clutch assembly is optional except where stated in class regulations.

All clutches, including axle clutches, must be dry centrifugal type only, must be AKA registered and can only be run on the engines they have been registered for.

- (f) All clutches must have fitted a guard or retention device to prevent the clutch mechanism from leaving the kart in the event of a component failure. The guard or retention device must be "fit for purpose" and bolted to the engine in a minimum of two places.
- (g) All engines fitted with a clutch must have an ignition kill switch. The switch is to be wired into a circuit loop so that when operated it will effectively bring the engine to a complete stop. It is permissible to cut into the wiring harness to connect a kill switch. It must at all times be operational whilst the engine is in use. It can be inspected at any time for compliance and effective operation
- (h) Belt drives are permitted on all classes, except where the registered engine or clutch will not accept the belt drive system without modifications.
- (i) It is permissible to externally start any AKA homologated/registered engine with a starting system in the event of a starting system failure. Engines registered with attached starting mechanisms must have those mechanisms in place.
- (j) All clutches must engage sufficiently to allow front wheels to climb test bar at less than 4800rpm.

Checking the movement of the kart at the set rpm will take place on either the dummy grid or on the track before time trials/ qualifying and /or races. A strip of metal (10mm high by 75mm wide by 1300mm long) will be placed on the ground immediately in front of both front wheels. The engine will be started, the Technical Officer will pinch the cable of the revolution counter to the spark plug cable to read the number of revolutions. The driver must obey the orders given by the Technical Officer.

The procedure is as follows:

1. The driver must keep the engine running.
2. The brake pedal must remain in the free position without any pressure
3. The driver shall accelerate with a smooth and light gradual pressure on the accelerator pedal to allow the technical officer to read the rpm at the moment when the front wheels move up and over the strip and the rear wheels travel one revolution.
4. In the case of the clutch not engaging at or before the 4,500 set rpm, a second check will be done immediately.
5. If the clutch is not engaging at or before the 4,500 set rpm on the second check, the clutch will be deemed to be non-compliant, resulting in the issue of a Penalty Notification Form pertaining to rule 25.17(j) with a penalty of exclusion from that section of the event.
6. It is not permissible to increase tyre pressures on the out grid after the above test, if the above test was conducted on the out grid prior to that tested class proceeding to their next race heat.

(k) Compatible Clutch Table

| | COMER SW80 | YAMAHA KT100 J | YAMAHA KT100 S SHORT SHAFT | YAMAHA KT100 S LONG SHAFT | YAMAHA KT100 SEC | ARC SPEC 100 A | ARC SPEC 100 W |
|--|------------|----------------|----------------------------|---------------------------|------------------|----------------|----------------|
| COMER PART NO. S80 3950 01 | X | | | | | | |
| TOMAR TD22 AKA # 56 | | X | | X | | | |
| STRIKE SSS SL for YAMAHA KT100 J ONLY AKA # 38 | | X | | | | | |
| STRIKE SSS SL (SHORT SHAFT) AKA # 45 | | | X | | X | X | X |
| STRIKE SSS EVOLUTION (LONG SHAFT) AKA # 47 | | | | X | X | | |
| FREELINE AKA # 44 | | | X | | X | | |
| ITAL RED (LONG SHAFT) AKA # 55 Spec 3 Taperlock Spec 4 Taperlock | | X | | X | | | |
| ITAL RED S (SHORT SHAFT) (SPEC 1, SPEC 2, TAPERLOCK) | | | X | | X | X | X |
| ARC OEM | | | | | | X | X |
| YAMAHA 7YPS AKA # 57 | | | | | X | | |
| ZEDTEC ZD1 X | | X | X | X | X | X | X |
| DRIVE BELT PULLEY TO SUIT STRIKE SSS CLUTCH ONLY AKA # 52 | | X | X | | | X | X |

25.18 Liquid Cooled Motors:

- (a) Any water-cooled version of a currently accepted air-cooled engine will require its own registration and /or homologation. (See Chapter 21)
- (b) All karts with water-cooled engines if not fitted with a sealed cooling system must be fitted with a catch tank of a minimum 100ml capacity to retain radiator overflow.
- (c) Glycol base or soluble oil coolants are prohibited. Liquid used in liquid cooled engines may be subjected to an AKA approved test to determine if Glycol or soluble oils are present. Anti freeze hydrometer and litmus paper are approved methods.
- (d) Radiator(s) are not permitted to be located further forward than the steering wheel.
- (e) Air flow restriction devices must stay affixed to the kart at all times.
- (f) A reference in this manual to Water - Cooled is to be taken as reference to Liquid – Cool.
- (g) All overflow bottles to be empty prior to the kart entering the out grid.

25.19 Weights:

- 1. Class Weights are as raced at the time of weight measuring, and are detailed in technical pages of the classes. Weight that is more than 5kg must be retained by a Minimum of two 8mm high tensile with lock nuts.
- 2. Maximum Kart weights at time of weighing for all Junior Heavyweight, Senior Heavyweight and Senior Super Heavyweight Classes to be 88kgs except where: a) noted in class technical detail e.g. all heavy 125 classes maximum kart weights of 100kg or b) when a lighter weight division of a class is not being run at a race meeting.
- 3. All weights to be securely fastened to the Kart with a minimum 8mm high tensile bolt and lock nut. Large widths may require additional high tensile bolts.
- 4. Weights must be attached to the frame or the seat only.
- 5. No ballast weight to be attached to steering components and rotating parts.
- 6. Lead shot, as a weight, is banned
- 7. Competitors must use the scales supplied by the Promoters to assess the racing weight of their equipment.

25.20 Exotic Compounds

Carbon Fibre compounds may only be used in seats, Nassau panels or floor trays. Carbon fibre floor pans must be a minimum of 1.2mm thick. Refer rule 25.04.

25.21 Non-Tech Items

- (a) Non-tech items are gaskets, seals, big end roller/cage, little end spacers, rings, washers, cages, fasteners, fulcrum spring (carburetor meter levering spring), spark plug and spark plug lead and cap, gudgeon pins, main bearings, coolant sealing "O" rings, engine sprocket and key.
 - 1. Unless specified, non-tech items are to be of the same type and style as the original. No alteration from the original manufacturer's specifications is permitted to fit a non-tech item
 - 2. Head gasket/s must be retained
 - 3. Cylinder base baskets are dimensionally free
 - 4. Carburettor base and phenolic spacer gaskets are dimensionally free
 - 5. Only crankcase half gasket may be formed from liquid gasket compounds
 - 6. Cylinder base adjusting shims/spacers may be of any material and must be of uniform thickness.

7. Spark plugs must have a maximum engagement length of 20mm without the washer.
8. Spark plugs for Comer SW80 must have a maximum engagement length of 1/2 inch (12.70mm) without the washer.

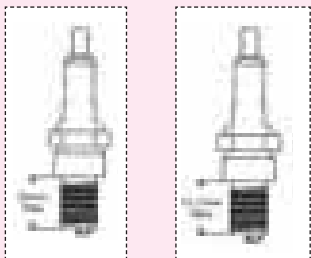

9. A direct drive sprocket (complete) cannot weigh more than 100 gms.
10. A direct drive sprocket retaining nut cannot be made from a hex material greater than 19mm AF.
11. Pull start and electric start systems are non-tech.

25.22 Exhaust Mufflers:

1. General / All Classes

- (a) All karts must use exhaust mufflers and comply with noise regulations as per Rule 24.2.
- (b) No device capable of being moved whilst racing is permissible in or on the exhaust.

2. AKA Controlled Mufflers



Dimensional References:

Unless specified as a maximum measurement, the following dimensions are subject to Rule 26.02 General Tolerances.

| Reference | Description | AKA 14 | AKA 39 |
|---------------|--|-------------|--------------|
| A | overall length | 650mm | 675mm |
| B | internal tail pipe length | 38mm | 38mm |
| C | tail pipe to baffle length | 512mm | 512mm |
| D | tail pipe to deflector length | 422mm | 422mm |
| E | exhaust outlet hole position | 52mm | 112mm |
| F | end cap to baffle | 47mm | 47mm |
| G | maximum diameter outlet hole | 19.4mm max | 26.3mm max |
| H | circumference | 280mm | 280mm |
| I | "internal diameter" tail pipe inlet | 46.0+/- 1mm | 46.0 +/- 1mm |
| J (not shown) | maximum diameter of internal baffle plate hole | 4.5mm max | |
| K | end cap length | 123mm | 148mm |
| L | inlet pipe to first weld (cone length) | 158mm | 158mm |

(a) 100cc National - Senior and Junior, Rookies, Midgets

The only permissible exhaust muffler for classes using the KT100J Engine is the control pipe AKA 14 manufactured by Powermac. The AKA 14 exhaust pipe carries precise dimension specifications that allow confidence in equality of performance for all competitors using the KT100J series engine.

(b) 100cc Clubman (Senior and Junior), 200 Clubman.

The only permissible exhaust muffler for classes using the KT100S, KT100SE, KT100SD and KT100SEC Engine is the control pipe AKA 39 manufactured by Powermac. The AKA 39 exhaust pipe carries precise dimension specifications that allow confidence in equality of performance for all competitors using the KT100S series engine.

- (c) Any measurement related to weld at either end of the cone will be taken to the centre line of the weld.
- (d) All other dimensions not specified carry stringent technical specifications. Any attempt to alter these dimensions will deem the unit illegal.
- (e) Any accidental damage (when all gasses still pass through the exhaust system as per rule 25.09.2) will not incur a technical breach of these rules.
- (f) It is permissible to weld a fixing lug to the external surface of the AKA 14 or AKA 39 body.
- (g) With the exception of repair to fixing points, any attempt to repair damage by cutting, welding or fabrication will automatically remove eligibility of the exhaust unit.
- (h) For Classes subject to AKA 14 & AKA 39 Control exhaust pipes. The exhaust header pipe and muffler can be joined by a pipe or flexible tube with a parallel bore in the section through which the exhaust gases pass and be of constant wall thickness and must have substantially square, flat and functional sealing end faces with a minimum 36mm ID maximum 46.5mm OD. Exhaust spacers are allowed and must be of material equal to the permitted size of the joining exhaust flex or pipe, be of parallel bore, and must have substantially square, flat and functional sealing end faces
- (i) An "R" end-cap for the AKA39 control pipe is not permitted to be fitted to an AKA14 "J" body and an "R" end-cap for the AKA14 control pipe cannot be fitted to an AKA39 "S" body.

For information and clarification of 25.22.2(i)

- An AKA39 complete exhaust unit is identified by an alphanumeric stamp on the main body at the inlet end, and on the end-cap. (Eg: S00123456)
- An AKA14 complete exhaust unit is also identified by an alphanumeric stamp on the main body at the inlet end, and on the end-cap. (Eg: S00123456)
- An AKA39 end-cap replacement is identified by an alphanumeric beginning with R on the end-cap (: Eg R123456)
- An AKA14 end-cap replacement is identified by an alphanumeric beginning with R on the end-cap (: Eg R123456)
- A pre alpha numerical AKA14 complete exhaust pipe is identified by the AKA14 stamp on the main body of the pipe and the end-cap and is eligible for competition.
Competitors are requested to check their exhaust pipes for compliance with the new regulation.

3. Other Classes

- (a) For reed and rotary valve engines any CIK homologated muffler is permitted
- (b) For all other classes, if not specified within class regulations they must conform to Rule 25.09 and Rule 25.26.1.

25.23 Reserved

25.24 Noise Induction Silencer:

1. AKA43 "Stock" Noise Induction Silencer.

- (a) The "AKA43" noise induction silencer is compulsory and is the only unit allowed for Midgets, Rookies, National, Formula Australia, Clubman, Yamaha Tag 100, PRD and ReSa Classes, and optional for Parilla Leopard.

- (b) The "AKA43" noise induction silencers are units where induction shall be via two (2) only inlet tubes 23mm maximum diameter at the opening and 95mm min length and fitted to the airbox in a nominal fore and aft direction.
- (c) The "AKA43" noise induction silencer is identified with 'AKA43' moulded in the top & AKA-KIAA lettering moulded into the flat sided face.
- (d) The "AKA43" noise induction silencer must be used with the AKA43 internal filter element.
- (e) The AKA43 internal filter element cannot have any holes, tears or cuts in it.
- (f) The element must be as moulded direct to the rubber adaptor.
- (g) The only internal filter that can be used for sprint racing is marked "AKA43".
- (h) The rubber adaptor is black in colour and the filter element is blue.
- (i) The internal filter for Dirt track karting and Speedway will be marked "AKA43".
- (j) The rubber adaptor will be black & the filter element will be yellow.
- (k) All inducted air must pass through the baffle tube/s into the Induction Silencer and to the carburettor via a sealed connection.
- (l) Filter screens may be fitted to reduce entry of foreign matter.
- (m) Air tubes may be partly or completely blocked at the entrance hole only, and the restriction component must be easily removed for inspection
- (n) No adjustable systems are allowable
- (o) Any item that in the opinion of the user will prevent water from entering the engine whilst wet conditions are declared / announced, is eligible.
- (p) It is permissible and advisable to secure the air inlet tubes into the air induction silencer body with an adhesive.
- (q) It is permissible to drill extra holes in the side flange for mounting purposes.

2. Other

- (a) All other classes may use any AKA registered units and units that have been specifically outlined in class chapters.
- (b) Righetti Rodlfi K560/22 is for Leopard Class.
- (c) Square style socoremm – Minimum tube length 94.5mm
- (d) JICA, ICA, FA and ICC are required to use CIK registered units.

25.25 Noise Induction Silencer Adaptor:

1. Induction silencer adaptor must conform to the specifications of the diagram.

NOISE INDUCTION SILENCER ADAPTOR DIAGRAM
DIAGRAM IS FOR DIMENSIONAL REFERENCE ONLY

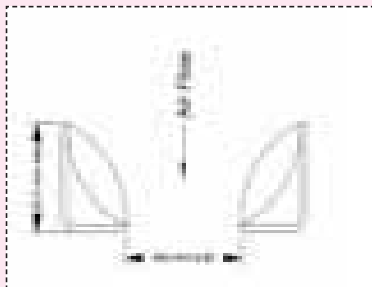

2. The following classes: Open; Formula 100; Parilla Leopard 125 and Piston Port are exempt from rule 25.25
3. For Midget Class, where competitors are using the Comer S80 Engine refer Rule 41.12.

25.26 Carburetor for Yamaha KT100 J and Yamaha KT100 S

Must be Walbro WB series conforming to dimensions as per diagram.

(Note – WB 24 is not eligible)



DIAGRAM IS FOR DIMENSIONAL REFERENCE ONLY

- (a) It is permissible to machine the Walbro carburettor body to
 - (i) conform to dimension E
 - (ii) conform to dimension C
 - (iii) accept an O ring for the low speed jet and throttle shaft.
- b) A threaded butterfly screw must be retained, countersunk screws are not permitted. Butterfly and shaft must be as manufactured.
- c) It is permissible to repair the inlet seat and throttle shaft bore in the Walbro carburettor. Carburettor bore may not be sleeved.
- d) It is permissible to enlarge only existing fuel / air holes, but they may not be deleted or relocated. The holes must be the same shape as originals when viewed externally.

- e) All air must pass through the carburettor throat.
- f) Measurement code:
 - A As cast MAX Venturi diameter 24.13mm
 - B As cast (area will extend from the front of the carburetor to the progression discharge jet which must have all or portion of this jet in the cast area.)
 - C MAX downstream diameter 25.7mm
 - D Butterfly shaft must be located at the bore centre.
 - E MIN carburettor body length of 37.5mm

No internal inspection required, ie covers will not be removed and only external measurements and visual inspection taken.

25.27 Batteries

Starting and ignition batteries when fitted must only be attached to the chassis or seat and be securely mounted. The only batteries permissible are Dry Cell, Gel type or Valve regulated sealed lead acid batteries. All external starters using vented batteries must be fitted with an external overflow/catch bottle minimum of 50ml

The battery must be contained in:

- (a) A four-sided bracket or box with a min height of 10mm.
- (b) The bracket or box must be secured to clamps or brackets that are fixed to the chassis or the seat and must be secured with a minimum of 4 x 6M bolts or 2 x 6M 'U' clamps.

The battery must be secured in the bracket or box by at least one (1) of the following:

- (a) A suitable top clamp fixed with 2 x 6M bolts.
- (b) A minimum 15mm wide strap with buckle fastener or rubber grommets
- (c) 2 UV Rated zip ties with a min. width of 7.5mm and be at least 2mm thick.
- (d) A 50mm wide Velcro strap

Straps and Zip ties are not to pass over any sharp edges or under the Kart frame.

25.28 Ceramic bearings

The use of ceramic bearings is NOT permitted. No rotating ceramic parts are permitted.

25.29 Parity.

Performance Parity Adjustment may be undertaken by National Technical Committee at short notice and at such times as considered necessary. Their recommendations will be presented to the NKC for consideration and/or approval.

25.30 Transponder fitting instructions:

AMB TranX transponders must be mounted in the appropriate bracket on the side pod of the kart, no more than 30cm above the track surface and approximately 30cm behind the king pin line of the front of the kart. It is recommended that the transponder is mounted vertically and that there be no metal or carbon fibre between the bottom of the transponder and the track surface.

25.31 Cameras on karts:

Cameras are permitted on karts providing they conform to the following:

1. A camera or self contained camera unit cannot weigh more than 300gm (including any associated mounting bracketry), but if a camera with a separate recorder is used, then the camera (and any intergrated cabling) itself cannot weigh more than 200gm and the recorder (including any other cabling, batteries, etc) cannot weigh more than 1kg. Should there be any question on the weights, the competitor must be able to supply evidence that the maximum weights have not been exceeded.

2. The camera must be mounted to the kart with a “fit for purpose” mounting system that, in itself, does not pose a hazard to other karts or karters under any circumstances.
3. No more than one camera can be mounted on the Nassau panel at any one time. attachment must not be dependent on any tension in the tether cable.
4. The camera itself must be secured to the kart using a multi strand tether wire or cable ties securely attached to the camera and an adjacent tie point on the kart frame (this does not include any plastics or seat).
5. If a separate recorder is used, it must be mounted on either the chassis or the seat only and cannot be mounted on the Nassau panel.
6. If a separate recorder is used, this must be securely mounted in a “fit for purpose” cradle. Any connecting cable between the recorder & camera must be routed in such a way that it will not interfere with a driver entering or exiting the kart.
7. The camera or recorder cannot be mounted on the helmet or any safety apparel.
8. The camera cannot be mounted any higher than the top of the steering wheel.
9. The direction the camera faces is free.
10. No optical flashing function is allowed.
11. Maximum of TWO cameras to be used at one time

CHAPTER 26

GENERIC COMPLIANCE CHECKS

Technical Inspectors are only there to check motors with gauges for compliance, NOT to measure them.

26.01 Cylinder Head Volume Measurement:

The measuring fluid will be a solution of 50% diesel and 50% auto transmission fluid. **To be measured by use of a glass A or B grade burette**, To be measured by use of 'B' Grade Burette maximum capacity 50cc (recommended 25cc), calibrated to a minimum 1/10th of a cc. under gravity feed.

It is the competitor's responsibility to supply an engine (as raced) with a spark plug thread in a condition that allows the easy fitment of a cc plug. Penalty, Non-conforming engine.

Method

1. Remove spark plug and insert AKA CC Test Plug.
2. Place piston at approximately TDC.
3. The CC Test Plug to be withdrawn two turns.
4. Insert the required volume of measuring fluid; make sure the fluid is visible in the CC test plug.
5. Tighten CC Test Plug down until it stops.
6. Slowly wind motor over and check for fluid level in CC Test Plug. (as shown in diagram). (Note: Motor to be measured should be allowed to cool to ambient temperature and no fluid shall be expelled through the top of CC Test Plug.)
7. Should the first test fail, the competitor may request a second test.
This test to repeat Items 1 to 6 above (after Step 8).
8. To clean out measuring fluid after failure of first test and before commencement of second test, unleaded petrol to be poured into cylinder, motor to be rinsed and blown out by inserting air hose into spark plug recess and turning piston to open exhaust. Therefore, expelling excess fluid.
Cylinder Head and Engine Seal is not to be removed prior to any CC test.
9. CC TEST GAUGES

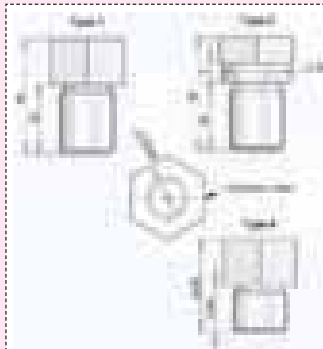

TYPE 1.

| HEXAGON | APPLICATION | COMMENTS |
|--|--|----------|
| ¾ (19.05 mm) or 13/16 inch (20.64 mm) AF | This applies to all 20mm plug length engines, including KT100J, KT100S, ARC, Leopard, Fireball | |

TYPE 2.

| HEXAGON | APPLICATION | COMMENTS |
|--|---|--|
| ¾ (19.05 mm) or 13/16 inch (20.64 mm) AF | This applies to all 20mm plug length engines, including KT100J, KT100S, ARC, Leopard, Fireball and Rotax Max & Jmax | Specifically designed for Rotax Max and Jmax by incorporating a relief to clear water jacket cover. It is permitted to modify Type 1 gauges to incorporate this relief |

TYPE 3.

Deleted 2008

TYPE 4.

| HEXAGON | APPLICATION | COMMENTS |
|---------------------------------|-------------|-----------------------------------|
| ¾ inch (19.05 mm) AF preferably | Comer SW80 | ½ inch (12.7 mm) reach spark plug |

General Tolerances applied to all CC Test Gauges:

All gauges must conform to the following specific tolerances:

The CC Test Plug is available from your State Secretary.

| FEATURE | TOLERANCE (mm) |
|----------------|-----------------|
| Overall length | -0.00 to +0.05 |
| Thread length | -0.05 to +0.00 |
| Bore | -0.00 to +0.015 |

NOTE:

- It is the competitor's responsibility to supply an engine (as raced) with a spark plug thread in a condition that allows the easy fitment of a cc plug. Penalty, Non-conforming engine.
- The CC Test Plug is available from your State Secretary.

26.02 General Tolerances

Unless otherwise specified, the following tolerances will apply to all dimensions and any references to Maximum or Minimum mean the absolute dimension for that item.

| Dimension | <25mm | 25 – 60mm | >60mm |
|------------------------------------|----------|-----------|---------|
| Machined Parts | ± 0.05mm | ± 0.15mm | ± 1.5mm |
| Non machined / raw or welded parts | ± 1.0mm | ± 1.5mm | ± 3.0mm |

26.03 Measuring Engines Controlled by Exhaust Port Timing

Insert either the 5mm rod or where required the 0.2mm feeler gauge, which has been cut down to a point, into the uppermost point of the exhaust port at the intersection of the port opening and the piston. This will give the opening point of the exhaust port. Measure stroke from this point to TDC using a dial indicator inserted through the spark plug hole. This measurement will give the minimum piston travel that can be cross-referenced against the charts in the relevant section.

26.04 Port timing Check with AKA Piston Travel Rods

Note: The PTG rods are available from your State Secretary

Piston port engines (KT100S, KT100J, ARC SPEC 100 & ARC A1) will have PTG rods in the future with 5 grooves AND Reed valve engines (Rotax MAX, Parilla Leopard & PRD Fireball) will have PTG rods in the future with 4 grooves to allow the checking of the exhaust transfer split. Currently these rods have only 4 & 3 grooves respectively. It will be necessary to use the 5 mm AKA transfer port checking tool for this measurement

Step 1. Set Gauge

Screw the body unit of the Piston Travel Gauge into the spark plug hole and insert the rod for the type of engine being checked.

Note: The rods are engraved on the head with S for KT100S & Formula Australia engines, J for KT100J engines, R for Rotax Max, JM for JMA, L for Leopard, F for Fireball engines & A for ARC A1 (inc. M1 & R1) engines.

Turn the engine in its direction of rotation till the conrod reaches its highest point of the engine stroke TDC, adjust the head of the gauge body to line up with the bottom mark of the rod.

Step 2. Check Stroke

Slowly turn the engine in its direction of rotation till the rod is at its lowest point BDC and the top mark on the rod should line up with the head.

Step 3. Check Exhaust Duration

Place the 5 mm pin in the top of the exhaust port and slowly turn the engine in the direction of rotation until the top of the piston touches the 5mm pin which is then "rolled" between the top of the piston and exhaust port to find the highest point of the exhaust port. Using very light pressure to hold the pin in place, the second top (or third from the top if the rod has 5 grooves for KT100S, KT100J, ARC Spec 100 & ARC A1 (inc. M1 & R1) engines and 4 grooves for Rotax MAX, JMA, Parilla Leopard & PRD Fireball engines) mark on the gauge rod should not be showing or is in line with the head of the gauge body. If the line is above the head of the gauge body, the engine does not conform.

Note:

early model KT100S engines have one side of the Exhaust Port slightly higher than the other. When checking the exhaust on the Comer SW80, Rotax Max 125, Rotax JMax, Fireball, Leopard, X30 & Cheetah, the exhaust checking groove (3rd groove down from top of rod) is narrow to define maximum and minimum exhaust duration. Hence, when checking the exhaust with the Ø5mm pin in place, the top of the gauge body must lie within the width of this (3rd) groove.

Step 4. Check Exhaust /Inlet Port Split

(only applicable to KT100S, KT100J, ARC SPEC 100, ARC A1 & Comer SW80 engines). Maintain the 5mm pin in the exhaust port, adjust the head of the gauge unit until it lines up with the bottom edge of the groove used for checking the exhaust, then remove the pin from the exhaust port. Turn the engine to TDC and insert the 5mm pin into the inlet port and turn engine slowly until piston comes in contact with 5mm pin which is to be "rolled" between the bottom of the inlet port and the piston skirt to find the lowest position of the piston, the third line on the rod should be above the head of the gauge body or in line. If it is below the piston is too short and does not conform.

Step 5.

Check exhaust/transfer port split when using a rod with 5 grooves (for rods for KT100S, KT100J, ARC SPEC 100, ARC A1 & Comer SW80 engines) or 4 grooves (for rods for Rotax MAX, JMA, Parilla Leopard, Cheetah SQ & PRD Fireball engines)

After step 3 (with the gauge body still set for the exhaust opening position), rotate the motor to allow the 5mm AKA transfer port checking tool to be inserted into one of the main transfer ports. Bring the piston up to gently hold pressure on the tool at this point the second mark on the piston travel rod must not be visible above the head of the gauge, repeat the process on the opposing transfer port.

Step 6.

If the engine fails the field test it is to be sealed and sent to the state technical Officer for second and final verification of compliance using an analogue or digital indicator as in R26.04. 1.

Summary table of piston travel measurements in millimetres:

| Engine | Maximum stroke | TDC to exhaust opening | Exhaust open to inlet open | Exhaust open to transfer open (using rod with 5 grooves) | Exhaust open to transfer open (using rod with 4 grooves) |
|-------------------------|----------------|------------------------|----------------------------|--|--|
| Comer SW80 | 38.10 | 32.20 Max / 31.20Min | 21.40 min | 3.70 min | N/A |
| KT100J | 50.05 | 38.30 min | 26.80 min | 6.00 min | N/A |
| KT100S | 46.13 | 30.80 min | 14.80 min | 9.50 min | N/A |
| ARC Spec 100 | 46.13 | 30.80 min | 14.80 min | 9.80 min | N/A |
| Rotax Max 125 | 54.60 | 32.00 min / 33.8 max | N/A | N/A | 13.80 min |
| Formula JMA | 54.60 | 36.50 min / 37.50 max | N/A | N/A | 10.80 min |
| Parilla Leopard | 54.00 | 38.40 mm | N/A | N/A | 9.20 min |
| PRD Fireball | 54.00 | 38.30 min / 38.80 max | N/A | N/A | 9.60 min |
| ROTAX MAX c/n 223993 | 54.60 | 33.20min / 33.70 max | N/A | N/A | 15.00 min |
| ROTAX JMA c/n 223994 | 54.60 | 36.80 min / 37.30 max | N/A | N/A | 11.80 min |
| PARILLA X30 | 54.00 | 36.80 min / 37.00 max | N/A | N/A | 10.30 min |
| CHEETAH CNC | 54.00 | 38.20 min / 38.70 max | N/A | N/A | 9.80 min |

26.05 Final Engine Compliance check Conducted by a State Technical Officer

Engine to be measured in accordance with the respective homologation/registration documents held by the AKA.

All measuring to be performed using Analogue/Digital measuring equipment.

26.06 Procedure for use of AKA14 & AKA39 gauge

The AKA14 test rod (which can also be used for the AKA 39) has cut outs for ease of compliance checking. At all points of checking, the plane across the inlet pipe must fall within the cut outs on the rod for the respective measurement.

Step 1

Insert rod into the inlet of the muffler, pass through the 19mm outlet tube until the rod contacts end cap of baffle.

Nominal measurement 570mm for the AKA14 & 470 mm for the AKA 39. Dimension B

Step 2

Withdraw rod until lip locates on exhaust outlet tube (end of 19mm tube)

Nominal measurement 512mm. Dimension C

Step 3

Withdraw rod until lip locates on main deflector plate

Nominal measurement 422. Dimension D

Preamble:

The purpose of this Class is to teach young people to drive karts of restricted performance at limited cost. To be eligible to compete in this class, drivers must have a minimum of an AKA D Grade Licence endorsed as a MIDGET. This class has State Championship status.

27.01 Driver Limitations:

1. Age from their seventh (7) birthday until the end of the calendar year of their eleventh (11) birthday. (for drivers entering the sport)
2. The license applicant must produce a birth certificate to the State Secretary before a new licence is issued.
3. Options exist for advancement to Rookie Division. Refer rule 13.19.1

27.02 Engine Eligibility:

The only engines approved for use in this class are the;

1. COMER SW80 as per specifications available at karting.net.au
2. Yamaha KT100J, as per specifications available at karting.net.au. The specifications and tolerances are to be strictly adhered to, but with the INCLUSION of an AKA issued exhaust restrictor plate with a 13.02 mm maximum diameter hole and of 2.1 mm maximum thickness. Restrictor plate must be fitted between the cylinder and exhaust header pipe with a gasket on both sides of the restrictor plate and be located on both exhaust header studs. All exhaust gases must pass through the 13.02 mm max restrictor plate. The exhaust restrictor plates will be supplied by the AKA and identifiable as such - stamped "AKA1".

Maximum exhaust length restrictions apply. Refer to Yamaha KT100J engine specifications at www.karting.net.au

NO MODIFICATIONS ARE PERMITTED.

27.03 Weight:

As per rule 25.19 the minimum combined kart / driver weight to be;
90 kgs for Comer SW80 and 100 kgs for Yamaha KT100J

27.04 Tyres:

1. No modifications permitted, tyre treatment is illegal (refer rule 23.03)
2. Dry Weather Tyres Dunlop SL1A (1 set + 1 replacement tyre / meeting) Optional to use either 10 x 4.5 - 5 OR 11 x 7.1 - 5 tyres on the rear
3. Dunlop KT6SLW1 (1 set + 1 replacement tyre / meeting) Optional to use either 10 x 4.5 -5 OR 11 x 6.00 - 5 tyres on the rear

27.05 Midget facing Stewards

Any Midget called before a Steward/s or Official must be accompanied by a Parent/Guardian. Refer to rule 7.29

27.06 Restarting before a race

In the event of a spin or collision during the rolling laps, prior to the Start of a race, Midgets are permitted to be restarted with assistance by delegated persons and at the discretion of the Starter and/or Clerk of Course. Delegated persons must retire to a safe position once the race has commenced.

CHAPTER 28

ROOKIES

Preamble:

The purpose of this Class is to teach young people to drive karts of restricted performance at limited cost.

To be eligible to compete in this class, drivers must have a minimum of a D Grade Licence endorsed as a Rookie.

Rookies class has State Championship status.

28.01 Driver Limitations:

1. Aged from their ninth (9) birthday until the end of the calendar year of their twelfth (12) birthday.
2. The license applicant must produce a birth certificate to the State Secretary before a new licence is issued.
3. Options exist for advancement to Junior Division. Refer rule 13.19.2

28.02 Engine Eligibility:

The only engine approved for use in this class is the YAMAHA KT100J series engine as per specifications available at karting.net.au

The specifications and tolerances are to be strictly adhered to, but with the INCLUSION of an exhaust restrictor plate with a 16.00 mm maximum diameter hole and of 2.1 mm maximum thickness. Restrictor plate must be fitted between the cylinder and exhaust header pipe with a gasket on both sides of the restrictor plate and be located on both exhaust header studs. All exhaust gases must pass through the 16.00mm max restrictor plate. The exhaust restrictor plates will be supplied by the AKA and identifiable as such - marked "AKA2A".

Maximum exhaust length restrictions apply. Refer to Yamaha KT100J engine specifications at www.karting.net.au

NO MODIFICATIONS ARE PERMITTED.

28.03 Weight:

As per rule 25.19 the minimum combined kart / driver weight to be;

Rookies 105 kg

28.04 Tyres:

1. No modifications permitted, tyre treatment is illegal (refer rule 23.03)
2. Dry Weather Tyres Dunlop SL1A (1 set + 1 replacement tyre / meeting)
Optional to use either 10 x 4.5 – 5 OR 11 x 7.1 – 5 tyres on the rear
3. Wet Weather Tyres Dunlop KT6SLW1 (1 set + 1 replacement tyre / meeting)
Optional to use either 10 x 4.5 – 5 OR 11 x 6.00 – 5 tyres on the rear.

28.05 Rookie facing Stewards

Any Rookie called before a Steward/s or Official must be accompanied by a Parent/Guardian. Refer to rule 7.29.

28.06 Restarting before a race

In the event of a spin or collision during the rolling laps, prior to the Start of a race, Rookies are permitted to be restarted with assistance by delegated persons and at the discretion of the Starter and/or Clerk of Course. Delegated persons must retire to a safe position once the race has commenced.

CHAPTER 29

JUNIOR NATIONAL

Preamble:

Junior National is a low horsepower class using low grip tyres.

To be eligible to compete in the Junior National 100cc class, drivers must have a minimum of a D Grade Junior Licence. Junior National class has State and National Championship status in both Light and Heavy divisions.

29.01 DRIVER LIMITATIONS

1. Aged from their twelfth (12) birthday until the end of the calendar year of their sixteenth (16) birthday as per rule 13.04.3
2. Options exist for advancement to Junior Clubman, Junior Performance or Junior Rotax Max as per rule 13.19.3(d)
3. Options exist for advancement to Senior Division as per rule 13.19.3

29.02 Engine Eligibility:

The only engine approved for use in this class is the YAMAHA KT100J series engine as per specifications available at karting.net.au

29.03 Weight:

As per rule 25.19, the minimum combined kart / driver weight to be;

- | | | | |
|---------------------------|---|--------|--|
| (a) Junior National Light | - | 120kg. | |
| (b) Junior National Heavy | - | 140kg | maximum kart weight 88kg as per rule 25.19.2 |

29.04 Tyres

1. No modifications permitted, tyre treatment is illegal (refer rule 23.03)
2. Dry Weather Tyres Dunlop SL1A (1 set + 1 replacement tyre / meeting)
3. Wet Weather Tyres Dunlop KT6SLW1 (1 set + 1 replacement tyre / meeting)

29.05 Junior Facing Stewards:

Any Junior competitor called before a Steward/s or Official must be accompanied by a Parent/ Guardian. (Refer Rule 7.29).

CHAPTER 30

JUNIOR CLUBMAN

Preamble

Junior Clubman is a medium performance class for eligible Junior competitors to experience increased horsepower and medium grip tyres.

This class has State and National Championship status.

30.01 Driver Limitations:

Aged from their thirteenth (13) birthday until the end of the calendar year of their sixteenth (16) birthday with a minimum of a B grade Junior Licence that has been endorsed at six (6) race meetings in a Junior National Class, as per rule 13.19.3(d)

30.02 Engine Eligibility:

The following engines are approved for use in this class;

YAMAHA KT100S

ARC SPEC 100A

ARC SPEC 100W

HYBRID/Hybrid

ARC SPEC 100A – Air-Cooled/Hybrid

YAMAHA KT100SEC.

The relevant engine specifications and tolerances are available from the technical section of the AKA web site at www.karting.net.au.

Note: From 1st January, 2012, the only engines eligible for this class will be the Yamaha KT100S and the Yamaha KT100SEC.

30.03 Weight:

As per rule 25.19, the minimum combined kart / driver weight to be;

Aircooled engines 135kg,

Watercooled engines 140 kg

30.04 Tyres:

1. No modifications permitted, tyre treatment is illegal (refer rule 23.03)
2. Dry Weather Tyres MG AZ Red (1 set + 1 replacement tyre / meeting)
3. Wet Weather Tyres Dunlop KT6SLW1 (1 set + 1 replacement tyre / meeting)

30.05 Junior Facing Stewards:

Any Junior called before a Steward/s or Official must be accompanied by a Parent/Guardian.

30.06 Restarting Before Race:

In the event of a spin or collision during the rolling laps, or to the Start, Juniors are permitted to be restarted with assistance by delegated persons and at the discretion of the Starter and/or Clerk of Course. Delegated persons must retire to a safe position once the race has commenced. (Refer Rule 16.08).

30.07 Engine Fin Dampening:

It is COMPULSORY that a fin dampening system that effectively reduces noise be fitted to all air cooled engines in this class.

CHAPTER 31

FORMULA JUNIOR MAX

Preamble:

Formula Junior MAX is a medium performance class for eligible Junior competitors to experience increased horsepower and medium grip tyres.

This class has State and 'Stand Alone' National Championship status.

The promoters of this class reserve the right to alter the technical regulations with AKA approval at short notice to ensure the safety of drivers, fairness of competition, economy and wishes of the competitors.

31.01 Driver Limitations:

Aged from their thirteenth (13) birthday until the end of the calendar year of their sixteenth (16) birthday with a minimum of a B grade Junior Licence that has been endorsed at six (6) race meetings in a Junior National Class (rule 13.19.3(d))

31.02 Engine Eligibility:

The only engine eligible for the Formula JMA class is the BRP-Rotax Junior Max. For use in Australian racing, every engine must have the Official Formula Rotax Australia Stamp on the crankcase and also on the reed block face of the cylinder. For engine technical specifications, refer to www.karting.net.au

For sealing purposes, the engine is to be fitted with "fit for purpose" sealing nuts with minimum 3mm holes. The engine is sealed using a single AKA seal through appropriate sealing nuts fitted at three (3) locations;

1. The cylinder head water jacket
2. The upper gearbox case
3. The reed block.

31.03 Weight:

As per rule 25.19, the minimum combined kart / driver weight to be;

Formula JMA 145 kg with a maximum kart weight of 100kg as per rule 25.19.2

31.04 Tyres:

The only tyres allowed are:

Dry weather tyres: Mojo D2 (1 set + 1 replacement tyre / meeting)

Front: 4.5 x 10.0 – 5 Rear: 7.1 x 11.0 – 5

Wet weather tyres: Mojo W2 (1 set + 1 replacement tyre / meeting)

Front: 4.0 x 10.0 – 5 Rear: 6.5 x 11.0 – 5

31.05 Chassis:

Must comply to existing AKA formula with the following additional restrictions.

- 1 Frame - round tubing only or maximum of one main rail not round. Maximum diameter for frame tubing is 35.5mm, (inclusive of paint).
- 2 Composite Materials are banned, except for the seat, Nassau panel and floor tray.
- 3 Maximum Axle diameter of 50.0mm.

31.06 Junior Facing Stewards:

Any Junior competitor called before a Steward/s or Official must be accompanied by a Parent/ Guardian.

31.07 Restarting Before Race:

In the event of a spin or collision during the rolling laps, prior to the Start, Juniors are permitted to be restarted with assistance by delegated persons and at the discretion of the Starter and/or Clerk of Course.

Delegated persons must retire to a safe position once the race has commenced.

CHAPTER 32

JUNIOR PERFORMANCE

Preamble:

Junior Performance Class is a restricted higher performance based Junior Class using medium grip tyres.

This class is NOT eligible for State or National Championships, is NOT eligible to be conducted at State or National Championships as a support class, but may be conducted as a State based only series.

32.01 Driver Limitations:

To be eligible to compete in the Junior Performance class, drivers must be a minimum of 13 years of age and have a minimum of a B Grade Junior Licence that has been endorsed at six race meetings in a Junior National Class.

32.02 Engine Eligibility and Restrictor Plate Sizing:

The following engines are approved for use in this class with the relevant AKA exhaust restrictor plate. The restrictor plate must be as supplied by the AKA, must be fitted between the cylinder and exhaust header pipe or flange with a gasket on both sides of the restrictor plate and be located on all exhaust header studs or bolts. All exhaust gases must pass through the restrictor plate opening. It is compulsory that sealable nuts/bolt to be fitted on exhaust studs for restrictor plate sealing, minimum hole size 2mm.

- Yamaha KT 100s (no restrictor plate required)
- Yamaha KT-SEC (no restrictor plate required)
- ARC Spec 100A (no restrictor plate required)
- ARC Spec 100W (no restrictor plate required)
- PRD Fireball 125 with "AKA F1" exhaust restrictor with max 24.50mm hole.
- Parilla Leopard 125 with "AKA L2" exhaust restrictor with max 23.80mm hole.
- lame X30 125 with "AKAX30" exhaust restrictor with max 23.40mm hole.
- SQ Cheetah 125 with "AKA SQ1" exhaust restrictor with max 25.00mm hole.
- Rotax Max 125 with "AKA SR2" exhaust restrictor with max 24.50mm hole.
- Rotax Junior Max 125 with "AKA JR1" exhaust restrictor with max 26.00mm hole.

The relevant engine specifications and tolerances are available from the technical section of the AKA web site at karting.net.au.

32.03 Weights: As per rule 25.19, the minimum combined kart / driver weight to be;

| | |
|---------------------|---------------|
| 100 cc Air-cooled | 135Kg Minimum |
| 100 cc Water-cooled | 140Kg Minimum |
| 125 cc Water-cooled | 145Kg Minimum |

These minimum weights to be continually reviewed at each NKC meeting throughout the year to achieve parity.

32.04 Tyres:

No modifications permitted, tyre treatment is illegal (refer rule 23.03).

Dry Weather Tyres - MG AZ Red - (1 set + 1 replacement tyre / meeting).

Wet Weather Tyres - Dunlop KT6SLW1 - (1 set + 1 replacement tyre / meeting).

32.05 Junior Facing Stewards:

Any Junior called before a Steward/s or Official must be accompanied by a Parent/Guardian.

32.06 Restarting Before Race:

In the event of a spin or collision during the rolling laps, or to the Start, Juniors are permitted to be restarted with assistance by delegated persons and at the discretion of the Starter and/ or Clerk of Course. Delegated persons must retire to a safe position once the race has commenced.

CHAPTER 33

SENIOR NATIONAL 100cc

Preamble

Senior National 100cc is a low horsepower class using low grip tyres.
This class has State and National Championship status in both Light and Heavy divisions

33.01 Driver Limitations:

To be eligible to compete in the Senior National 100cc class, drivers must have a minimum of a D Grade Senior Licence.

33.02 Engine Eligibility:

The only engine approved for use in this class is the:
YAMAHA KT100J series engine.

The relevant engine specifications and tolerances are available from the technical section of the AKA web site at karting.net.au.

33.03 Weight:

As per rule 25.19 the minimum combined kart / drive weight to be;

- | | |
|---------------------------------|--|
| (a) Senior National 100cc Light | 140kg |
| (b) Senior National 100cc Heavy | 155kg maximum kart weight 88kg as per rule 25.19.2 |

33.04 Tyres

1. No modifications permitted, tyre treatment is illegal (refer rule 23.03)
2. Dry Weather Tyres Dunlop SL1A (1 set + 1 replacement tyre / meeting)
3. Wet Weather Tyres Dunlop KT6SLW1 (1 set + 1 replacement tyres / meeting)

CHAPTER 34

CLUBMAN 100cc

Preamble:

Clubman 100cc class is a medium horse power class using medium grip tyres.

This class has State and National Championship status in Light, Heavy and Super Heavy divisions and State Championship status in Over 40's division.

34.01 Driver Limitations:

To be eligible to compete in the Senior Clubman 100cc class, drivers must have a minimum of a D Grade Senior Licence.

34.02 Engine Eligibility:

The following engines are approved for use in this class;

YAMAHA KT100SE

YAMAHA KT100SD

YAMAHA KT100SEC (electric start with clutch)

NOTE. There can be NO interchange of all major components between the KT100SEC engine and the KT100SE & KT100SD engines. The major components are as follows:

- Crankshaft halves are subject to moratorium until 1 Jan 2009
- Cylinder
- Crankcases
- Ignition rotor
- Ignition stator
- Ignition stator carrier plate

The KT100SEC must run with a clutch and a complete KT100SEC engine starting system.

The relevant engine specifications and tolerances are available from the technical section of the AKA web site at www.karting.net.au

34.03 Weights:

As per rule 25.19 the minimum combined kart / driver weight to be;

- | | |
|---------------------------|---|
| (a) Clubman Light | 140 kg |
| (b) Clubman Heavy | 160 kg maximum kart weight 88kg as per rule 25.19.2 |
| (c) Clubman Super Heavy | 180 kg maximum kart weight 88kg as per rule 25.19.2 |
| (d) Clubman Over 40 (yrs) | 160 kg |

34.04 Tyres:

1. No modifications permitted, and tyre treatment is illegal. (refer rule 23.03)
2. Dry weather tyres MG AZ Red (1 set + 1 replacement tyre / meeting)
3. Wet weather tyres Dunlop KT6SLW1 (1 set + 1 replacement tyre / meeting)

CHAPTER 35

YAMAHA 100 TAG CLASS

Preamble:

This class will be out of the box racing, no modifications are allowed to the engine unless specifically stated. The spirit and intent of this class is to provide a class to be used as a stepping-stone in the sport without the pressures of championship racing beyond club and zone level. The motor selected is in the modern idiom of electric start with a centrifugal clutch for ease of operations with limitations and controls. The motor has low wear factor and is designed for long prolonged low maintenance use, ideal for club use and for the club driver who just wants to race at his local area over long periods.

35.01 Driver Limitations:

To be eligible to compete in this class a competitor must hold:

- (1) A minimum D grade Senior Licence
- (2) Maximum C grade Senior licence
- (3) Drivers over 40 years of age who hold a B grade licence are excluded from this limitation

35.02 Engine Eligibility:

The only engine approved for use in this class is:

Yamaha Model KT100SEC 100cc (pre-fix 7YK) Electric Start only.

The relevant engine specifications and tolerances are available from the technical section of the AKA web site at www.karting.net.au

35.03 Weight

As per rule 25.19, the minimum combined kart / driver weight to be;
Yamaha 100 Tag - 160kg

35.04 Tyres

1. No modifications permitted, tyre treatment is illegal (refer rule 23.03)
2. Dry Weather Tyres Dunlop SL1A (1 set + 1 replacement tyre / meeting)
3. Wet Weather Tyres Dunlop KT6SLW1 (1 set + 1 replacement tyre / meeting)

35.05 Wheels /Rims

Front Rims: Edward Spoke F117S-5FUT only

Rear Rims: Edward Spoke R200-5FUT only

Wet Rims free when wet tyres are used

35.06 Wheel Hubs:

Alloy hubs only - magnesium hubs are not permitted.

35.07 Axle:

40mm axle only permitted. Refer Chapter 25.01 (e) of the current manual

35.08 Gauges:

Tacho and timing gauges allowed only. No temperature probes or sensors on head or exhaust.

35.09

These rules may be altered or adjusted as directed by the AKA at short notice.

CHAPTER 36

SPORTSMAN CLASS

Preamble:

The Sportsman Class was approved to allow Clubs / States to form classes appropriate to their requirements. All classes formed must have a written class specification, be approved by the relevant State Karting Council and conducted in accordance with rule 19.37.

This class is NOT eligible for State or National Championships, is NOT eligible to be conducted at State or National Championships as a support class, but may be conducted as a State based only series. The following specifications have been provided by the AKA for the conduct of this class.

36.01 Driver Limitations:

To be eligible to compete in this class, a competitor must hold a minimum of a D Grade licence unless otherwise stated.

36.02 Engine Eligibility:

As per State Karting Council recommendations.

36.03 Weights:

As per rule 25.19, the minimum combined kart / driver weight to be;
As per State Karting Council recommendations.

36.04 Tyres

1. Dry weather tyres As per State Karting Council recommendations
2. Wet weather tyres Dunlop KT6SLW1 (1set + 1 replacement tyre / meeting)

CHAPTER 37

RESTRICTED 125 CLASS

Preamble:

This class was introduced to allow less experienced drivers to race electric start, water cooled engine karts at restricted performance.

This class is NOT eligible for State or National Championships, is NOT eligible to be conducted at State or National Championships as a support class, but may be conducted as a State based only series.

37.01 Driver Limitations:

To be eligible to compete in this class a driver must hold a minimum D Grade "provisional" or C Grade licence.

'A' and 'B' Grade licence holder are not eligible to compete in this class.

A & B Grade licence holders may elect to be downgraded to a C grade licence at anytime to participate in this class as per rule 13.17.5.

37.02 Engine Eligibility and Restrictor Plate Sizing:

The following engines are approved for use in this class with the relevant AKA exhaust restrictor plate. Restrictor plates are compulsory and as determined by the AKA and subject to any future parity adjustments. The restrictor plate must be as supplied by the AKA, must be fitted between the cylinder and exhaust header pipe or flange with a gasket on both sides of the restrictor plate and be located on all exhaust header studs or bolts. **Restrictor plates to have a maximum allowable thickness of 2.1 mm.**

All exhaust gases must pass through the restrictor plate opening. It is compulsory that sealable nuts/bolt to be fitted on exhaust studs for restrictor plate sealing, minimum hole size 2mm.

1. PRD Fireball 125 with "AKA F1" exhaust restrictor with max 24.50mm hole.
2. Parilla Leopard RL125 with "AKA L2" exhaust restrictor with max 23.80mm hole.
Parilla Leopard ignition module marked AKA20L is not compulsory.
3. Rotax Max 125 with "AKA SR2" exhaust restrictor with max 24.50mm hole.
4. Rotax Junior Max 125 with "AKA JR1" exhaust restrictor with max 26.00mm hole.
5. SQ Cheetah 125 with "AKA SQ1" exhaust restrictor with max 25.00mm hole.
6. Parilla Leopard X30 125 with "AKAX30" exhaust restrictor with max 23.40mm hole.

Note:

- Parilla Leopard RL 125 – The Selettra 4 pole and Selettra digital K ignition systems must use the exhaust restrictor marked AKAL1 with a max 23.00mm hole.
- Parilla Leopard RL 125 – with the Selattra digital K ignition module AKA20L must use the exhaust restrictor marked AKAL2 with a max 23.80mm hole.

The relevant engine specifications and tolerances are available from the technical section of the AKA web site at www.karting.net.au.

37.03 Weights:

As per rule 25.19, the minimum combined kart / driver weight to be;

Restricted 125 Light 160Kg Minimum

Restricted 125 Heavy 180Kg Minimum (Maximum Kart weight 100kg) as per rule 25.49.2

37.04 Tyres:

1. No modifications permitted, tyre treatment is illegal (refer rule 23.03)
2. Dry Weather Tyres MG AZ Red (1 set + 1 replacement tyre / meeting)
3. Wet Weather Tyres Dunlop KT6SLW1 (1 set + 1 replacement tyre / meeting)

CHAPTER 38

FORMULA ROTAX 125

Preamble:

Formula Rotax 125 is a high performance class for eligible Senior competitors to experience increased horsepower with medium grip tyres.

This class has State and 'Stand Alone' National Championship status.

The promoters of this class reserve the right to alter the technical regulations with AKA approval at short notice to ensure the safety of drivers, fairness of competition, economy and wishes of the competitors.

38.01 Driver Limitations:

To be eligible to compete in the Formula Rotax 125 class, drivers must have a minimum of a non-restricted B Grade Senior Licence.

38.02 Engine:

1. The only engine eligible for the Formula Rotax 125 class is the BRP-Rotax FR125 Max. For use in Australian racing, every engine must have the Official Formula Rotax Australia Stamp on the crankcase and also on the reed block face of the cylinder. For engine technical specifications, refer to www.karting.net.au
2. For sealing purposes, the engine is to be fitted with "fit for purpose" sealing nuts with minimum 3mm holes. The engine is sealed using a single AKA seal through appropriate sealing nuts fitted at three (3) locations;
 1. The cylinder head water jacket
 2. The upper gearbox case
 3. The reed block.

38.03 Weight:

As per rule 25.19, the minimum combined kart / driver weight to be;

Formula Rotax 125 Light 160 kg

Formula Rotax 125 Heavy 180 kg - maximum kart weight of 100kg as per rule 25.19.2

38.04 Tyres:

The only tyres allowed are:

Dry weather tyres: Mojo D2 (1 set + 1 replacement tyre / meeting)

Front: 4.5 x 10.0 – 5 Rear: 7.1 x 11.0 – 5

Wet weather tyres: Mojo W2 (1 set + 1 replacement tyre / meeting)

Front: 4.0 x 10.0 – 5 Rear: 6.5 x 11.0 – 5

38.05 Chassis:

Must comply to existing AKA formula with the following additional restrictions.

1. Frame - round tubing only or maximum of one main rail not round. Maximum diameter for frame tubing is 35.5mm, (inclusive of paint).
2. Composite Materials are banned, except for the seat, Nassau panel and floor tray.
3. Maximum Axle diameter of 50.0mm

CHAPTER 39

PARILLA LEOPARD 125cc

Preamble:

Parilla Leopard 125 is a high performance class for eligible Senior competitors to experience increased horsepower with high grip tyres.

This class is eligible for State and National Championships.

The promoter of this class reserves the right to alter the technical regulations with AKA approval at short notice to ensure the safety of drivers, fairness of competition, economy and the wishes of the competitors.

39.01 Driver Limitations:

To be eligible to compete in this class a competitor must hold a minimum non-restricted AKA B Grade Senior Licence.

39.02 Engine Eligibility:

1. Parilla Leopard RL 125cc and Parilla Leopard X 30 engines only.
2. The engine must be manufactured by IAME and Australian delivered and imported by Remo Racing Pty Ltd to be eligible for competition.
Remo Racing Pty Ltd has all engine numbers recorded.
3. Technical specifications are available from www.karting.net.au

39.03 Weight:

As per rule 25.19, the minimum combined kart / driver weight to be;

| | | |
|-------------------|-------|--|
| Leopard 125 Light | 160kg | |
| Leopard 125 Heavy | 180kg | Maximum kart weight 100 kg as per rule 25.19.2 |

39.04 Tyres:

1. No modification permitted, tyre treatment is illegal (refer rule 23.03)
2. Dry weather tyre MG FZ Yellow (1 set + 1 replacement tyre / meeting)
3. Wet weather tyre MG WZ wet only. (1 set + 1 replacement tyre / meeting)

39.05 Chassis:

1. The chassis is to conform to the Australian Kart Formula as detailed in chapter 25 of the AKA Karting Manual.

CHAPTER 40

TAG 125

Preamble:

This class provides Australian Karting with a category that allows competitors with a variety of engines to compete with each other on even terms.

The promoters of this class reserve the right to alter the technical regulations with AKA approval at short notice to ensure the safety of drivers and the fairness of competition.

It is expected that this class will be the entry point for future TAG 125cc engines excluding the future SUPER engines.

40.01 Driver Limitations:

To be eligible to compete in the Tag 125 class, drivers must have a minimum of a non-restricted B Grade Senior Licence.

40.02 Engine Eligibility:

A variety of TAG (Touch and Go) style engines are eligible for use in this category. Engines can be added or removed at any time by the class promoter.

All engines and their respective ancillaries must conform to their individual class regulations. Engines without an individual class must conform to the technical specifications of the engine, available at www.karting.net.au

Current eligible engines are:-

1. PRD Fireball 125cc
2. Rotax Max 125cc
3. Parilla Leopard 125cc
4. SQ Cheetah 125
5. Parilla Leopard X30 125cc.

40.03 Weights:

| WEIGHTS | LIGHT CLASSES | HEAVY CLASSES |
|--------------------------|---------------|---------------|
| Rotax: | 165kg | 185kg |
| Leopard: | 160kg | 180kg |
| Fireball: | 160kg | 180kg |
| SQ Cheetah: | 160kg | 180kg |
| Parilla Leopard X30 125: | 165kg | 185kg |

40.04 Tyres:

Dry Weather Tyres: MG AZ Red for all engine types
Wet Weather Tyres: MG WZ White for all engine classes.

40.05 Chassis

The kart is to conform to the general kart formula as detailed in chapter 25 of the AKA Karting Manual.

CHAPTER 41

FORMULA 100

Preamble

This class exists as an intermediate step for those senior karters wishing to compete in the CIK classes at national championships level and for karters being too heavy for the CIK weights. It is intended that the costs of competition in this class should be controlled however the technical requirements for engines will be the same as the CIK classes to allow easy exchange of equipment and easy transition through classes.

41.01 Driver Limitations:

1. To be eligible to compete in this class, a competitor must hold a minimum of an un-restricted A or B Grade AKA licence.
2. Drivers entering this class from junior classes must complete a minimum of three (3) meetings displaying P plates, to be removed through an endorsement to the licence, on the satisfaction of the stewards.

41.02 Engines

1. Any homologated single cylinder series production air or water cooled engine complying to CIK Formula A or Intercontinental A regulations is eligible. Maximum exhaust port timing for Intercontinental A engines does not apply for this class.
2. It must be possible to identify an homologated engine or its parts (cylinder head, cylinder, crank cases and crank shaft) by the technical descriptions (photos, technical drawings and the like) on the homologation forms.
3. Maximum capacity 101cc, except for pre 1998 engines which may be maximum 103cc.
4. All systems of powervalve are forbidden
5. In addition to any currently approved engines for the Formula 100 Class, newly homologated CIK engines will become eligible in the year in which they are homologated by CIK and following registration with the AKA.
6. Unless otherwise specified all parts are to be by the original engine manufacturer.

41.03 Exhaust Port Height Check for pre 1998 homologated engines:

| Stroke | Rod Length centre distance | Piston allowable travel |
|--------|-------------------------------|----------------------------|
| 52.0 | 100 | 30.1 |
| 51.0 | 100 | 29.5 |
| 50.6 | 100 | 29.2 |
| 50.5 | 100 | 29.1 |
| 50.0 | 100 | 28.8 |
| 48.5 | 98 | 27.9 |
| 46.0 | 96 | 26.4 |

41.04 Modifications:

1. Modifications to homologated engines are permitted, EXCEPT to the following:
 - Stroke
 - Bore (outside maximum limits)
 - Number of transfer passages and inlet ports in the cylinder and crankcase.
 - Number of exhaust ports and passages.
(the creation of new exhaust ports or passages is forbidden.)
 - Connecting Rod centre distance. (magnetic material compulsory)
2. It must always be possible to identify the original parts of the homologated engine.

41.05 Ignition:

Only group 2 CIK homologated ignition system is permitted

41.06 Non Tech Items:

Unless otherwise specified, non tech items include – bearings and cages, crank pin, fasteners, gaskets, piston and rings, seals, piston pin, spacers, washers, spark plug. (refer Rule 25.21)

41.07 Exhaust System:

For reed valve engines (Intercontinental A) in this class it is not compulsory to use the CIK homologated exhaust pipe.

41.08 Carburettor:

1. Carburettor to be Formula A type:
A = 24.0mm OR A = 25.5mm
B = 27.8mm B = 25.5mm

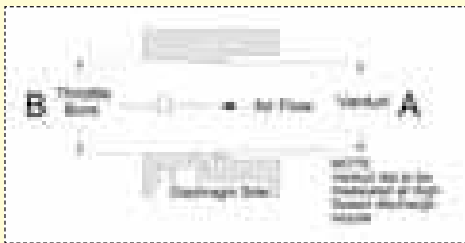

DIAGRAM IS FOR DIMENSIONAL REFERENCE ONLY

2. Carburettor may be either two or three jet – 25.4mm or 27mm.
3. All systems of injection and/or spraying of products other than fuel are forbidden.

41.09 Weight:

As per rule 25.19 the minimum combined kart / driver weight to be;

| | |
|-------------------|--|
| Formula 100 Light | 150 kg |
| Formula 100 Heavy | 170kg (88kg maximum kart weight.) as per rule 25.19.2 |

41.10 Tyres:

1. No modifications permitted, tyre treatment is illegal. (refer rule 23.03).
2. **Dry weather tyres** MG Yellow (1 set + 1 replacement tyre / meeting).
3. **Wet weather tyres** Any CIK group 2 wet – chapter 23.
(1 set + one 1 replacement tyre / meeting).

CHAPTER 42

OPEN PERFORMANCE CLASS

Preamble:

This class is a high performance class for eligible senior competitors, to allow any homologated and AKA registered engines to be run together, using high grip tyres. This class is not eligible for National Championships but can be run at State Championships with approval from the N.K.C.

42.01 Driver Limitations:

To be eligible to compete in this class, a driver must hold a minimum of an AKA B Grade licence.

42.02 Engine Eligibility:

1. Must be series Production Engine
2. Must be AKA OR CIK – Homologated and/or Registered.
3. Two stroke or Four Stroke engines.
4. Single or Twin Engines.
5. Engines may be air or water-cooled.
6. Clutches and electric starters are permissible.
7. Reverse gear is forbidden.
8. Further restrictions on engines eligible for specific events may be specified in the events supplementary regulations.

42.03 Maximum Engine Capacity:

1. Two Stroke engines – 206cc total cylinder volume.
2. Two stroke engines – 255 cc total cylinder volume where twin 125 cc TAG style, AKA registered engines of the same type (brand & model) are used together. In this case, the following requirements must be observed:
 - Engines including all auxiliaries (with the exception of batteries, exhaust and external cooling system), must conform to appropriate engine class chapter.
 - Exhaust system must be based on original engine system, but may be modified to provide installation or packaging requirements. Typically, parts of the exhaust may be cut and swivelled, but the overall length must remain the same as the original, with a +/- 2 mm difference allowed per each individual cut. Concave denting to allow closer mating of the muffler/silencer bodies is permitted.
 - The cooling system of the original basic engine must be maintained, however the type of radiator (single or combined), pump (single or twin) and all hosing, connections, etc is free.
 - Engine batteries are free, but must conform to Rule 25.27
 - Any type of air induction silencer can be used on any engine, as long as it has conforms to a past or present AKA rulebook and that it has 2 off air inlet tubes of $\varnothing 23$ max and 94.50 minimum length through which all the engine intake air must pass through. Air box adapter must be as per engine class chapter.
3. Four Stroke engines – 250cc total cylinder volume.

42.04 Weights:

Refer to the event supplementary regulations for class weights.
Different weights may be specified to equalize different engines within the one event.

42.05 Tyres:

1. The tyres to be used will be specified in the event supplementary regulations.
2. No modifications permitted, tyre treatment is illegal (refer rule 23.03).
3. Dry Weather Tyres – any AKA approved 5" slick – 1 x set plus 1 replacement tyre per meeting.
4. Wet Weather Tyres – any AKA approved wet – 1 x set plus 1 replacement tyre per meeting.
Bead retention optional, but compulsory on all karts with a combined kart & driver weight of above 170 kg

42.06 Carburettor:

One single throat carburettor per cylinder.

42.07 Ignition System:

Digital ignition systems are allowed if fitted to the engine originally by the manufacturer and are of the same type and style as originally fitted, otherwise only analogue type ignition systems are permitted.

42.08 Braking:

Front wheel brakes may be used and are compulsory on all karts with a combined (kart & driver) weight of above 170 kg.

- 43.1** The Chapter is in 2 parts, firstly, the introduction and class specific regulations and secondly, the Championship Rules.
In this Chapter, 'organiser', 'organisers', 'organising body' and 'promoter' mean the AKA unless the NKC on recommendation of the IKC approve otherwise.
- 43.2 Preamble:**
CIK Classes for Australia shall consist of KF1, KF3 and KZ2.
These classes will be raced in Australia to provide the necessary experience for Australian drivers and manufacturers to compete competitively in CIK International events. To this end, the CIK classes will be raced as close to CIK/FIA International Technical and Race Regulations that local conditions will permit. The NKC may from time to time publish any alterations to the Championship Regulations or Chapter 43, as may be required. The Championship Regulations in this chapter do not apply to any competition other than CIK classes at rounds of their Australian Championships.
- 43.3 CIK Classes in Australia:**
The following CIK classes shall be raced in Australia: KF1, KF3 and KZ2.
The class will be conducted in accordance with the CIK/FIA Technical Regulations, unless otherwise stated in this Chapter.
- 43.4 Tyres:**
The tyres used by classes in Australia shall be described in:
Technical documents: TDKF1, TDKF3 and TDKZ2 these documents are available from the AKA website.
- 43.5 Wheels:** as per CIK Technical regulations 2.22.1 – Rims
Technical requirements shall be contained in:
Technical documents: TDKF1, TDKF3 and TDKZ2 these documents are available from the AKA website.
- 43.6 Homologated Engines and Modifications:**
Technical requirements shall be contained in:
Technical documents: TDKF1, TDKF3 and TDKZ2 these documents are available from the AKA website.
- 43.7 Weights:**
Technical requirements shall be contained in:
Technical documents: TDKF1, TDKF3 and TDKZ2 these documents are available from the AKA website.
- 43.8 Chassis:**
Technical requirements shall be contained in:
Technical documents: TDKF1, TDKF3 and TDKZ2 these documents are available from the AKA website.

43.9 Brakes:

Technical requirements shall be contained in:

Technical documents: TDKF1, TDKF3 and TDKZ2 these documents are available from the AKA website.

43.10 Radiator

Technical requirements shall be contained in:

Technical documents: TDKF1, TDKF3 and TDKZ2 these documents are available from the AKA website.

43.11 Air Box

Technical requirements shall be contained in:

Technical documents: TDKF1, TDKF3 and TDKZ2 these documents are available from the AKA website.

43.12 Battery: As per R25.27

43.13 Non-tech items and legal additions: As per Chapter 25.21

43.14 Noise: As per Chapter 24. Permitted noise level is 100db.

43.15 Other:

For clarification of any technical references in Chapter 43, refer to the CIK/FIA Technical Regulations in the current CIK/FIA Karting Yearbook or available on <http://www.auscikchampionship.com/> or the CIK/FIA website.

43.16 Technical documents: TDKF1, TDKF3 and TDKZ2 shall form part of these rules.

It is the competitor responsibility to obtain and be familiar with these documents.

43.17 Stand alone events and series other than National Championships and or State Championships conducted by the IKC\AKA.

- a) KF1, KF3 and KZ2 (gearbox) can be run independently to the CIK events but in doing so must strictly conform to the technical specifications contained within chapter 50 in all aspects unless authorized by the IKC and AKA.
- b) All club \ promoter events shall be authorized by the relevant SKC in conjunction with the IKC Championship Regulations

Championship Regulations

Australian Championships for CIK Classes

Article – 1

The Australian Karting Association will organise an Australian Championship for drivers in the various CIK Classes. These rules are formulated for the CIK classes to compete within a National championship under rules similar to International competition. Rules specific to the championships for the CIK classes are contained in these Championship Regulations. Where the Championship rules are in conflict, or otherwise, with the National Competition Rules the Championship rule shall take precedence over any similar rule found in the National Competition Rules. These rules may be modified, from time to time, by the National Karting Council on recommendation of the International Karting Committee.

The Championship is being conducted with the following objectives:

- [a] To conduct a National championship series that provides competitors with experience for international competition in the CIK classes.

- [b] To be a vehicle to promote the CIK classes, and international karting competition, on a National basis.
- [c] The Championship should be viewed as the pre-eminent karting competition within Australia second only to the CIK/FIA Oceania Championships.
- [d] The conduct of the Championship events within the race meetings should be the benchmark for quality in karting administration, promotion and operation of race meetings. In achieving this it is hoped to improve the experience, attitude and standard of karting officials on a national basis.
- [e] The Championships should be commercially attractive to sponsors.

Article 2 – Events

The Championship will be contested over **five** rounds in each of the states of Queensland, Victoria, **South Australia** and New South Wales. The classification of the Australian Championship will be established through the results obtained by the Drivers in all rounds of the Australian Championships. All rounds will be open to authorised drivers holding the appropriate International or National Licence. (See Article 9).

Round venues shall be published on the AKA website.

Article 3 – Organisation

The events will be conducted under the International Sporting Code of the FIA, the National Competition Rules of The Australian Karting Association, these Championship Regulations for the Australian Championships for the CIK Classes and such supplementary regulations, further addendum's and bulletins as may be issued by, or in conjunction with, the organising body of each race meeting.

The organisers reserve the right to issue Supplementary Regulations and/or instructions to entrants and/or drivers and these shall be of the same effect as these regulations.

Article 4

All the concerned parties: officials, promoters, entrants and drivers may only participate in the Australian Championships for CIK Classes on the condition that they respect all texts and documents which govern it.

Article 5

The right to associate the name of a commercial company, organiser or brand with the Australian Championship for CIK Classes is exclusively reserved for the series organiser, the Australian Karting Association.

Article 6 – Additional Classes

The IKC is the promoter of the Championship series and of each round of the series **and shall determine the additional classes to compete.**

Article 7 – Registration

Entry in the Championships point score will be by registration only. All entrants at all rounds are required to register. The Championship encourages drivers to compete in all rounds, however registration after the first round will be accepted. Championship points are allocated to individual drivers and are not transferable between drivers. Registration for the Championships will open on the 1st January. When registering, competitors will nominate a preferred race number (one or two digits only), which they shall retain for all rounds of the Championship. Numbers 1, 2 and 3 will be reserved for distribution by the AKA / IKC.

Article 8 – Fees

There is no fee to register for the championship. Competitors will pay an entry fee per round.

Article 9 – Eligible Competitors

The championship events are restricted to drivers holding, at the time of competition, the appropriate licence for that class and the endorsement of a licensed team.

International B grade licence or AKA A grade licence or AKA A grade Provisional via R13.18.3 or New Zealand A grade.

Article 10 – Entries

Details shall be made available via the supplementary regulations for each round of the championship.

Article 11 – Circuits and Practice

No practice is allowed on the Monday to Friday (inclusive) prior to each event unless it forms part of the meeting as notified in the sup regs. The track will be closed to karts after last race on Saturday. The only variance to these times will be stated in the Supplementary Regulations if so required.

Article 12 – Parc Ferme

The area of Parc Ferme includes, but is not limited to, the in and out grids, the weigh scales, the mechanical breakdown lane, the full track area with the safety fence and such other areas nominated in the supplementary regulations or notified by addendum or bulletin. Only persons with correct passes may enter parc ferme as per the official timetable. Only the driver and one designated approved mechanic per entry may enter parc ferme. Controls are in place as to the nature of equipment and materials that may be brought into parc ferme. These controls are communicated by the event regulations and will be interpreted and enforced by the responsible parc ferme officials.

Article 13 – Scrutineering

Administrative checking and scrutineering will take place as nominated in the supplementary regulations. All karts must be presented at scrutineering before participating in official practice. All engines must be entered on the technical passport prior to timed practice. At Technical passport inspection, each driver must present the equipment listed on the technical passport issued and it will be checked, marked and sealed in such a way as to be identifiable at any moment during the race. The entrant is required to have completed the Technical Passport. Race numbers and sponsors stickers are required to be in place for the competition. The placement of official sponsor's stickers on the bodywork of competing karts is compulsory when so advised.

Article 14 – Driver's Briefing

Driver's briefing will take place at a location and time to be nominated in the additional supplementary regulations or as announced on the events public address prior to the meeting. It is compulsory for the driver to attend all drivers briefings. Drivers who fail to attend a briefing or sign the attendance sheet will be referred to the stewards for penalty.

Article 15 – Telemetry and Data Logging

The use and/or fitting of telemetric equipment is prohibited during official practice and racing.

The use of data logging equipment is permitted during official practice and racing.

The AKA may require the fitment of technical equipment for the purpose of data logging to ensure the conformity of the clutch.

Article 16 – Medical

As per R3.26.

Article 17 – Championship Officials

Series Officials: Series Chief Steward, Series Clerk of Course, Series Co-ordinator and Chief Scrutineer/ Technical Officer.

Judges of Fact

The judges of fact at each round are the starter, chief scrutineer, weigh marshal, chief lap scorer, grid marshal, noise marshal and chief timing officer. The grid marshal shall be the judge of fact from the time of calling the entrants to the out grid until all of the competitors are under their own power on the track. All karts are under starting orders from the moment they leave the grid gate to the start of the race. The Starter shall be the judge of fact while under the starting orders and the Starter will determine competitors who break the start order, impede, delay or unduly affect the start procedure. The Chief Lap scorer shall be the judge of fact as to the number of laps completed and the finishing order of any event. The Weigh Marshal shall be the judge of fact as to the measured weight of any kart and driver at the completion of any event. The Scrutineer/Technical Officer shall be the judge of fact as to the technical compliance of any kart. The noise marshal's duties are set out in rule 24. The starter shall also be the noise marshal.

Article 18 – Fuel and Lubricants

The CIK classes will not use a control fuel for the Championships. Fuel regulations will be listed in the regulations for each round.

Article 19 – Equipment

Karts (chassis) must comply with either the current Australian Karting Association Technical Regulations or the current CIK/FIA International Karting Regulations and be either CIK homologated or AKA Registered approved and/or homologated, excluding the following rules from Article 2 of the International Regulations;

Rule 19 – Noise

Rule 26 – Timing Equipment

Rule 21 – Fuel

Rule 24 – Racing Numbers

(Note: Compliance with the CIK/FIA IKR will require the use of homologated equipment and components where referenced.)

The name of the driver shall appear in a visible position on the outside of the bodywork. In the interest of promotion of CIK competition and the sport, entrants must present themselves and their equipment in a clean, maintained and professional manner at all times.

Number plates will be black numbers on yellow background for seniors and white with black numbers for juniors, except for the current National Champions who may use the green plate with yellow numbers.

Article 20 – Changing of Equipment

Notice of any change of equipment must be notified to the Technical Officer /scrutineer before the start of any race or timed practice. Equipment, as entered on the technical passport, may be used at the entrant's discretion with the approval of the Technical Officer/ scrutineer. The change of chassis, engine or tyres is forbidden during the starting procedure and between the start and finish of any race unless the race is stopped and then declared a wet race.

Article 21 – Tyres

All tyres will be marked or be barcoded. Technical requirements shall be contained in Technical documents; TDKF1, TDKF3 and TDKZ2.

These documents are available from the AKA website at www.karting.net.au

Article 22 – Tyre Pooling

Tyre pooling and impounding may be employed and will be notified in the supplementary regulations.

Article 23 – Timed Qualifying Practice

Timed qualifying will be conducted using the AMB, or other CIK/FIA Group approved timing system. Transponder units must be fitted in purpose made AMB holders unless otherwise approved. The fastest lap time for each driver will determine their position on the grid for the heats. In the event of a tie, the fastest lap/laps will determine position. If no time is recorded for a driver they shall take the start in the heats at the rear of the grid. If several drivers are in that situation their starting positions shall be decided by drawing lots. Any driver who does not record a time is not eligible for a re-run unless in the opinion of the Stewards, the transponder was faulty. A competitor who fails to register a qualifying time as result of a faulty transponder or through the fault of the organisers, must be given a complete timed session. If it was the first or only qualifying session, the competitor may fit new tyres at his/her own expense and with the approval of the Stewards. When a transponder system is in use at race meetings for qualifying and/or lap scoring, it is the drivers responsibility to obtain their allocated transponder, correctly fit it to the kart and return it to the organisers. If a competitor is deemed to be underweight in a session they shall receive a time penalty of the slowest qualifying time for their class plus one second.

Article 24 – Starts

A rolling start shall be given by means of light signals. Should the lights fail, the national flag shall be used. The grid shall be made up of two lines of karts arranged in the order of the best times set during official timed practice, or the order of points obtained in the heats, or in the order of arrival position of the first final.

Article 24.1 – Rolling Start Procedure

From the moment the starter signals for the karts to be released, the drivers are under “starters orders” and may not received any outside assistance for repairs or other adjustments to their equipment while on the track.

From the moment the start procedure commences, race conditions apply. Wherever a kart is on the track it is forbidden to receive any assistance, other than to remove the kart to a place of safety.

A line will be painted 25 m before the start line and it is FORBIDDEN to accelerate before the front row of the grid has crossed this line. Karts will cover approximately one Formation Lap before the start may be given. It is forbidden to overtake another driver under pain of a penalty inflicted by the stewards. If a driver stops for any reason during the Formation Lap, he/she will not be allowed to try and start again before he/she has been passed by the whole field. He/she shall start again from the back of the formation. Should he/she try to start ahead of the field in the hope that the leading drivers overtake him, he/she would be shown the black flag and be excluded from that Race. A driver who is delayed will have the possibility of regaining his/her grid position only if this manoeuvre does not impede other drivers. In order to regain one’s position, it is forbidden to use any course other than the track used during the Race.

If he/she considers that a driver has been immobilised as a result of another driver’s mistake, the Clerk of Course may stop the Formation Lap and start again the Starting Procedure on the basis of the original grid or allow the impeded driver to regain his/her position.

At the end of the formation lap drivers will approach the start line at slow speed and in two lines. No lights will be on. No kart may accelerate before crossing the yellow line and before the green

light is turned on. If the starter is happy with the formation he/she will give the start by switching on the green light. If he/she is not happy with the formation he/she will switch on the orange light, which means another formation lap must be covered.

Article 25 – On Track Safety

Any obstructive manoeuvre carried out by one or several drivers, with or without common interests, is prohibited. The driver of any kart leaving the race shall signal his/her intention in good time and is responsible for ensuring that the manoeuvre is carried out safely and as near as possible to the point of exit. It is forbidden to use any route other than the track used for the race to gain/regain a place.

Whilst practicing or competing, karts shall not be driven other than on the defined track, in the pits, and in such other areas as Supplementary Regulations may specify. The track is the portion of the sealed surface between and including the white edge lines.

Should a driver be compelled to stop his/her kart, either involuntarily or for any other reason, the kart shall be moved off the track as soon as practical so that its presence does not constitute a danger or prevent the normal running of the race. If the driver is not able to move the kart out of the potentially dangerous position, it is the duty of the officials to assist, but only if this may be done without prejudice to their normal duties.

During practice sessions and the race, access from the track to the pits is allowed only through the deceleration zone. Penalty for breach of this rule shall be exclusion from the race, or the relevant practice session, and such other penalty as the stewards may apply. In no circumstances may a vehicle travel in a direction opposite to that of the event.

Article 26 – Mechanical Breakdown Lane

Refer Rule 17.10. From the time the race ends (chequered flag is given to the lead kart) any kart in the mechanical breakdown lane undergoing repairs has three minutes to restart and cross the finish line, to be classified as a finisher.

Article 27 – Restarting

Restarting of a kart is permitted during practice and racing. A driver should only attempt to restart a kart if it can be done with safety and without unduly hindering other competitors. Any driver not respecting this rule may be directed to remove his/her kart from the track to a place of safety.

Article 28 – Stopping the Race

If deemed necessary to stop the race due to an accident circuit blockage or because of weather conditions or other conditions make it dangerous to continue, a red flag will be displayed at the start line – all karts will return slowly to the in grid/parc ferme/service park. The procedure to be followed varies according to the number of laps completed by the race leader before the signal to stop the race was given:

- (a) If less than 2 laps have been covered, the original start will be deemed null and void. A new start will be given. For the restart, the grid used will be the one drawn up for the first start, with the Drivers allowed to take the restart in their original grid positions. Unoccupied places on the grid shall remain vacant.
- (b) If more than 2 laps but less than 75% of the distance scheduled for the race (rounded up to the nearest whole number of laps), the race will be restarted. The length of the race will be the original number of laps less the number already completed. Those Drivers having crossed the Finishing Line at the end of the lap on which the race was stopped, and those who were in the mechanical breakdown lane, when the red flag was shown will be eligible to take the restart, either in their original kart or in their reserve kart. Grid positions will be determined by the finishing order of at the end of the lap before the one on which the race was stopped.

- (c) If 75% or more of the race distance (rounded up to the nearest whole higher number of laps) is completed the karts shall be sent directly to the Parc Ferme and the race will be deemed to have finished when the leading kart crossed the Line at the end of the lap prior to that during which the race was stopped.

In events (a) and (b), working on karts will be allowed only in the Parc Ferme. Spare equipment may be introduced (only the equipment identified in the case of chassis and/or engines) and refueling will be allowed.

Article 29 – Finish

As soon as the chequered flag has been shown to a driver at the end of the race, he/she must proceed directly, using only the authorised route, to the parc ferme in the order of their finish position. From the moment the driver receives the chequered flag until he/she is released from parc ferme he/she is under parc ferme conditions and must make no alteration or adjustments to his/her kart or other material or equipment.

In the first final and second final of the Australian Championships, any driver about to be lapped or who has been lapped for any reason whatsoever as from the first lap onwards may be shown the blue and red flag (double diagonal) with his/her number. He/she must go back to the scale in parc ferme and will be classified according to the number of laps completed. Any driver who does not obey the order given by the blue/red flag may be excluded from the event.

Article 30 – Qualifying Heats

Starting positions in the qualifying heats are awarded according to classification obtained in timed practice.

Article 31 – Point Score for Heats

Each heat will have a length of approximately 10 km and points for the heats will be awarded as follows:

1st place 0 points

2nd place 2 points

3rd place 3points

and so on with 1 point being added for each place.

Any driver, who has not completed the full number of provided laps, even if he/she does not finish the heat, will be classified according to the number of laps completed.

If a driver fails to make the start they will be awarded points equal to the number of entries in the heat of that class. If any driver is disqualified from a race they will be awarded points equal to the number of entries in the heat of that class plus one.

At the end of the qualifying heats, the drivers with the lowest accumulated points will qualify for the finals. In case of a tie in total points between two or more drivers, they will be ranked according to the fastest times set in timed practice. The maximum number of competitors to progress to the first final and second final will be equal to the permitted track density.

Article 32 – Non-competition

It is the spirit and intent of the competition that all races should be contested to the fullest.

Where a competitor is considered to have missed or retired from a race in an attempt to gain an advantage, then they may be required to appear before the stewards for the appropriate action and/or penalty.

Article 33 – Final 1 Final 2

The first and second Final will be conducted over a total combined distance of approximately 50km according to the following system. Starting grid positions for the first final are according to the total number of points obtained by the qualifiers in the elimination heats, with lowest total accumulated points to the front. In the case of equal accumulated points, lowest timed practice results will determine the outcome.

Any driver, who does not complete the full number of provided laps, even if he/she does not finish the first final, will be classified according to the number of laps completed. Starting grid positions for Final 2 will be determined according to the finishing position in the first final.

Both finals shall be of equal length.

Article 34 – Reserved

Article 35 – Results

Article 35 – Results

The placings for each round will be determined by the placings obtained in the second final. Any driver who has not completed the full number of provided laps, even if he/she does not finish the final, will be classified according to the number of laps completed.

Trophies will be presented for 1st, 2nd and 3rd place getters at the completion of each round.

Championship points system for the Australian Championships

Points for Placing in Final 1 and Final 2

| | |
|-------------|--------|
| First | 25 pts |
| Second | 20 pts |
| Third | 18 pts |
| Fourth | 16 pts |
| Fifth | 14 pts |
| Sixth | 12 pts |
| Seventh | 11 pts |
| Eighth | 10 pts |
| Ninth | 9 pts |
| Tenth | 8 pts |
| Eleventh | 7 pts |
| Twelfth | 6 pts |
| Thirteenth | 5 pts |
| Fourteenth | 4 pts |
| Fifteenth | 3 pts |
| Sixteenth | 2 pts |
| Seventeenth | 1 pts |

Participation points

5 Points awarded for participating in official practice

5 pts awarded recording a time in each individual timed practice session unless excluded.

5 pts awarded by completing 75% of the laps in heat 1 unless excluded

5 pts awarded by completing 75% of the laps in heat 2 unless excluded

5 pts awarded by completing 75% of the laps in heat 3 unless excluded

- Championship points for the first final are only available to entrants who receive the start signal in the first final.
- Championship points for the second final are only available to entrants who receive the start signal in the second final.
- For the Series Champion to be crowned the Australian Champion for **K22** there must have been a minimum of 14 individual entrants across the 4 rounds of the series.

International Karting Committee

CHAPTER 44

SPEEDWAY

44.01 Track Layout

The track layout and conditions of Speedway circuits will be as agreed and approved by the State Speedway Track Inspector and relevant Government departments. Any new tracks or major alterations to an existing track, must be submitted to the State Office for all necessary inspections and approvals. **All tracks to be a minimum 8 mtrs wide throughout.**

44.02 Tyres

1. Restricted Classes must conform to the corresponding class within the current AKA Manual. (refer 23.10). Maximum wheel diameter size is 5inch.
2. Senior KT Modified Class may run any AKA approved dry/slick and/or wet tyre from the current or immediately previous year AKA manual (refer table 23.09). Maximum wheel diameter size is 5 inch.
3. Formula 100 may use any commercially available kart tyre. Maximum wheel diameter is 6 inch.
4. Dry/slick and/ or wet tyres may be hand grooved.
5. The mixing of dry/slick and/or wet tyres at any one moment, including competition, is permitted.
6. All forms of tyre treatment are illegal (refer Rule 23.03).

44.03 Weights

1. Class Weights

| | |
|--|--------------|
| Midgets – Comer Engine – Yamaha KT100J Engine | 90kg 95kg |
| Rookies | 100kg |
| Junior National (Light) | 115kg |
| Junior National (Heavy) | 135kg |
| Senior Clubman (Light) | 135kg |
| Senior Clubman (Heavy & Over 40's) | 155kg |
| Senior KT100S Modified (Light) | 135kg |
| Senior KT100S Modified (Heavy & Over 40's) | 155kg |
| Senior Formula 100 (Light) | 135kg |
| Senior Formula 100 (Heavy) | 155kg |

2. When only one single class division is competing at an event, the class weight may be the average between Light and Heavy.

3. Senior classes may have other weight division(s) and/or classes at the discretion of the Promoter. Changes to the divisions and /or weights will be as per the Supplementary Regulations for the event.
4. Maximum kart weight for all heavy classes of 83kgs.

44.04 Bodywork (Optional)

1. Side pods are compulsory and must be fitted in addition to any bodywork. Sidepods must conform to rule 25.02, excluding references to wet weather tyres under diagram, E.E, and also excluding rules 25.02 (v) & (vii).
2. Side panels (bodywork) to be fitted to either inside or outside plane of the sidepod.
3. Side panels to be made of Coreflute® sheeting only. All top edges to have plastic trim, such as fuel line or wind-lacing to be held in place with PVC glue or silastic or with Cable ties.

The bodywork side panels are not to be above the driver's shoulders whilst sitting in a normal position in the kart.

4. Internal bracing of bodywork to be of lightweight material such as aluminium angle or tubing. Sharp angles, dangerous bends are not permitted.
5. The bodywork must have no protrusions on the outer surface, (ie, fasteners must be "button" or "countersunk" type only with suitable washers to prevent pulling through the bodywork). Externals bars or plates are not permitted.

No external air ducting permitted. Ducting of any style must remain inside bodyline limitations.

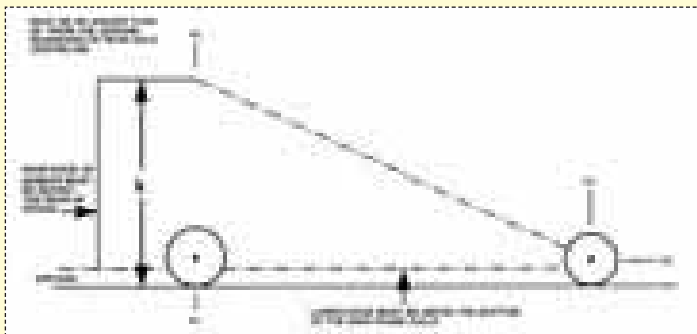

Side Number Plates

It is permissible (and highly recommended) that a side number plate made from Coreflute® of not more than 300mm x 300mm be attached to the inside of the right and left hand side pod's by means of bolt and nut or cable ties and that this plate is used to bear the entrants kart race number of a minimum size of 130mm high and 20mm wide of continuous brush stroke.

- C. Nassau Panel is compulsory and must be used as long as the panel is no wider than 500mm. The panel may extend a maximum 50mm above the top of the steering wheel and be a minimum 50mm from the outer edge of the steering wheel. Nassau Panel must be securely fixed and be of shatterproof / non-metallic material. The Nassau Panel must not restrict the driver physically or restrict their line of vision.

44.05 Air Filters

Air Filters are compulsory.

- 1 Restricted Classes must conform with AKA Manual. (refer Rule 25.24) and (Part 1 – Specific)
- 2 Senior KT Modified Class – must conform with AKA Manual. (refer Rule 25.24) and (Part 1 – Specific)
- 3 Formula 100 – are exempt from rule 25.24 (Part 1) however must comply with rule 25.24 (Part 2).

44.06 Method of Racing for Speedway

1. All racing will be in an anti-clockwise direction
2. The number of heats and method of gridding may be altered for events and will be as per the Supplementary Regulations for that meeting. They may be further altered at the discretion of the Clerk of Course and /or Promoter or by force majeure.
3. The number of laps will be as per the Supplementary Regulations or by force majeure.
4. Winner: will be determined as set out in Supplementary Regulations
5. Point Score: will be as set out in Supplementary Regulations.
6. Restarts – Rolling Laps

In the event of a collision during the rolling laps, prior to the Start, karts are permitted to be restarted with assistance by delegated person/s.

Delegated person/s must retire to a safe position once the race has commenced.

Karts that have stopped due to a mechanical defect will not be permitted to restart.

7. Restarts – Heats
No restarts by any kart. Karts are not permitted to restart if the kart becomes stationary.
8. Restarts – First lap of the Final/Feature race:
 - (i) In order to justify a race restart, two or more karts must be involved in the same incident being deemed the cause for the stoppage,
 - (ii) All karts involved in the incident, including stalled karts, will be allowed to restart at the rear of the field. Any karts not involved in the incident and that are already stationary at the time of the incident, will not be permitted to restart,
 - (iii) In this situation the Chevron Flag and Yellow Flag are to be shown until the track is clear for a restart.

44.07 Flag Signals

As per current AKA Manual (Chapter 15) except as follows:

15.06 Green Flag Start of Race

15.08 Red Flag All Racing shall cease. Driver/s will indicate by raising his/her arm and pull to the side of track and stop in a safe manner as soon as possible.

This order shall be given only through the Clerk of Course and /or Stewards of the Meeting. Red light/s may be used in addition to the red flag.

15.10 Yellow Flag

Full Course Yellow. A Yellow Flag at any flag point indicates caution, driver/s will indicate by raising his/her arm and slow down. Maintain position and form one (1) lane ready to restart as soon as the Green Flag is shown. Passing under Yellow Flag is prohibited, unless directed to by Clerk of Course. Failure to slow to a safe speed for Yellow Flag will be considered a serious breach of these rules.

15.13

Does not apply

15.14

Black and White with Diagonal join – If this flag, together with a panel upon which the competitors number is displayed to the driver concerned, it indicates that the competitor is being observed for unsportsmanlike behavior. The competitor must report to the Clerk of Course or Steward immediately after the race. If this flag together with the ROF (Rear of Field) board, is shown to a driver, it indicates that the competitor is receiving an instant penalty for a starting or other infringement, and must start/restart at the rear of the field, but in front of any provisional competitors (rule 13.18.1.c)

15.16

Does not apply

44.08 Baulk Lines

The method of determining the baulk line and its position on the circuit is to be advised by the Clerk of Course at the driver's briefing.

44.09 Numbers

1. Front and rear Number Plates will be displayed in combination that identifies the class for the kart driver.
- 2.

| | |
|-----------------|------------------------------|
| Midgets | White Number on Red Back |
| Rookies | Red Number on White Plate |
| Junior National | Black Number on White Plate |
| Senior Clubman | Black Number on Yellow Plate |
| KT Modified | White Number on Red Plate |
| Formula 100 | White Number on Black Plate |

3. In the event of two karts with the same number entering in any one class at any event where numbers are not allocated by the Promoter, the visiting driver will be issued with a special number by the Promoter.

44.10 Special Class – Senior Yamaha KT100S Modified

Eligible Engines

All, air cooled only, models of the Yamaha KT100S are eligible for use.

External Modifications

External modifications, which do not in any way affect a performance gain are legal.

Fin Dampeners

Refer to Rule 34.30

Internal Additions

- (i) No Additional material may be added except in the case of engine repairs and shall only restore engine or components to original specifications.
- (ii) The use of thermal barrier coatings / ceramic coatings on or in exhaust components is prohibited.
- (iii) The use of internal friction coatings on or in engine and/or its components is prohibited.

Interchange of Parts

Permitted between engines of like dimensions (bore, stroke) as long as no removal or addition of material is required to interchange parts.

Legal Additions

Legal additions shall be limited to the following: Carburettor return springs, chain guard, direct drive sprocket, extension of carburetor jet needles, exhaust header, motor mount, muffler, starter nut and pulley, tachometer, temperature gauge, third bearing and adaptor shaft.

Non-tech Items

Unless otherwise specified, non-tech items include bearings and cages, crankpin, fasteners, gaskets, piston and rings, header pipe, seals, piston pin, spacers, washers and spark plug.

Displacement

Maximum bore and stroke including 5% tolerances are:-

- (i) Bore – 53.85mm
- (ii) Stroke – 46.13mm

Exhaust Muffler

The exhaust system will comply with Rule 25.09.

The only permissible mufflers are those commercially available and which conform to the following diagram.

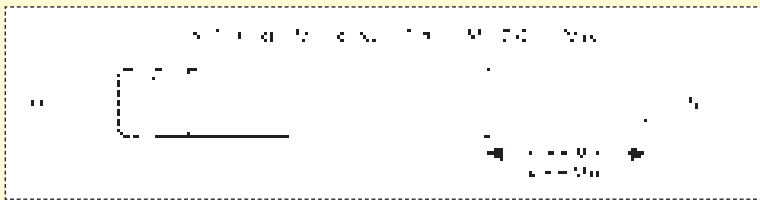

Exhaust Intake and Transfer Ports

Modifications are permitted except:

- (i) Number of transfer passages and inlet ports in the cylinder and crankcase.
- (ii) Number of exhaust ports and passages
- (iii) Port surface finish is a non-tech item.

Connecting Rod

Must be the same length as original and made of magnetic material. Can be either Yamaha or KSI.

Crankshaft

Must be by original engine manufacturer with no change of stroke permitted. Legal crankshafts are Yamaha or KSI.

Ignition

The only permissible ignition system is either of the following:

- (i) Group 2 CIK homologated
- (ii) Yamaha

The fitting of the module Yamaha, Victa, Atom or Delta/Wei Shieh is permissible. All engines must rotate in a clockwise direction when viewed from the drive side. Ignition/Rotor cover is optional.

Carburettor

- (i) Will be stock appearing WALBRO WB Series
- (ii) Maximum of two (2) jets permitted
- (iii) No Fixed jets permitted
- (iv) All fuel to the engine must pass through the high and low speed fuel metering jets and passages
- (v) All air to the combustion chamber must pass through the carburetor venturi
- (vi) Fuel pump or pressurized fuel systems are forbidden
- (vii) Squeeze type pump between fuel tank and carburetor is permitted

Fuel

Fuel shall comply with Rule 22.03

Head Gasket(s)

Must be retained

Tyres

Rule 44.02.2 Applies

Rule 44.02.4 Applies

Rule 44.02.5 Applies

Rule 44.02.6 Applies

Braking

Front wheel brakes are not permitted

Clutches

Clutches are not compulsory

44.11 Special Class – Senior Formula 100 (Reed & Rotary Valve)

Eligible Engines

- (i) Any homologated single cylinder series production reed or rotary valve, air cooled, engine, complying to CIK Formula A or Intercontinental A regulations is eligible.
- (ii) It must be possible to identify an homologated engine or its parts (cylinder heads, cylinder, crankcases and crankshaft) by the technical descriptions (photos, technical drawings and the like) on the homologation forms.
- (iii) Maximum capacity 100cc (\pm 5% tolerance).
- (iv) All systems of power-valve are forbidden.
- (v) In addition to any currently approved engines for the Formula 100 Class, newly homologated CIK engines will become eligible in the year in which they are homologated by CIK and following registration with the AKA.
- (vi) Unless otherwise specified all parts are to be by the original engine manufacturer.

External Modifications

External modifications, which do not in any way affect a performance gain are legal.

Internal Additions

- (iv) No Additional material may be added except in the case of engine repairs and shall only restore engine or components to original specifications.
- (v) The use of thermal barrier coatings / ceramic coatings on or in exhaust components is prohibited.
- (vi) The use of internal friction coatings on or in engine and/or its components is prohibited.

Interchange of Parts

Permitted between engines of like dimensions (bore, stroke) as long as no removal or addition of material is required to interchange parts.

Legal Additions

Legal additions shall be limited to the following: Carburettor return springs, chain guard, direct drive sprocket, extension of carburetor jet needles, exhaust header, motor mount, muffler, starter nut and pulley, tachometer, temperature gauge, third bearing and adaptor shaft.

Non-tech Items

Unless otherwise specified, non-tech items include bearings and cages, crankpin, fasteners, gaskets, piston and rings, header pipe, seals, piston pin, spacers, washers and spark plug.

Exhaust Muffler

The exhaust system will comply with Rule 25.09.

Any CIK homologated muffler is allowed.

Exhaust Intake and Transfer Ports

Modifications are permitted except:

- (iv) Number of transfer passages and inlet ports in the cylinder and crankcase.
- (v) Number of exhaust ports and passages
- (vi) Port surface finish is a non-tech item.

Connecting Rod

Must be the same length as original and made of magnetic material.

Crankshaft

Must be by original engine manufacturer with no change of stroke permitted.

Ignition

Only Group 2 CIK homologated ignition system is permitted.

Carburettor

(i) Carburettor to be Formula A type:

A = 24.0mm or A = 25.5mm

B = 27.8mm or B = 25.5mm

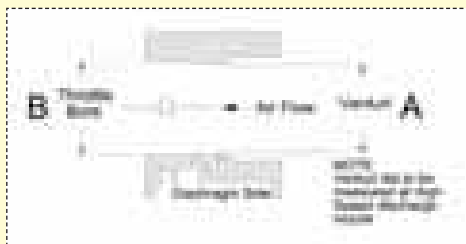

(ii) Carburettor may be either two (2) or three (3) jets – 25.4mm or 27.0mm

(iii) All air to the combustion chamber must pass through the carburetor venturi.

(iv) Fuel pump or pressurized fuel systems are forbidden

(v) Squeeze type pump between fuel tank and carburettor is permitted

Fuel

Fuel shall comply with Rule 22.03

Tyres

Rule 44.02.3 Applies

Rule 44.02.4 Applies

Rule 44.02.5 Applies

Rule 44.02.6 Applies

Braking

Front wheel brakes are not permitted

Clutches

Clutches are not compulsory

Limitations on Drivers

To be eligible to compete in this class, a competitor must hold a Senior AKA A or B Grade licence.

44.12 Starting Karts by Push Kart or Quad Bikes

- a) Drivers/riders to be 16 years or over
- b) Safety vests to be worn at all times
- c) Helmets to be worn at all times
- d) Appropriate footwear to be worn at all time (eg Boots/Shoes)
- e) All drivers/riders to be briefed by Clerk of Course on rules and safety prior to Drivers Briefing
- f) Drivers/riders to have signed waver document
- g) To be used in conjunction with local club rules and at the direction of the Clerk of Course.

CHAPTER 45

DIRT TRACK KARTING

The following rules apply to Dirt Track Racing ONLY.

45.01 Track Layout:

The track layout and conditions for Dirt Track circuits will be as agreed and approved by the State Track Inspectors.

Any new tracks or major alterations to an existing track must be submitted to the National Track Safety Committee for approval prior to construction of the circuit or alteration to the circuit.

Non-compliance with this rule will be subject to an investigation and a possible penalty imposed and / or track licence not being issued by the NKC.

45.02 Chain Oilers:

Refer Rule 25.14 – Chain Oilers: Only permitted on Dirt Tracks. (Optional to Promoters).

45.03 Tyres:

1. Tyres for classes in Dirt Track karting to be the dry weather tyre for corresponding classes in Bitumen Sprint racing.
2. Treaded tyres are not to be used.

45.04 Side Pods and Bumpers:

1. Side Pods are COMPULSORY. (Refer Rule 25.02)
2. Rear Bumper – Maximum width to centreline of rear tyres. (see diagram)

45.05 Weights:

Class weights to be the same as corresponding classes in Bitumen Sprint racing.

Promoters may change class weights if necessary, when applying for permit.

The following rules apply for Championship Administration.

45.06 NATIONAL DIRT TRACK CHAMPIONSHIP promoted in September annually.

45.07 Method of Racing for STATE and NATIONAL CHAMPIONSHIPS:

Will be at the discretion of the State Karting Council in conjunction with the Promoters.

45.08 Entry Fee for STATE AND NATIONAL CHAMPIONSHIPS:

If less than five (5) genuine entries are received for a particular class for National or State DIRT TRACK CHAMPIONSHIPS, then that class MUST be withdrawn. For State and National Dirt Track Championships, the NKC may approve other licence holders outside of the AKA.

The Entry Fee shall be decided by the State Karting Council in conjunction with the Promoters. Entries will close a minimum of fourteen (14) days before the Event.

45.09 Circuit Standard:

National and State Dirt Track Championships must only be conducted on circuits of a minimum length of 350 metres and minimum width of 7 meters throughout their entire length. Maximum length of any circuit to be 1.7km.

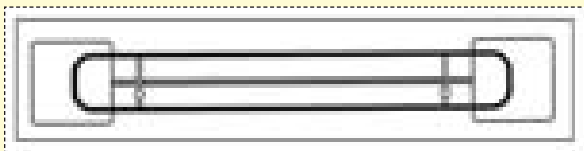

REAR BUMPER DIAGRAM

(Dirt Only)

CHAPTER 46

ENDURANCE KARTING

Organising Club to submit Supplementary Regulations to the State Office for approval and for the issuing of a race permit.

46.01 Officials and Duties

For endurance karting:

Extra Essential Officials:

- (a) At each meeting there shall be at least one Pit Marshal appointed by the Clerk of the Course.
- (b) At each meeting, there shall be at least one Refueling Marshal appointed by the Clerk of the Course.
- (c) At each meeting Flag Marshals will be appointed by the Clerk of the Course.

46.02 Parc Ferme/Paddock

- (c) For endurance karting, designated pit crews are permitted in the pit area during racing.

46.03 Formulae

- a) "Sprint racing as per Class Specifications" with "endurance karting".
- b) Numbers not applicable to endurance karting (refer section 51.13.6 hereunder)

46.04 Time For Practice

The Promoters (Club) must provide time for practice for all competitors on the day of competition or the day immediately prior to the event.

46.05 Change of Motors

10. Not applicable to endurance karting the Honda GX200 or Briggs & Stratton Animal engines.

46.06 Introduction

An endurance karting event is a speed event conducted on a circuit with a sealed surface usually with a duration of not less than one hour.

46.07 Endurance Racing Competition Regulations

1. Team Registration

All drivers/teams in an event are required to submit a completed Race Entry form for the team prior to the nominated entry closing time as specified in the Supplementary Regulations for the event. Teams may nominate a Team Name which may be a company, business or other name. This name must not be offensive to the public or other competitors.

2. Licences

Seniors and Juniors are not to mix as per the AKA Manual

The minimum licence requirements for endurance racing are as follows:

Honda GX200 class – Provisional C Grade

Briggs & Stratton Animal class – B Grade (or subject to approval of the Committee)

'P' Plate drivers are to start at the rear of the grid in their own qualifying order.

3. Required Number of Drivers

The minimum number of drivers that can be nominated for an event is as follows:

2 hours – Minimum 2 drivers

4 hours – Minimum 2 drivers

5 hours – Minimum 2 drivers

6 hours – Minimum 3 drivers

8 hours – Minimum 3 drivers

12 hours – Minimum 4 drivers

24 hours – Minimum 4 drivers

Once a race has commenced, there can be no change to the drivers nominated for that event. Cross entering of drivers between teams is not permitted.

4. Driving Limit

No driver is permitted to drive for more than 60 minutes without a driver change. A minimum break of at least 20 minutes must be taken in between driving stints. Minimum penalty for infringement: Computer lap penalty of 5 laps.

5. Compulsory Pit Stops

The number and format of compulsory pits stops required will be specified in the Supplementary Regulations for each event. As a minimum, each event is required to have the following minimum number of compulsory pits stops:

2 hour events – 4 pit stops (including the stop at the end of the event)

4 hour events – 8 pit stops (including the stop at the end of the event)

6 hour events – 10 pit stops (including the stop at the end of the event)

8 hour events – 12 pit stops (including the stop at the end of the event)

12 hour events – 15 pit stops (including the stop at the end of the event)

24 hour events – no minimum requirement

It is the responsibility of each team to monitor the number of pit stops. The electronic pit stop record is not available to teams.

Stop/go penalties do not count as compulsory pit stops.

6. Timing and Lap Scoring

All timing and lap scoring will be computerised using an electronic transponder system. Any driver, team member or pit crew attempting to interfere or tamper with this equipment, will along with the entire team, be excluded from the event and all entry fees will be forfeited. Apart from the designated official(s) no person is to touch the race computer.

It is the responsibility of the team to securely attach the transponder to the kart. If the transponder is dislocated or dislodged during the race, it is the team's responsibility to replace it. At the discretion of the Clerk of the Course, and taking into account the circumstances, time lost may be adjusted on the electronic timing system.

Transponders must be mounted on the inside of the left hand side pod with the leading edge of the transponder 250mm to the rear of the centre line of the front left hand stub axle measured when the front wheels are pointing straight ahead.

Should the timing system fail at any time for any reason whatsoever, the race will be red flagged and the race order for the restart or results will be as shown on the most recent printout or computer record.

Should a team's transponder fail, they will be credited with laps equivalent to time from the point at which the transponder ceased to function to the time they rejoin the race with a replacement transponder. The method for determining the number of laps to be credited will be to take an average lap time based on the team's performance immediately prior to the failure of the transponder. Pit or fuel stops will be taken into consideration when making such calculations. Laps will only be credited where the Clerk of the Course determine that there has been a genuine transponder failure. Note: If a battery was not sufficiently charged prior to the event by the competitor, this is not considered a genuine transponder failure and consequently any loss of laps and/or position as a result will remain.

A team will not score any points if the kart does not cross the start/finish line at the completion of the event under its own power within two minutes of the chequered flag being waved to signal the completion of the event. This result will be recorded as a DNF (Did Not Finish).

A kart may NOT exit pit lane and return to the track after the chequered flag being waved to signal the completion of the event. This result will be recorded as a DNF (Did Not Finish).

7. Qualifying

Qualifying will usually be limited to a specified maximum number of laps during a qualifying period. Any team that exceeds the maximum number of laps permitted will start from the rear of the grid. If more than one team exceeds the maximum number of laps permitted, the last team to infringe will start from the rear of the field. Note: The "out" lap and "in" lap are included in the maximum number of laps allowed.

Alternate qualifying procedures may be advised by the Promoters (Club) prior to the event.

During qualifying, drivers should be particularly aware of other karts on the circuit. The Clerk of the Course may black flag drivers who are impeding the qualifying laps of other drivers.

Weaving to warm tyres during qualifying is NOT permitted.

Tyres used during qualifying must be used to commence the race unless the Clerk of the Course indicates that there has been a change in race conditions.

46.09 Pit Area

The pit area is the area designated by the Clerk of the Course for driver changes.

Driver changes are not permitted in the refuelling or weighing area unless specifically permitted by the Clerk of the Course for a particular activity or event.

The Clerk of the Course may appoint a Pit Marshal(s) to control the pit area.

Competitors are required to obey the directions of the Pit Marshal(s) at all times.

Karts must be driven at a safe speed within the pit area (no more than 20 kilometres per hour).

Pit speed limits are applied for safety reasons and will be strictly policed and enforced by the Clerk of the Course or Pit Marshal(s). A minimum time period may be specified for a kart to travel from the pit entry to the pit exit.

No mechanical repairs or tools are permitted in the pit area. The only work permitted on a kart in this area is chain lubrication, tyre pressure adjustment using a hand pump or air bottle and tyre pressure gauge or lead/ballast changes. Only tools required for lead/ballast changes are permitted in this area and all items must be removed to a safe location immediately after use. Any breach of this rule may incur a penalty of up to 5 laps for a first offence.

Any kart removed from the circuit for mechanical or damage repair MUST be inspected by the Scrutineer(s) or Clerk of Course who are to be satisfied the kart is safe prior to being permitted to re-enter the circuit.

Chain oiling and minor mechanical or damage repairs only are permitted in this area. For repairs requiring more than 2 minutes, the kart must be removed to the paddock area. Any kart removed to the paddock area may be inspected by a Scrutineer(s) prior to being permitted to restart.

Extreme care and caution should be exercised when rejoining the circuit from the pit lane. You should only rejoin the circuit when it is safe to do so or when instructed to do so by the Pit Marshal.

Pit Area infringements may result in any of the following penalties: stop/go penalty, computer lap penalty or exclusion from the event.

During an event (including practice, qualifying and race) only the driver getting out of the kart, the driver getting into the kart and one pit crew are permitted in the pit area. Once a pit stop has been completed they are to leave the pit area immediately. One member of the team is permitted in the pit area to monitor the race and to signal the driver.

46.10 Minimum Weight and Weighing Procedures

1. Minimum Weight

The minimum weight of the kart, inclusive of driver, engines and engine oil shall not be less than 185 kilograms using the scales nominated by the Clerk of the Course at the event. Karts may be weighed at any time during qualifying, the race or at post race scrutineering at the discretion of the Clerk of the Course. Penalty for Infringement: 5 laps deducted for every kilogram or part thereof under the weight limit.

If a kart is underweight it will be required to be re-weighed. In this case the team requiring reweighing will have to wait for any other teams waiting to use the scales.

2. Fixing of Ballast to the Kart

Ballast may be added to the kart but must be firmly attached with secure mechanical fixings. Any ballast carried in the seat or seat insert must be restrained by a method deemed acceptable by the scrutineer. It is the team's responsibility to supply ballast if required. A team may be disqualified from the event if any ballast becomes dislodged during practice, qualifying or the race.

No divers belts or other methods of ballast are to be carried by drivers. It is a serious offence to have any ballast in a driver's clothing or on a driver's person.

3. Weighing Procedure

The standard weighing procedure will be as follows:

- The driver will bring the kart to the weighing area at a safe speed (no faster than walking pace).
- The driver will only proceed onto the scales when instructed to do so by the Weighing Marshal(s).
- Once the kart and driver have been weighed, the Weighing Marshal(s) will instruct them to move off the scales.
- The driver may not leave the weighing area until directed to do so by the Weighing Marshal(s).
- No contact is permitted between the driver and any other team member, pit crew or spectators.

4. Timing of Weighing

During the race, all weighing stops will be timed by the Weighing Marshal(s). The time period for weighing is to be stipulated by the Clerk of Course dependent on the circuit configuration and will be applied equally to all competitors.

5. Infringements

Weighing Area infringements, other than underweight, may result in any of the following penalties: stop/go penalty, computer lap penalty or exclusion from the activity or event.

46.11 Fuel and Refueling Procedures

1. Fuel

Permitted fuel for practice, qualifying and endurance races will be premium unleaded petrol or unleaded petrol which is readily available to the general public. Competitors are to supply fuel for qualifying and racing sourced from approved suppliers. Fuel is to be provided to the designated official(s) at scrutineering in TEKA approved containers, clearly marked with team details for return. Competitor supplied fuel is for use in the common pool fuel supply used for qualifying and racing. Competitors must provide proof of approved fuel supply source with their race documentation.

2. Refueling Area

Refueling during qualifying and races must only take place in the designated refueling area. Smoking is forbidden in this area and admission is prohibited to all persons other than the Refueling Marshal(s) and competitors refueling their karts.

3. Access to Refueling Area

The refueling area will be opened approximately one hour after the commencement of the race and will remain open for the duration of the race EXCEPT during safety vehicle periods when the refueling area will be closed. Should a team wish to refuel during a safety vehicle period, they will be required to wait until racing resumes.

4. Refueling Marshal(s)

Competitors are required to obey the directions of the Refueling Marshal(s) at all times.

5. Refueling Procedure

The standard refueling method will be as follows:

- The driver will bring the kart to the refueling area at a safe speed (no faster than walking pace).
- The driver will be responsible for switching off the engines before getting out of the kart.
- It is the drivers responsibility to activate the Electronic Fuel Timing System.
- The driver must then move away from the kart to the designated driver area or to an area as directed by the Refueling Marshal(s).
- The driver will at all times during the refueling process remain in the designated driver area.
- The driver may be required to hold and be prepared to use one of the refueling area fire extinguishers.
- The driver may only return to the kart when directed to do so by the Refueling Marshal(s).
- The Refueling Marshal(s) will replace the fuel cap(s) and restart the motors.
- The driver may not leave the refueling area until the Electronic Fuel Timing System light turns to Green or until directed to do so by the Refueling Marshal(s).

- No driver changes, mechanical or damage repairs, oiling of chains, etc may be carried out on the kart at any time whilst it is in the confines of the designated refueling area.
- No queue jumping is permitted in the refueling area unless directed by an official.
- Compulsory Fuel Marshall and Refueling Marshall must be present.
- The minimum number of refueling stops will be specified in the particular event Supplementary Regulations.

6. Timing of Refueling

During the race, all refueling stops will be timed by the Refueling Marshal(s) or by an Electronic Fuel Timing System. The time period for refueling is one minute.

7. Fuel Cap(s)

Drivers are advised to check the tightness and security of fuel cap(s) prior to leaving the refueling area.

8. Safety

Refueling has the potential to be dangerous. Any driver, team member or pit crew which recklessly endangers themselves or anyone else during the refueling process may be excluded from the event.

46.12 Race Regulations

1. Starting Grid

All karts must be taken to the marshalling / dummy grid at least five minutes prior to the commencement of the race. The pit lane will close five minutes before the commencement of the race and any karts not on the grid will start from the pit lane. Note: This may mean that the "out" lap is not electronically recorded as a race lap. In this case, there will be no computer adjustment.

2. Race Start

Karts will do the number of warm-up laps as directed by the Clerk of the Course (normally two) and will then be directed to their grid positions on the completion of the final warm-up lap. The first warm-up lap is 'free', that is, weaving is permitted; the second warm-up lap is under starter's orders and no weaving is permitted. During the warm up laps, karts are to maintain grid position. The start officials will direct karts to grid positions. Karts arriving late to the dummy grid area will start from the rear of the field. When all karts are in their grid positions the race start will be signaled.

3. Access to the Track

Unless authorised by the Clerk of the Course, apart from the driver, no team member, pit crew, spectator or other person is to access the track area during an activity or race.

4. Breakdown or Stoppage on the Circuit

Should a kart break down on the circuit the driver is permitted to carry out minor repairs to allow the kart to rejoin the race or to expedite the return of the kart to the pit area. Any repairs may only be effected by hand and no tools are permitted to be carried by the driver, on the kart or to be taken onto the circuit. No other team member may assist in any such repairs.

Repairs are only permitted once the kart and driver have been moved to a position of safety. Whilst in the confines of the track the driver must leave all protective clothing on including helmet, driving suit, boots and gloves.

Any kart damaged during racing must be returned to the paddock area for repair. It must not re-enter the circuit until an inspection has been completed by the Scrutineer(s) or Clerk of Course who are to be satisfied the kart is safe to re-enter the circuit. Karts must complete the race on two engines.

5. Safety Vehicle

A safety vehicle may be used from time to time to control the race under certain circumstances. Should the need to use the safety vehicle arise the following protocol should be observed.

A white board with the initials SK in black will be used to indicate a Full Course Caution. This indicates that a safety vehicle or slow vehicle is on the circuit or likely to enter the circuit. Competitors must slow down and maintain position. No overtaking is permitted.

In the event of a full course caution, where possible or safe, the safety vehicle will enter the circuit in front of the lead kart. If unable to enter the circuit in front of the lead kart, drivers will be waved past by the safety vehicle driver, Clerk of the Course or nominated official until the lead kart is behind the safety vehicle. Unless specifically instructed by the safety vehicle driver, Clerk of the Course or nominated official, under no circumstances do you overtake the safety vehicle. All karts must proceed in single file behind the safety vehicle.

Under a safety vehicle, karts should attempt to close up on the line of karts behind the safety kart and should not unfairly impede the progress of the kart behind. In these circumstances, the Clerk of the Course or nominated official may wave the kart behind through and may impose a stop/go penalty on the impeding kart.

As soon as a full course caution is instated, the Pit entry shall be closed to all karts. No pits stops are permitted until the field is stabilised behind the lead kart and the Pit entry is opened by the Clerk of the Course.

When the situation has been stabilized behind the safety vehicle, the Clerk of Course may open the pits for compulsory pit stops (excluding refueling), driver changes and / or repairs. Pit stops are then permitted whilst the safety vehicle is on the circuit however, you must rejoin the circuit at the end of the single file line behind the safety vehicle. Refueling is not permitted under a full course caution or safety vehicle period.

One lap prior to the safety vehicle leaving the circuit, the safety vehicle driver, Clerk of the Course or nominated official will indicate that there is one lap to go. Once the safety vehicle leaves the circuit, all karts must remain in single file and may only resume racing once your kart has crossed the start line. Minimum penalty for Infringement: Stop/go penalty.

6. Race Stoppage and Restart

In the event of a restart, the starting grid order will be as they were on the lap prior to the red flag being used to signal the race stoppage. Restarts will be single file rolling start and competitors will be given one warm up lap in single file grid order. Overtaking on the warm up lap is forbidden.

Once the lead kart has crossed the start line on the warm up lap, the race will be considered as restarted and any karts requiring entry to the pit area will be permitted to do so. Karts wanting to rejoin at this point can only do so once the last kart in the single file has gone past the pit lane exit on the warm up lap or once the last kart has gone past the pit lane exit on the first racing lap of the restart. (ie. you must rejoin at the rear of the field not the front).

During a race stoppage, karts may not be removed to the paddock area for mechanical or damage repairs. All karts shall remain in Parc Ferme area under the control of the officials. No work or re-fueling is permitted during this time.

7. Radio Equipment

Radio equipment that is able to access the race official's radio channels is not permitted in the pit / paddock area, the "out" grid or the "in" grid at any time during an event.

46.13 Offences and Penalties

1. Types of Penalties

The Clerk of the Course may impose any one or combination of the following penalties: reprimand; stop/go penalty (10 seconds to 5 minutes); computer lap penalty; place penalty; points penalty (event or championship); revision of grid position; exclusion of driver, team member or pit crew; exclusion from activity, event or championship; fine or suspension.

2. Stop/Go Penalty

In Endurance karting, a special flag (a green and red diagonal flag which will be unique for Endurance Karting) should be displayed together with a panel upon which the competitors' kart number is shown. This flag is used to signify that a stop/go penalty has been imposed on that competitor or team. When a competitor receives the special flag they are to immediately return to the pits next time he/she reaches it without impeding other competitors. The driver must complete the stop/go penalty together with any time penalty and can then rejoin the race. No driver change, refuelling, mechanical repairs, tyre pressuring or chain lubing etc is permitted during a stop/go penalty. At the completion of the driving stint, the driver must report to the Clerk of the Course or Steward immediately after returning to the Pit Area. Penalty for Infringement: An additional stop/go penalty.

3. Computer Lap Penalty

The Clerk of the Course may impose a computer lap penalty in lieu of, or in addition to, a stop/go or other penalty. The computer lap penalty may be one or more laps.

4. Forfeiture of Entry Fees

In the event that a team is excluded from an event or from the championship, entry fees are forfeited.

5. Abuse, Threats or Assault - As per the AKA Manual

It shall be regarded as a serious offence for any driver, team member or pit crew to abuse, threaten or assault any official, member, competitor, other team member or other pit crew.

6. Responsibility of Driver, Team Member or Others

The driver and/or team shall be responsible for all acts or omissions on the part of a driver, team member, pit crew or any third party attached or associated with a driver or team, but each of these shall also be responsible for any infraction of these Rules and Regulations, Supplementary Regulations or instructions given by the Clerk of the Course or nominated officials.

46.14 Kart Specifications and Regulations

1. Tyres and Hubs

Permitted tyres are as follows:

Dry – Dunlop SL1 or SL1A (Front: 10 x 4.50 x 5 – Rear: 11 x 7.10 x 5)

Wet – Dunlop KT6-SLW1 (Front: 10 x 4.00 x 5 – Rear: 11 x 6.50 x 5)

Tyres must be marked by the Scrutineer(s) prior to qualifying.

The number of sets of prescribed dry tyre and prescribed wet weather tyres allowable in an event will be specified in the supplementary regulations.

Rear hubs must not exceed 140mm in length. **Metal collars intended to prevent the axle moving laterally may be fitted to the rear axle, however these can be no more than 35mm wide each and there can be no more than 4 fitted to the axle and cannot be fitted adjacent to each other.**

2. Axle

The rear axle must be one piece, 30mm nominal diameter, solid magnetic material. Maximum overall length is 1100mm and maximum rear measurement outside to outside rim and tyre is 1400mm. Where axle keys are not the same length as the keyway, or there is a risk that the key may become dislodged, a hose clamp or other positive method of key retention is required.

Metal collars intended to prevent the axle moving laterally may be fitted to the rear axle adjacent to and inside the outside rear bearings, however these can be no more than 35mm wide and there can be no more than two fitted to the axle.

PVC or plastic sleeves fitted over the axle and intended to prevent the hub moving on the axle are permitted.

3. Sprockets

Final drive sprockets are fixed at 66 teeth. Only one sprocket may be fitted to the rear axle for each engine. (For karts competing in the B & S 'Animal' class, see Clause 51.17, final drive sprocket to be 71 teeth, subject to homologation).

4. Clutches

All karts must be fitted with dry air cooled Noram GE20-219 centrifugal clutches. Clutches will be used to transmit the drive with a maximum engagement speed of not more than 2,500 rpm engines speed.

The Noram GE20-219 clutch sprocket has 20 teeth.

5. Rear Bumper Bars

An extended rear bumper is mandatory and must be securely attached in at least two separate mounting points across the chassis. The bumper can be made from metal or high impact plastic and must be of such a construction to withstand a substantial impact. In side view the bumper must be in vertical plane. The overall width of the bumper must not exceed the rear width of the kart at any time, however must at all times cover at least 50% of the width of the rear tyre.

6. Kart Numbers and Number Plates

The kart numbers must be clearly visible, of non-reflective material and at least 130mm high and 20mm wide; generally as per to Clause 25.13 of this AKA Manual, except as specified herein.

Number plates shall be coloured as follows:

Honda Class Yellow background with Black number(s)

Briggs & Stratton Class Red background with White number(s)

Division N White background with Red number(s)

Numbers are required to be mounted on the side of the kart, together with the front NASA panel and on the rear.

The kart numbers must be clearly visible, of non-reflective material and at least 130mm high and 20mm wide.

Provisional Licence Holders must display a regulation red "P" on a white background on the rear of their helmet.

7. Steering

For endurance karting solid plastic/nylon tie rods with a minimum outside diameter of 20mm and fitted with metal rose joint connectors are permitted.

46.15 Engine Specifications and Regulations – Honda Class

1. Engines

The only permitted twin power plants are standard 6.5hp Honda GX200 series QXU engines in as supplied condition from Honda MPE Australia or it's appointed agents. Note: Honda MPE Australia will admit no warranty claims on engines used in practice or racing.

Engines will be mounted on each side of the kart at the rear and drive the kart through chains.

2. Modifications

Modifications to engines are strictly limited to the following:

- Removal of the governor mechanism and oil switch. If the whole mechanism is removed, the holes in the crankcase must be sealed to prevent oil leakage.
- Fitting of alternative exhaust valves (Honda Part No. 14721-ZH8-810)
- Fitting of alternative valve springs (Honda Part No. 14751-ZH8-940 or 14751-ZE1-000)
- Fitting of alternative carburettor jets
 - Size 68 (Honda Part No. 99101-ZF5-0680)
 - Size 70 (Honda Part No. 99101-ZF5-0700)
 - Size 72 (Honda Part No. 99101-ZF5-0720)
 - Size 75 (Honda Part No. 99101-ZF5-0750)
- Substitution or complete removal of the air filter is permitted, however the outer air filter casing must remain as standard and in place. No modification to the outer air filter housing is permitted.
- The linkage connecting the throttle cables to the standard carburettor throttle arm is free and it is permitted to fit throttle return springs to each carburettor.
- Spark plugs and caps are free; however no spark enhancers or boosters are permitted.

Apart from the modifications above, no engine parts other than genuine Honda parts, as specified for this engine type, may be used. Furthermore, it should be noted that the terms "standard" and "genuine" refer not only to the components used but also to the number used and the manner in which engines are assembled. Apart from the modifications specifically mentioned in these regulations, the engines should be completely standard and all components should remain in place unless it specifically states that you are allowed to remove them.

Reboring of the engine or regrinding of the crankshaft is not permitted. No sleeving or surface material change to the bore is permitted. No other metal removal from any component is permitted.

No polishing of the cylinder head, combustion area, inlet tract or exhaust port tract is permitted.

Chemical agents must achieve carbon removal only. It would not be expected to see casting marks or imperfections removed.

Remote engine kill switches are permitted however the standard start/stop switch must be retained and must function independently of any remote engine kill switch.

3. Fuel System

The only permissible fuel tank shall be a central fuel tank with a maximum capacity of 9 litres. A fuel tank with a capacity greater than 7 litres must have a line clearly and permanently marked on the fuel tank by a scrutineer to indicate a 7 litre fuel level. Refer Rule 22.04.

When refuelling, it is not permitted to fill the fuel tank past the 7 litre mark. The tank may be fitted to the kart with a quick-change mechanism to allow for ease of refuelling; any such quick-change mechanism must be to the acceptance of the scrutineers as to its safe installation / operation.

Pulse Pumps can be fitted using either the original hole used by the governors once they have been removed or by utilizing the inlet manifold. If via the inlet manifold, the fitting used must be a commercial off-the shelf product with no modifications and must protrude into the inlet port no less than 0.5mm, thus making de-burring unnecessary. If the port is modified in any other way the engine will not pass scrutineering.

4. Non Tech Items

1. Fuel Filter, Clamps, Pulse Line, Switches, Ancillary Mounts, Fasteners, Circlips, Washer, Bearings, Springs, Exhaust Support Brackets, Chain Guards, Chain Guard Brackets.
2. No alteration from the original manufacturer's specification is permitted to fit a non-tech item.
3. Addition fasteners or securing devices are non-tech items and may be fitted/added, to the Scrutineer(s) satisfaction.

46.16 Engine Scrutineering

Engine Scrutineers will be approved and appointed from time to time. Only approved Engine Scrutineers may inspect and seal engines. Engine Scrutineers may charge a fee for this service.

A list of currently approved Engine Scrutineers is available on request and is included in Appendix A, for those at the time of publication of this Manual.

The Engine Scrutineer will pay particular attention to the finish of all components to ensure that they match the standard unit. The Engine Scrutineer may check and compare any suspect component with a standard part as supplied by Honda MPE Australia. Checks and measurements may be carried out to ensure that tolerances are within those specified by Honda.

Engines will be sealed by the Engine Sealer using lock wire and lead or plastic seals.

The Engine Sealer shall keep a record of the engine numbers of engines sealed for endurance karting events.

Engine seals will be inspected by the Scrutineer(s) prior to each event. It is the teams responsibility to ensure that engine seals are intact and in place. If a seal is broken the engine must be represented to the Engine Scrutineer for inspection and sealing. No engine inspections or sealing will be available at events unless specifically requested or approved by the organiser or the Engine Sealer.

At the conclusion of an event, the organizers reserve the right to inspect any kart in any way to satisfy compliance with these specifications.

At the conclusion of an event, the organiser reserves the right to take away any engine or engines for inspection and/or dynamometer testing if they wish. If any infringement is found to exist the team will be liable for any inspection fee.

46.16 Engine Specifications and Regulations – Briggs & Stratton Class

The only eligible engine is the Briggs and Stratton Animal, Model 124332.8003.01.

For use in events conducted by TEKA, every engine must have the Official TEKA seal on the crankcase and also on the cylinder head. Each engine will be delivered from TEKA with its own engine IDENTITY Log Book and TEKA serial number

Only Authorised TEKA engine sealers and Authorized Service Centres for Briggs and Stratton motorsport products are allowed to seal engines after carefully checking the engine according to the Technical Specification for the Briggs and Stratton Animal engine type. Special TEKA seals must be used. A record of any and all repairs / rebuilds to all motors is to be entered into the log book, signed, dated and stamped by the authorised service centre or TEKA engine sealer.

A list of Authorised Briggs & Stratton Service Centres is set out at Clause 51.16.4.

At race scrutineering, the driver is to present the engine with an undamaged seal and the engine with log book, showing the matching engine serial number, seal number, stamp and signature of the authorised TEKA engine sealer, who sealed the engine. This procedure helps to reduce scrutineering times at races, nevertheless in the case of a protest, it is possible for the scrutineers to open and check the engines before or after the race. Any post race scrutineering will be in accordance with this clause 51.16.

After checking the engines step by step to ensure it is in accordance with the Technical Specifications hereunder, the AKA Technical team and in conjunction with the staff of the Authorized Service Centre or TEKA engine sealer will reseal the engine.

Only genuine Briggs and Stratton components that are specifically designed and supplied for the Animal engine are permitted, unless otherwise specified. Neither the engine nor any of its ancillaries may be modified in any way. 'Modified' is defined as any change in form, content or function that represents a condition of difference from that originally designed. This is to include the addition and/or omission of parts and/or material from the complete engine assembly unless specifically allowed within these rules.

Internal additions: no additional material may be added except in the case of engine repairs and shall only restore the engine or components to original specifications.

- The use of thermal barrier coatings/ceramic coatings on or in the engine and on or in the exhaust system is prohibited.
- The use of anti-friction coatings in or on the engine/engine components is prohibited.

Permitted additions: Chain guard, engine mount, and tachometer/hour meter, inline fuel filter, catch can mounting brackets and mounting brackets, within the limits specified in this document.

Non-tech items: non-original fasteners, circlips, washers, throttle cable and housing, Fuel and pulse line (type and size) are allowed unless otherwise specified.

Shrouds: Flywheel shrouds must not be altered in any way to alter the airflow or change appearance.

Switch: The ignition kill switch may NOT be removed and must function. Remote engine kill switches are permitted however the standard kill switch must be retained and must function independently of any remote engine kill switch.

Cooling Fan: The only fan that is allowed is as stock and unaltered.

Valve Springs: Valve springs may not be heated and or stretched. Shimming is not permitted. The springs must be a Briggs and Stratton part No.26820

Bearings: Main bearings must remain as a press fit in the block after the engine has attained ambient atmospheric temperature. Loctite type compounds, pocket dimpling/knurling or any other form of retaining devices are NOT permitted. Main bearings must be standard, unaltered, genuine Briggs and Stratton parts manufactured and listed for the Animal engine.

Block: Block must be an original Briggs and Stratton Animal part No 555687. Block must be in original cast condition. Welding to repair cracks or breakage is allowed only in areas where the affected portion does not require re-machining and not in an area where the welding may be construed as a performance gain.

Cylinder Head: No alteration, modification is permitted to the head or head gasket surface. Valve seats may not be re-seated shallower in the head. The entire inlet and exhaust tract surfaces must remain STOCK. Thread saving devices in the spark plug hole are permitted but must be installed so that the combustion chamber volume test will be the same as with the original thread.

Head Gasket: Head gasket may not be altered in any way.

Valve Cover Gasket: Stock valve cover gasket must be OEM as supplied by Briggs & Stratton.

Valves: Valves must not be altered, polished, lightened, welded, grazed, or machined in any way. The original valve set angle must be maintained. The valve guides may be replaced as a means of repair but must be retained to standard dimensions. Lapping of valves / seats is permitted subject to the above limitations.

Piston and Rings: Re-sizing, knurling, or lightening of pistons is not permitted. The use of piston button or buttons is not permitted.

Coating of pistons is not permitted. Anodizing of a piston is not permitted. All three piston rings must be used, installed correctly, with the identification marks toward the head. Ring tension may not be changed by heating or other means. Ring gaps are not subject to technical inspection. The ends of each piston ring may only be altered in a way that appears to be the same as a known, stock, unaltered, ring for the engine. The piston oil control ring (third ring) may only be OEM rings, appropriate for the engine.

Camshaft: No alteration, additions, removal of material, modifications or machining of any kind is permitted.

Crankshaft Gear: The crankshaft gear can not be rotated to change the camshaft timing on this engine.

Flywheel: Must be stock and unaltered.

Shrouds: The cooling shrouds must be present and unmodified.

Ignition: Only OEM parts are permitted. Ignition timing can not be altered from stock. Coil mounts are not to be modified in any way so as to change ignition timing.

Spark Plugs: Spark plugs, leads and caps are free; however the plug reach is to be 19mm with 19.2mm being a maximum, measured from the upper gasket surface of the spark plug to the parallel lower squared edge of the threaded portion of the plug. No spark enhancers or boosters are permitted.

Carburettor: No alteration, modification, or machining of ANY kind is permitted of ANY part of the carburettor, unless specifically stated in this document. The choke assembly and all components must remain completely intact and stock.

The air filter is free. The air filter must be attached directly to the original air intake bell of the standard Briggs & Stratton carburettor. Welding and bracing of the inlet manifold is permitted provided that overall dimensions and location must be as per original, nor modified in any other way, nor may any material be removed from the inlet manifold in the process.

Fuel Systems: Pulse Pumps can be fitted using either the original hole used by the governors or by utilising the oil filler cap or the inlet manifold. If via the inlet manifold, the fitting used must be a commercial off-the shelf product with no modifications and must protrude into the inlet port no less than 0.5mm, thus making de-burring unnecessary. If the port is modified in any other way the engine will not pass scrutineering. No electric fuel pumps are permitted.

Spark Plug Gasket: A gasket and or a temperature gauge sensor must be installed under the upper surface of the plug. The height or thickness of the gasket or sensor must be greater than 0.1mm.

Clutches: All karts must be fitted with dry air cooled Noram GE20-219 centrifugal clutches. Clutches will be used to transmit the drive with a maximum engagement speed of not more than 2,500 rpm engines speed. The Noram GE20-219 clutch sprocket has 20 teeth.

The final drive sprocket for use in the 'Animal' class is fixed at 71 teeth.

46.16.1 ENGINE TECHNICAL SPECIFICATIONS

Bore: Maximum bore is 68.3mm

Stroke: Maximum stroke 27.9mm

Valves: Intake & exhaust valve length = 85.65mm \pm .25mm; Single angle cut Intake Valve: Head diameter = 26.8mm 'no-go', 27.05mm 'must-go'

Valve dish: 2.51mm to 3.01mm.

Height from angle of valve face to top of valve = 1.45mm 45 degree cut

Exhaust Valve: Head diameter = 23.75mm 'no-go' to 24mm 'must-go'

Valve dish = 2.15mm to 2.65mm

Height from angle of valve face to top of valve = 1.5mm

Valve Springs: Intake and exhaust valve spring maximum length = 23.65mm 'no-go', Wire diameter (measured in 3 places) 2.6mm – 2.7mm

I.D. of spring 15.65mm minimum to 16.1mm maximum

Valve Seats: Intake seat I.D. = 24.55mm must-go to 24.7mm no-go

Exhaust seat I.D. = 21.45mm must-go to 21.6mm no-go

Seat angles: 45 degrees, single angle cut.

Valve Lifters: Head = 20.8mm no-go to 21.85mm must-go

Length = 38.5mm no-go to 38.75mm must-go.

Push Rod: 4.7mm – 4.8mm diameter; 143.2mm – 143.6mm length

Connecting Rod: Length between axes = 83.5mm

Length from bottom of wrist pin to top of crankshaft journal = 61.45mm minimum to 61.7mm maximum

Crankshaft: Main journal diameter: 27.8mm to 27.95mm

Cylinder Head: Depth of head at shallow part of head = 0.3mm minimum. The measurement on the shallow side of the combustion chamber is taken with a depth gauge on the push rod side of an imaginary line drawn from dowel pin to dowel pin on the valve side of the dowel. It is also taken over the spark plug area.

Depth at floor of head = 8.1mm minimum.

Depth to top of valve seat = 9.15mm maximum to 8.5mm minimum

Head thickness measured from head gasket surface to head plate gasket surface = 61.5mm (measured in four places through valve guides and push rod holes).

Width of combustion chamber at the widest part across the valve seat area 67.05mm no-go at a depth of 5.1mm in the combustion chamber. Cylinder head combustion chamber volume is 28.5cc

Piston Rings: 2 compression and one oil ring used

Compression ring minimum width = 2.4mm

Compression ring thickness = 1.5mm – 1.65mm

Oil ring minimum width = 1.65mm

Oil ring thickness = 2.5mm to 2.6mm; Oil ring expander must be installed.

Piston: Minimum piston length = 44.9mm

Measurement from top of piston to wrist pin bore (on circlip side of piston) = 16.7mm

Camshaft: Camshaft must be unaltered Briggs & Stratton and to the standard specifications as provided by Briggs & Stratton.

46.16.2 EXHAUST SYSTEM

Complete exhaust manifold and muffler assembly must be as homologated and as supplied by TEKA with all motors. All mufflers shall be tagged, stamped or engraved with TEKA permanent **identification** by TEKA. Muffler mountings and bolts are 'free'.

46.16.3 SCRUTINEERING PROCESS

(a) Pre-Race Scrutineering

TEKA Engine Log Books, one for each engine, must be presented at Pre-Race Scrutineering and when requested by AKA Scrutineers.

(b) Rebuilding & Resealing

B&S Animal engines can be taken to an engine builder and rebuilt to standard specifications. Full AKA homologated B&S Animal specifications are available on the TEKA website. TEKA currently have (3) nominated B&S Motorsport Dealers that are fully equipped to rebuild, service and seal Animal engines. Contact details are available on the TEKA website. Engine Builders are required to fill out the service part of the Engine Log Book, including the type of service performed and any parts required. Engine Builder contact details must also be added to Log Books as part of its service. It is the competitor's responsibility to insure that Engine Log Books are filled out correctly. Only a TEKA sanctioned Engine Sealer or nominated B&S Motorsport Dealer may seal your Animal engine. To ensure fairness for all competitors and engine sealer may NEVER drive or compete in a kart that has been sealed by them. Furthermore no Animal engines can be sealed by the same Engines Sealer more than (2) consecutive times.

(c) Post-Race Inspection

As per AKA rule 51.15, TEKA reserves the right to take away and inspect any Animal engines at the completion of an event. Competitors are advised to carry their original B&S engine boxes to race meeting to assist TEKA with transportation. Engines impounded by the scrutineers will be placed into the transport box, the box sealed until ready for off-site inspection in accordance with AKA processes. The corresponding Engine Log Book must accompany each engine as part of the technical inspection process. Competitors will receive a receipt for each engine taken and advised of a time and place to attend the technical engine inspection.

After an engine passes inspection – unless otherwise agreed with the competitor – engines will be returned re-sealed at no cost to the competitor. Inspection details and new seal numbers are recorded into the Engine Log Book.

Note: Mandatory TEKA technical inspections and subsequent re-sealing does not reset an engine's consecutive engine sealing count.

(d) Anomalies

In the event that an engine is deemed to be illegal the competitor will be disqualified from the event. The AKA Technical Scrutineers decision is final. If an engine is deemed by the scrutineers to be illegal, all costs incurred in the inspection are to the account of the competitor. The so deemed illegal motor will be returned to the competitor unassembled and may be returned for re-scrutineering and certification after any illegalities have been corrected.

46.16.4 APPROVED BRIGGS & STRATTON MOTORSPORT DEALERS FOR TEKA SEALING

The following Briggs & Stratton Dealers are authorised to carry out sealing of motors in accordance with this chapter:

Norwest Mowers

Unit 3, 1 Forge St.

Blacktown, 2148

Ph: 02 9622 5285

Contact: Kevin Williams

Fitzgerald Motors

9 Fitzgerald St.

Windsor, 2756

Ph: 02 4577 3401

Contact: Murray Hayes

Unanderra Mower Centre

51 Princes Hwy.

Unanderra, 2526

Ph: 02 4271 1340

Contact: Tom Hamilton

CHAPTER 47

VINTAGE KARTING

The Class of Vintage and Historic Karting are providing an avenue for the demonstration and preservation of Karting History.

A Vintage Kart is as defined in the AKA approved regulations of the VHKA available from the AKA or directly from the VHKA (address as listed in this manual)

47.01 Licences

1. The minimum licence requirement for Vintage Karting is an AKA V licence
2. Any suitably – endorsed AKA sanctioned Senior Licence is acceptable.
3. All licences issued shall comply with the applicable rules in Chapter 13 of the AKA Manual.

47.02 Application for Vintage Licence (V Licence)

1. The licence application must be accompanied by two current passport-type photographs (jpeg electronic format preferred) and the relevant fee.
2. Applicants for a new licence or renewal of an existing licence must be a member of an AKA affiliated Club as per chapter 13 and must remain a financial club member during the licence period.
3. Applicant must be at least 18 years old.
4. Applicants aged 60 years or over must supply a copy of a current AKA Motor sport Medical Certificate with their licence or renewal application.
5. This certificate must refer to an examination within the three months prior to the application.
6. All applications are made through the relevant State body as per chapter 13, and subsequently endorsed by the VHKA.
7. As a minimum training requirement, applicants must complete a flag Questionnaire and attend an AKA safety Training lecture.

47.03 Kart Registration

1. Vintage Kart Registration is granted by the VHKA. All Karts must be registered with the VHKA and show their registration plate to be eligible for Practice and Demonstration on AKA tracks.
2. Once registered, a Kart will be issued with a registration sticker This is to be presentable at all times as proof of registration. Contact VHKA for fee for registration. The owner of a Vintage Kart must be a member of the VHKA before applying for registration.
3. Once registered, a Kart will be issued a log book as per clause 53.04.1.
4. Kart registration only remains valid while ever the owner has financial membership of the VHKA.
5. The VHKA issues yearly stickers displaying the year of registration.
6. Yearly stickers must be attached to the registered kart and applicable kart's log book, indicating the kart's owner is a current VHKA member and has not been issued with any major penalty.
7. To be eligible for registration, a kart must be original, an original restoration or a faithful replica. Three photographs (front , side and rear) must accompany the registration application.

8. The kart can only be driven on any AKA facility if specifications and appearance match the issued log book.

47.04 Kart Log Book

1. All Vintage Karts must be accompanied by a VHKA – issued Log Book. This log book is to be available as proof of registration for scrutineering and operation on an AKA track.
2. Log Books will be issued by the VHKA upon completion of Registration.
3. The Log Book will clearly identifies the Kart, including the registration number and records the Model, Year and Relevant Class or Classes of the Kart .
4. The log book must contain at least 3 photo's showing front, rear and side views of the kart. Photos must be clear enough to identify the features of the kart.
5. Any alterations to the kart should be in keeping with the original log book specifications. In the case of motor substitution, the alternate motor must be complaint with the era listed in the log book.
6. When a Vintage kart changes ownership the current logbook is transferred to the new member for registration with the VHKA.

47.05 Vintage Demonstration

1. An Organising Club is to submit an application to the relevant state body for conducting a vintage demonstration. The state body will then liase with the VHKA to issue an approval. The organising club to submit the supplementary regulations, clearly identifying "for Vintage Demonstration " to the relevant state office for approval and race permit issue.
2. All Drivers must be AKA licensed in accordance with 53.02.
- 3 Drivers who have no previous kart-driving experience must start at the rear of any field.
4. Chapter 14 to apply or period-correct clothing including helmets will be worn.
5. Licensed Drivers (53.01), with registered Karts (53.03) can participate in Vintage Practice on AKA approved Tracks. Refer to rule 13.20 (d).
6. Fastest karts to front, slowest to rear, in their class when leaving grid. Karts must grid up for 3 parade laps – Karts wishing to show their full potential must do so in a safe manner. There will be no over taking at high speed. Kart will not race each other and be no closer than 2 meters apart.

If during a demonstration anyone is found to be driving in a Dangerous manner or racing by the stewards /Clerk of Course of meeting they will be given a black and white diagonal flag as per 15.14, this will be the first warning, if a black flag is given, you MUST return to the in Grid within the lap it is shown and you will be excluded from any further demonstration/s at that meeting.

The Stewards/Clerk of Course will be Judges of fact (this is only for Kart demonstrations)

7. Demonstration – the number of karts on the circuit will be 50% of the tracks licenced capacity. stewards of the day.

47.06 Scrutineering

1. All Vintage Karts must be inspected by a scrutineer at AKA permitted meetings
2. Karts will be examined against log books, confirming no major alterations or additions have been made.
3. The scrutineer will inspect each kart against relevant rules of the era raced, year and class as per log book.
4. When the scrutineer is satisfied that the kart is compliant, a sticker, containing the date, track and class will be issued. The sticker must be placed on the kart in a visible location.

47.07 Recognised Classes

1. Pre 1962: Historic
2. 1963 – 1969: Vintage
3. 1970 – 1980: Classic (pre side pod karts)
4. 1981 – 1991: Post-Classic Kart
5. 1992 onwards: Modern Classic Kart. To be eligible, a kart/ class must have been removed from the general AKA manual after 1991.
6. Super engine – 130/200cc Rotary & Reed. Karts must be pre – side pods with pre-1988 engine(s).

TYRES:

Tyres shall be the same size, profile and equivalent compound as originally raced. Tyres for all classes will be as provided for in the relevant AKA manual for the year of the kart.

For classic, Post Classic, Modern Classic and 200 super classes the default tyre shall be of SL type.

AUSTRALIAN KARTING ASSOCIATION SUPPLEMENTARY REGULATIONS

These regulations may be contained within the supplementary regulation for any general race meeting or issued as a separate document, but in either case must be approved by the AKA State Body in which the event is to be held.

1. Organisers

Insert here the name and address and phone numbers of the organising club.

2. Date and Place of Meeting

Insert the date(s) of the meeting and the name and address of the circuit. At some circuits it may also be necessary to specify the specific track to be used and the direction of racing.

3. Vintage Scrutineer/s / appointed official

At all meetings at least one suitably – qualified VHKA – appointed official will be nominated to assist the general meeting officials with scrutineering and while karts are in operation.

4. Timetable

Close of entry

Scrutineering

Official demonstration only

Separate Vintage Kart Drivers Briefing

5. Insurance

Insurance has been affected for this meeting in accordance with Chapter 3.

DRIVERS INDEX

| | |
|---|---------------------------|
| Abandonment or Postponement | 1.25 |
| Abuse or Intimidation of Officials | 5.01 (a) (b) (c) (d) |
| Acceleration Line | 17.06 |
| Advertising | 1.23 |
| Airbox | 25.24 |
| AKA Registered Silencer | 25.22 / 25.23 |
| Alcohol / Drugs Testing | 1.33, 1.34 |
| Alcohol/Drugs | 1.33 / 17.16 |
| Ambulance | 3.25 / 3.26 / 3.27 |
| AMSAC | Chapter 10 |
| Announcement of Jurisdiction | 1.05 / 1.08 |
| Appeals | Chapter 8 |
| Appeals Exceptions | 7.04 |
| Appeals-notice of intention | 8.04 |
| Appeals-time limit | 8.04 |
| Approved Tyres | 23.09 |
| Assistance Before Start - Jnr / Rookies | 16.10 (c) (i) and (e) (v) |
| Auto. Exclusion 5.01(q),(r),(o) | 5.02 / 5.03 |
| Baulk Line/Reaching Same | 17.04 / 17.05 |
| Baulking another driver | 16.27 |
| Bead Retention | 23.02 |
| Black Flag | 15.15 |
| Black/White Chequered - Finish Flag | 15.17 |
| Breaking Start | 16.09 (vi) / 5.04.1 |
| Breathalyser Testing | 1.34 |
| Change of Chassis/Frame | 1.29 |
| Change of Motor | 1.30 |
| Change of Tyres | 1.32 / 23.11 |
| CIK | Chapter 43 |
| Circuit Standard / Length | Chapter 19 & 20 |
| Cleaning Fluid In Pits-Kerosene | Chapter 19 & 20 |

DRIVERS INDEX

| | |
|--|------------------|
| Combine Classes | 16.06 |
| Commencement of Meeting | 1.13 |
| Communications | 17.13 |
| Complaint Against Judge Cannot Be Lodged | 7.04 (b) |
| Complaint Against Official | 7.07 / 7.18 (a) |
| Complaint Cannot Be Lodged | 4.17(d) / 7.04 |
| Complaint Not Dealt With By Stewards | 7.17 |
| Complaint/Appeal Cannot Be Lodged | 5.04 |
| Complaint/Call Person | 7.26 |
| Complaints (time limit) | 7.14 |
| Complaints / Exceptions | 7.04 |
| Complaints | Chapter 7 |
| Consolidation of classes | 16.06 |
| Consumption of Alcohol / Drugs | 1.33 |
| Contact of Karts | 16.23 |
| Cross Entry of Engine-Nationals Only | 1.30.8 |
| Cylinder head volume testing | 26.01 |
| Dangerous or Over-aggressive Driving | 16.23b |
| Dangerous Re-Entry to Track | 16.18 |
| Data Logger | 25.16 |
| Defective Kart | 12.01 (d) / 1.20 |
| Degree of Proof/Balance of Probability | 9.08 |
| Direction of Racing | 16.15 |
| Dirt Track | Chapter 45 |
| Disabled Drivers | 13.10 |
| Disrepute, Bring Sport Into | 5.01 (d) (e) |
| Draw-Winner Of | 16.14 |
| Driver's Briefing | 16.02 |
| Drivers Responsibilities | 1.05 / 13.11 |
| Driving in Opposite Direction | 16.15 |
| Driving Off Track / Rejoin | 16.18 |

DRIVERS INDEX

| | |
|---|-------------------------|
| Driving Suit (number of) | 14.03.2 / 14.06 / 14.09 |
| Drugs in Sport Policy | Refer to AKA website |
| Ducking Head | 16.24 |
| Duties Of Judges | 4.17 |
| Duties Of Lapscoreers | 4.23 |
| Duties Of Noise Control Marshal | 4.22 |
| Earplugs / Spectators | 24.8.7 |
| Earplugs / Supplies | 24.8.8 |
| Earplugs | 24.8.1 / 14.11 |
| EGT Probe | 25.08 , 25.09.7 |
| Eligibility to Race Final | Chapter 18 |
| Engine Measuring | 1.21 & Chapter 26 |
| Engine Replace | 1.30 (3) (5) |
| Engine Sealing | 1.30 (9) (10) / |
| Engine Seals / Tags - Loss of | 1.30 (10) c |
| Engines / Number of and Number of Seals | 1.30 (1) |
| Essential Officials | 4.03 |
| Excessive Speed on In Grid | 16.23 (b) |
| Exclusion From Event-Consequence | 6.02.8 |
| Exclusion from meeting-Consequence | 6.02.9 |
| Exclusion From Race/Heat-Consequence | 6.02.7 |
| Exclusion Notice of intention of appeal | 8.11 |
| Exclusion-Alcohol | 1.33 |
| Exclusion-Automatic | 5.02 / 5.03 / 12.02 (b) |
| Exclusion-Fail to Submit for Inspection | 12.02 (b) |
| Exclusion-Identifying Marks | 1.16 |
| Exclusion-No Practice | 16.04 |
| Exhaust Muffler | 25.22 |
| Exhaust System | 25.09 , 25.08 |
| Exotic Compounds - Carbon Fibre | 25.20 |
| Fail or Refuse to Present Kart | 5.01(s) / 12.02 (a) (b) |

DRIVERS INDEX

| | |
|--------------------------------------|-------------------------|
| Failure to Obey Instructions | 5.01 (w) |
| Faulty Transponder (Time Trials) | 16.05 (b) |
| Fees | Chapter 2 / 1.12 / 8.04 |
| Fin Dampeners (S) | 24.9 |
| Finishing Under Power | 16.26 |
| First Aid | 3.26 / 3.27 |
| Flag signals | Chapter 15 |
| Frivolous Complaint Or Appeal | 5.01 (m) |
| Fuel - Additives | 22.03 (4) |
| Fuel - Controlled | 22.03 (7) |
| Fuel - Random Samples | 22.02 / 19.27 |
| Fuel (illegal) | 5.01(q) |
| Fuel testing | 22.01 |
| Fuel | Chapter 22 |
| General Offences | Chapter 5 |
| Gridding (system of) | 16.07 |
| Guards (chain/engine) | 25.11 |
| Heat guns / heating devices | 17.14 / 23.03 |
| Helmet / Midgets / Rookies Only | 14.01 (5) |
| Helmet / Safety Apparel Within Track | 16.20 |
| Helmet Damaged | 14.01 3 |
| Holding a Line | 16.27 |
| Homologation | Chapter 21 |
| Illegal Engine or Part | 5.01 (o) / 5.02 |
| Incorrect Grid Position | 16.09(i) |
| Injured Driver Clearance | 16.22 |
| Inspection /Kart/Apparel | 12.02 (a) (b) |
| Insurance | 1.11 & chapter 3 |
| Intimidation | 5.01 (a) (b) (c) |
| Judge of Fact - No Complaint | 4.17 (d) |
| Judge of Fact | 4.17 |

DRIVERS INDEX

| | |
|---|--------------------|
| Junior Facing Stewards | 7.29 |
| Kart direction | 16.15 |
| Kart formula | Chapter 25 |
| Lapping Kart | 16.19 |
| Late Entry | Chapters 19 & 20 |
| Leaving / Rejoining Circuit | 16.18 |
| Licence - Period of Competition Licence | 13.08 |
| Licence - Over 60 yrs | 13.01.5 / 13.16(f) |
| Licence -Age Divisions | 13.04.1 |
| Licence -Age Overlaps | 13.19 |
| Licence Endorsement D Grade | 13.15.2(b) |
| Licence Endorsement B Grade | 13.15.4(a) |
| Licence Endorsement Formula A | 13.21.4 (d) |
| Licence Endorsement Street Race | 17.17 (vii) |
| Licence Grades | 13.15 |
| Licence Grading Temporary Circuit | 17.17 (vii) |
| Licence Required to Produce Same | 13.14 / 20.18.d |
| Licence, Unable to Produce | 13.13 |
| Licences | Chapter 13 |
| Light Signals / Flags | 15.03/04 |
| Light signals | 15.19 |
| Limitation on Driver – R125 | 37.01 |
| Limitation on Drivers - Formula 100 | 41.01 |
| Local Club Events | 1.27 |
| Long Hair | 14.08 |
| Max Weight of Kart | 25.19. 2 |
| Mistake by Judge | 4.17 (f) |
| Motors liquid cooled | 25.18 |
| Motors/Change of | 1.30 |
| Mufflers-Headers | 25.08, 25.22 |
| Multiple Entry of a Kart/engine | 1.30.8 |

DRIVERS INDEX

| | |
|---|-----------------------|
| No Appeal (Scrutineers Report) | 12.01 (d) |
| No Complaint against Judge | 4.17 (d) |
| Noise Control | 24.1 |
| Noise induction silencer (adaptor) | 25.25 |
| Noise induction silencer (airbox) | 25.24 |
| Noise Level-Permitted | 24.2 |
| Noise Measuring Equipment | 24.4.1 |
| Noise Penalty | 24.7 |
| Noise | Chapter24 |
| No-Man's Land | 16.09 (v) / 17.07 |
| Nose cones | 25.06 |
| Number Plate (third) | 25.13 (iii) |
| Number Plates | 25.13 |
| Numbers (same numbers in one class) | 25.13 (iii) |
| Numbers | 25.13.2 |
| Obey Instructions (Failure To) | 5.01 (w) |
| Observed driving/not up to standard | 16.21 |
| Officials-Essential | 4.03 |
| Opposite Direction to Racing | 16.15 |
| Outside assistance, Before Start, Jnr/ Rookie | 16.10 (c) (i) (d) (g) |
| Outside assistance, Before Race Starts-Mech. | 16.10 (d) |
| Outside assistance, Before Race Starts-Push | 16.10 (c) (ii) |
| Oversubscribed Classes | Chapter 18 |
| Parc Ferme area / Paddock | 17.11 |
| Passing Under Yellow Flag | 15.10 |
| Penalties - Maximum - Stewards | 6.01 |
| Penalties - Maximum - Tribunal | 6.05 |
| Penalties | Chapter 6 |
| Penalty Maximum, By Tribunal | 6.05 |
| Penalty Points | 6.02.6 |
| Penalty Time | 6.02.4 |

DRIVERS INDEX

| | |
|---|---------------------|
| Penalty, Automatic | 6.05 / 16.09 (vi) |
| Penalty, Noted On Licence | 6.02 |
| Penalty, Publication | 6.12 |
| Petrol - AKA Definition | 22.03.3(a) |
| Photo / Video etc, Proof of Incident | 4.17 (e) / 4.09 (n) |
| Pit Crew Attire | 14.12 |
| Pit Crew on Track | 17.12(f) |
| Pole Sitter | 16.09 (iii) |
| Post Event Scrutineering | 1.21 |
| Postponement / Abandonment | 1.25 |
| Practice Discretion | 16.04 |
| Practice | 16.03 |
| Pre-Heating Tyres | 23.04 |
| Protective Clothing | Chapter 14 |
| Protective Clothing/Not wearing | 14.03 / 16.07 |
| Race Line | 16.27 |
| Race Stoppage/Restart | 16.11 |
| Racing Number (Two the Same) | 25.13 (iii) |
| Radio Comms / Head sets / Officials | 17.13 |
| Radio Communication -Driver/Pits | 25.16 |
| Red Flag | 15.08 |
| Red Flag, Race Stoppage | 16.11 (a) |
| Rejoining Track | 16.18 |
| Remove Impounded Kart | 5.01 (y) |
| Remove Results | 5.01 (k) |
| Remove Seal or Mark | 5.01 (x) / 1.30.6 |
| Re-Run | 8.25 & 16.05.4 |
| Re-Scrutineering/Accident | 1.20 |
| Responsibility of Entrant/Driver/Other | 13.11 / 1.05 |
| Restarting - Karts Fitted With Clutches | 16.10 (e) |

DRIVERS INDEX

| | |
|---|-----------------------|
| Restarting Kart | 16.10 (a) / 17.10 |
| Rules, Acquaintance with | 1.04 / 05 / 06 |
| Running-in Engine (Red X on Number Plate) | 1.19 |
| Safety of Officials | 17.12 |
| Scales | 4.21 |
| Scrutineering Stickers | 1.16 |
| Scrutineering | Chapter 12 / 1.16 |
| Scrutineering-Inspection Any Time | 12.02 (a) / 12.03 |
| Sealing Nut | 1.30.9 |
| Seals-Removal | 1.30 (6) / 5.01 (x) |
| Sensor Devices / Data Loggers | 25.16 |
| Shaking Hands | 16.25 |
| Shorten a Race | 1.25.4 / 16.12 |
| Side Pods | 25.02 |
| Smoking/Welding | 17.14 |
| Speedway | Chapter 44 |
| Spirit and Intent | 1.03 |
| Stalled Kart | 16.17 |
| Start Line | 17.08 |
| Start Out of Position | 16.09.1 |
| Starter Duties of | 4.18 |
| Starting / Single File | 16.07 (e) / 16.11.d.3 |
| Starting Engines in Pits | 24.8.4 |
| Starting Kart Engines-Outgrid | 24.8.5 / 16.07 (e) |
| Starting Kart Engines-Safe Area | 24.8.6 |
| Starting | 16.09 |
| Starts / Standing | 16.09 (vii) |
| Stewards (Power Of) | 4.09 |
| Stewards Hearing | 7.19> |
| Stewards/Track Maintenance | 17.03 |

DRIVERS INDEX

| | |
|-------------------------------------|-----------------|
| Stop on Course | 16.16 |
| Street/Temporary Circuit | 17.17 |
| Supp. Regs-Standard | Chapter 11 |
| Suspension/Driver | 6.11 |
| Suspension-Consequence Of | 6.02.10 |
| System of gridding | 16.07 |
| Telemetry | 25.16 |
| Time for Complaints | 7.14 |
| Time Trials Underweight | 16.05 (e) |
| Time Trials | 16.05 (c) |
| Triming System | 16.05 |
| Track Inspector/Club | 17.01 |
| Track Inspector/State/Annual | 17.02 |
| Track Licence | 17.02 / 1.10 |
| Track Log Book | 17.03 (iii) |
| Track | Chapter 17 |
| Transponders-Driver Responsibility | 16.05 (b) |
| Tribunal Procedure | Chapter 9 |
| Trophies (distribution of) | 1.26 |
| Two Minute Board to Vacate the Grid | 16.07 (c) |
| Two Minutes to fill The Grid | 16.07 (a) |
| Tyre Marking and / or recording | 1.32.1 |
| Tyre Pooling | 23.11 |
| Tyre Treatment | 23.03 / BANNED |
| Tyres - Approved | 23.09 |
| Tyres - Choice - Wet or Dry | 1.32.2 |
| Tyres - Combination-Wet/Dry | 23.07 / 1.32.2 |
| Tyres - Damaged or Worn-Out | 1.32.4 / 1.32.5 |
| Tyres - One Set | 1.32.2 |
| Tyres - Pre-Heating | 23.04 |

DRIVERS INDEX

| | |
|--|--------------------|
| Tyres | 23 / 1.32 |
| Tyres-Chart of restricted / designated | 23.10 |
| Tyres-Number Permitted | 1.32 / 23.06 |
| Unauthorised competitions | 1.24 |
| Undersubscribed classes | 18.01 |
| Warning/Not a Penalty | 6.04 |
| Warnings-3 or more | 6.04.5 |
| Wearing Helmet After Accident | 16.20 |
| Wearing Safety Apparel | 16.20 |
| Weaving to Warm Tyres | 16.09 (ii) / 23.05 |
| Weight General | 25.19 / 1.18 |
| Weight Kart Maximum (Heavy Classes) | 25.19.2 |
| Weight, Fail To Comply | 5.01(r) |
| Weight/ No Appeal | 7.04 b, e |
| Weights in Clothing | 14.10 |
| Weights/8mm bolts | 25.19 |
| Yellow Flag (passing) | 15.10 |

2011 AKA Events Calendar

| DATE | EVENT | CLUB / TOWN | STATE |
|---------------------------------------|--|--|-------|
| February 26/27 | CIK Round 1 | Club: Ipswich Kart Club Venue: Willowbank | QLD |
| March 11/12/13 | Victorian State Championships | Host: Go Kart Club of Victoria Venue: Todd Road, Pt Melbourne | VIC |
| April 2/3 | CIK Round 2 - TBC | Host: Venue: | SA |
| April 22/23/24 | AKA 49th National Sprint Kart Championships | Club: Tiger Kart Club Venue: Cockburn Int'l Raceway | WA |
| June 10/11/12 | AKA COMMITTEE CONFERENCES | Location Sydney | NSW |
| June 17/18/19 | National Dirt Kart Championships | Location Mt Isa Club: Lagoon Park Raceway | QLD |
| June 18/19 | CIK Round 3 | Club: Go Kart Club of Victoria Venue: Todd Road, Victoria | VIC |
| July 1/2/3 | Queensland State Bitumen Championships | Club: Warwick Kart Club Venue: Sandy Creek Rd Raceway | QLD |
| July 7/8/9/10 | Northern Territory State Championships | Club: Darwin Venue: Berrimah | NT |
| July 30/31 | CIK Round 4 | Club: North Shore Kart Club Venue: Eastern Creek | NSW |
| August 19/20/21 | AKA AGM/GENERAL MEETING | Location: Cairns | QLD |
| September 1/2/3/4 | National Formula Rotax Championships | Club: Geelong Kart Club Venue: Beckley Park Corio | VIC |
| September 17/18 | CIK Round 5 | Club: Newcastle Kart Club Venue: Mt Sugarloaf | NSW |
| September 30 - October 1/2 | NSW State Championships | Club: North Shore Kart Club Venue: Eastern Creek | NSW |
| October 7/8/9 | Western Australian State Championships | Club: Albany City Kart Club Venue: Albany Highway, Albany | WA |
| November 18/19/20 | Tasmanian State Championships | Club: Launceston Kart Club Venue: Archerville Raceway | TAS |
| November 25/26/27 | South Australian Open Sprint Championships | Club: Go Kart Club of SA Venue: Monarto Kartway | SA |

2011 Calendar

January

| s | m | t | w | t | f | s |
|----|----|----|----|----|----|----|
| | | | | | | 1 |
| 2 | 3 | 4 | 5 | 6 | 7 | 8 |
| 9 | 10 | 11 | 12 | 13 | 14 | 15 |
| 16 | 17 | 18 | 19 | 20 | 21 | 22 |
| 23 | 24 | 25 | 26 | 27 | 28 | 29 |
| 30 | 31 | | | | | |

february

| s | m | t | w | t | f | s |
|----|----|----|----|----|----|----|
| | | 1 | 2 | 3 | 4 | 5 |
| 6 | 7 | 8 | 9 | 10 | 11 | 12 |
| 13 | 14 | 15 | 16 | 17 | 18 | 19 |
| 20 | 21 | 22 | 23 | 24 | 25 | 26 |
| 27 | 28 | | | | | |

march

| s | m | t | w | t | f | s |
|----|----|----|----|----|----|----|
| | | 1 | 2 | 3 | 4 | 5 |
| 6 | 7 | 8 | 9 | 10 | 11 | 12 |
| 13 | 14 | 15 | 16 | 17 | 18 | 19 |
| 20 | 21 | 22 | 23 | 24 | 25 | 26 |
| 27 | 28 | 29 | 30 | 31 | | |

april

| s | m | t | w | t | f | s |
|----|----|----|----|----|----|----|
| | | | | | 1 | 2 |
| 3 | 4 | 5 | 6 | 7 | 8 | 9 |
| 10 | 11 | 12 | 13 | 14 | 15 | 16 |
| 17 | 18 | 19 | 20 | 21 | 22 | 23 |
| 24 | 25 | 26 | 27 | 28 | 29 | 30 |

may

| s | m | t | w | t | f | s |
|----|----|----|----|----|----|----|
| 1 | 2 | 3 | 4 | 5 | 6 | 7 |
| 8 | 9 | 10 | 11 | 12 | 13 | 14 |
| 15 | 16 | 17 | 18 | 19 | 20 | 21 |
| 22 | 23 | 24 | 25 | 26 | 27 | 28 |
| 29 | 30 | 31 | | | | |

june

| s | m | t | w | t | f | s |
|----|----|----|----|----|----|----|
| | | | 1 | 2 | 3 | 4 |
| 5 | 6 | 7 | 8 | 9 | 10 | 11 |
| 12 | 13 | 14 | 15 | 16 | 17 | 18 |
| 19 | 20 | 21 | 22 | 23 | 24 | 25 |
| 26 | 27 | 28 | 29 | 30 | | |

july

| s | m | t | w | t | f | s |
|----|----|----|----|----|----|----|
| | | | | | 1 | 2 |
| 3 | 4 | 5 | 6 | 7 | 8 | 9 |
| 10 | 11 | 12 | 13 | 14 | 15 | 16 |
| 17 | 18 | 19 | 20 | 21 | 22 | 23 |
| 24 | 25 | 26 | 27 | 28 | 29 | 30 |
| 31 | | | | | | |

august

| s | m | t | w | t | f | s |
|----|----|----|----|----|----|----|
| | 1 | 2 | 3 | 4 | 5 | 6 |
| 7 | 8 | 9 | 10 | 11 | 12 | 13 |
| 14 | 15 | 16 | 17 | 18 | 19 | 20 |
| 21 | 22 | 23 | 24 | 25 | 26 | 27 |
| 28 | 29 | 30 | 31 | | | |

september

| s | m | t | w | t | f | s |
|----|----|----|----|----|----|----|
| | | | | 1 | 2 | 3 |
| 4 | 5 | 6 | 7 | 8 | 9 | 10 |
| 11 | 12 | 13 | 14 | 15 | 16 | 17 |
| 18 | 19 | 20 | 21 | 22 | 23 | 24 |
| 25 | 26 | 27 | 28 | 29 | 30 | |

october

| s | m | t | w | t | f | s |
|----|----|----|----|----|----|----|
| | | | | | | 1 |
| 2 | 3 | 4 | 5 | 6 | 7 | 8 |
| 9 | 10 | 11 | 12 | 13 | 14 | 15 |
| 16 | 17 | 18 | 19 | 20 | 21 | 22 |
| 23 | 24 | 25 | 26 | 27 | 28 | 29 |
| 30 | 31 | | | | | |

november

| s | m | t | w | t | f | s |
|----|----|----|----|----|----|----|
| | | 1 | 2 | 3 | 4 | 5 |
| 6 | 7 | 8 | 9 | 10 | 11 | 12 |
| 13 | 14 | 15 | 16 | 17 | 18 | 19 |
| 20 | 21 | 22 | 23 | 24 | 25 | 26 |
| 27 | 28 | 29 | 30 | | | |

december

| s | m | t | w | t | f | s |
|----|----|----|----|----|----|----|
| | | | | 1 | 2 | 3 |
| 4 | 5 | 6 | 7 | 8 | 9 | 10 |
| 11 | 12 | 13 | 14 | 15 | 16 | 17 |
| 18 | 19 | 20 | 21 | 22 | 23 | 24 |
| 25 | 26 | 27 | 28 | 29 | 30 | 31 |



ORGANISED BY THE AUSTRALIAN KARTING ASSOCIATION
IN ASSOCIATION WITH THE AUSTRALIAN
KARTING ASSOCIATION

50th Australian
National
Sprint Championships
6th-8th
July

2012

Darwin Karting
Association
www.dka.org.au

